



**INSTALLATION AND STARTING  
OF THE  
MICRO TECHNICAL CENTRE**

**Logo! PLC**

**U100 Control Panel**

**Radio C 200 Option (CORE432)**

**Radio C 500 Option (CORBE4RC)**

**Free Exit Option**

**(COLOGOSA / COLOGOECSA)**

**Radio AF43S Option (COAF43S)**

**Radio AF43SR Option (COAF43SR)**

Pictures are not contractual



## SOMMAIRE

<b>1.</b>	<b>PRESENTATION OF EQUIPMENTS</b> .....	<b>4</b>
<b>2.</b>	<b>PRESENTATION OF THE MICRO-TECHNICAL CENTRE</b> .....	<b>5</b>
2.1.	General presentation .....	5
2.2.	Designation of components.....	5
2.2.1	LOGO! Technical centre:.....	5
2.2.2	U100 Technical Centre:.....	6
<b>3.</b>	<b>HOW TO FIX THE CHEST?</b> .....	<b>7</b>
3.1.	How to fix the chest? .....	7
3.1.1.	Positioning:.....	7
3.1.2.	Fixing: .....	7
<b>4.</b>	<b>ELECTRICAL CONNEXIONS</b> .....	<b>8</b>
4.1.	Connexions to the bollard and loops .....	8
4.1.1.	Running the cables through the gland of the micro-technical centre:.....	8
4.2.	Connexion of the LOGO! PLC .....	8
4.3.	General wiring diagram for LOGO!.....	9
4.4.	Connexions of U100 Control Panel .....	9
4.5.	General wiring diagram for U100 micro-technical centre .....	10
<b>5.</b>	<b>AUTOMATION</b> .....	<b>11</b>
5.1.	Starting the LOGO! micro-technical centre .....	11
5.2.	Starting the U100 micro-technical centre .....	11
5.3.	Security.....	12
<b>6.</b>	<b>PNEUMATIC JUNCTIONS</b> .....	<b>13</b>
6.1.	Junction of the flexible air tube to the micro-technical centre .....	13
6.2.	Junction of the flexible air tube to the automatic retractable bollard .....	13
<b>7.</b>	<b>TESTS AND ADJUSTMENTS</b> .....	<b>14</b>
7.1.	Tests and adjustments of the automatic retractable bollard.....	14
<b>8.</b>	<b>CONTROL EQUIPMENTS AND OPTIONS</b> .....	<b>15</b>
8.1.	Operation of radio receiver – RBE4RC (LOGO! or U100) .....	15
8.2.	Operation of radio receiver - RE432 (LOGO! or U100) .....	16
8.3.	Radio frequency card for U100 control board only.....	16
8.3.1.	001AF43S .....	16
8.3.2.	001AF43SR.....	16
8.4.	"Security" option for the U100 technical centre .....	17
8.5.	"Controlled Entrance and/or Controlled Exit" for the LOGO! Micro technical centre only.....	17
8.6.	"Free Exit" option for the LOGO! Micro-technical centre only .....	17

## 1. PRESENTATION OF EQUIPMENTS

A controlled access generally consists of three or four sets of equipments interconnected (by electrical cables and pneumatic or hydraulic flexible tube):

- **The security loops** (electro-magnetic detection) are laid in the ground on each side of the bollard, providing information on the presence or absence of a vehicle nearby (two or three loops depending on the operation logic of the access : controlled entrance, controlled or free exit). They are the main element of the security system.
- **The automatic retractable bollards** are positioned on a vehicle driveway to authorize or forbid access (one or two bollards by access as a standard, other site configurations available upon request from our Technical Division).
- **Management system:**
  - § Access controller **with technical centre built-in**,
  - § or access controller such as a *City* controller **separated from the technical centre** housed in a cabinet.

The management system receives instructions from the user (by beeper, contact free card, push button, etc), runs the access operation mode (it usually comprises a programmable PLC or a simple control panel) and supplies power necessary for the actuation of bollards (pneumatic compressor or hydraulic group). Power supplied is 230 VAC (16 A with earth).

*To install security loops and automatic retractable bollards, please refer to the respective manuals.*

The positioning of security loops is an important condition for the proper operability of the access. We therefore **highly recommend to first determine the position of loops in priority**, then the position of bollards and management system.

## 2. PRESENTATION OF THE MICRO-TECHNICAL CENTRE

### 2.1. General presentation

The body of the Technical Centre is a sheet steel chest measuring 600 x 400 x 250 mm. It is tained beige (RAL 7015), the complete chest (with all components built in) weighs about 23 kg. Class II insulation and IP45 protection guaranteed.

The whole set may run 1 or 2 bollards by access site depending the type of compressor used. The access is programmable as controlled entrance, or as controlled exit, or as controlled entrance and exit and free exit for micro-technical centres with Logo! PLC.

### 2.2. Designation of components

#### 2.2.1 LOGO! Technical centre:

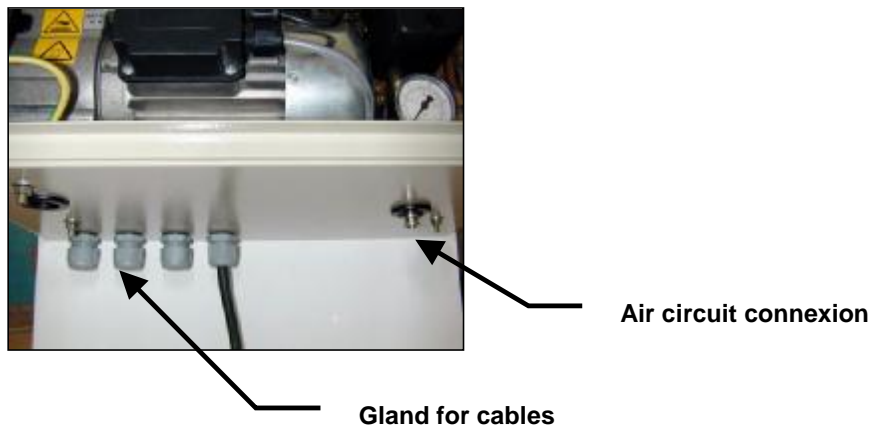
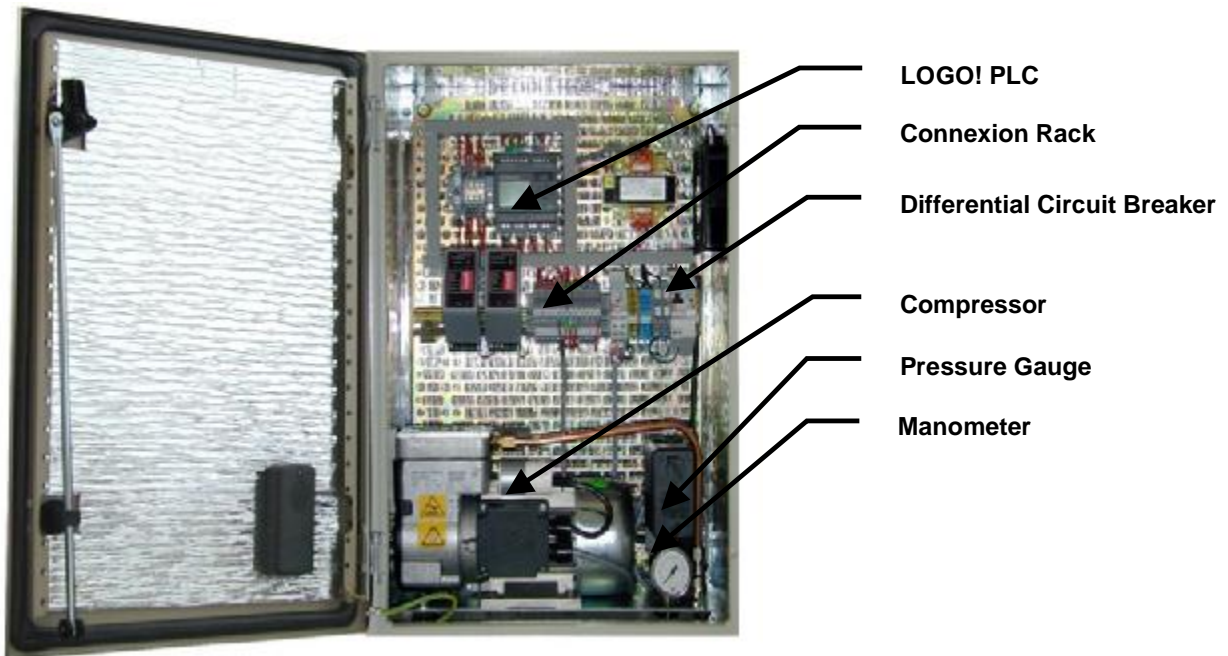

2.2.2. U100 Technical Centre:

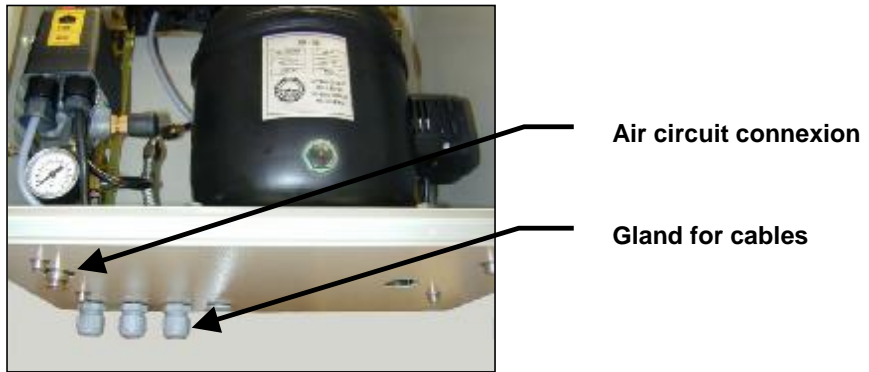
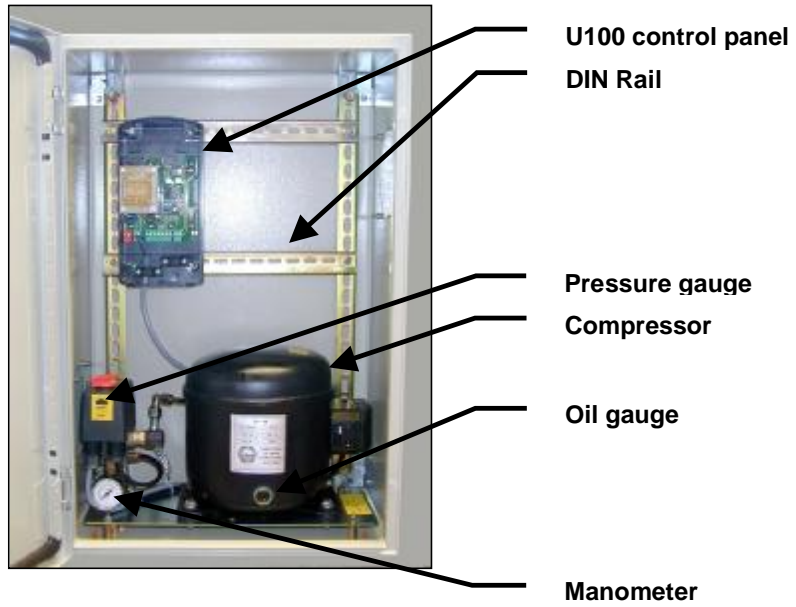

### 3. HOW TO FIX THE CHEST?

#### 3.1. How to fix the chest?

##### 3.1.1. Positioning:

The micro-technical centre must be placed as close as possible to the access to be operated, inside or outside (garage, technical premises) The level of noise is fairly weak (< 50 dB) but still, its installation inside an office or habitation must be avoided.

Thermal insulation built in. Temperature must not exceed 45°C inside the chest: make sure all side openings as well as the lower air vent are not sealed.

The door should be locked and the whole installation out of children's reach..

**The distance between the security loops and the micro-technical centre must imperatively be less than 50 metres.**

Reminder: standard loops are delivered with loop ends 25 m long or 50 m long (depending on the reference of the loop ordered).

##### 3.1.2. Fixing:

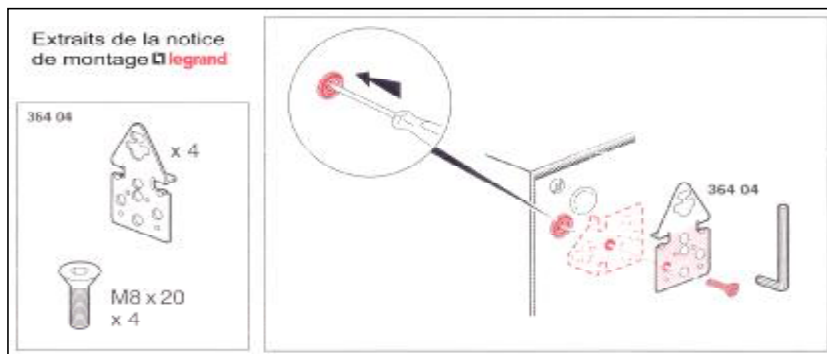

Wall-mount with 4 clamps screwed onto the chest, either lengthways or heightways (but the chest should be fixed vertically in any way). The clamps are screwed inside the wall with concrete pegs (or similar), not supplied.



## 4. ELECTRICAL CONNEXIONS

### 4.1. Connexions to the bollard and loops

4.1.1. Running the cables through the gland of the micro-technical centre:

Security loop ends (twisted pairs) must not be laid near other conductors, but vertically on the right hand side of the City 5 cabinet. Adhesive embedding bases (not supplied) are to be used as holders for fixing rings.

### 4.2. Connexion of the LOGO! PLC

**ALL CONNEXIONS MUST BE MADE WITH POWER TURNED OFF!**

- § 2 conductors for solenoid valve (between markers 9 and 20 on connexion rack)
- § 2 conductors for lower limit switch (between marker 9 and 59), and upper limit switch (60) as an option.
- § Both conductors of each loop end are twisted all the way to the connexion rack.
- § Remove the circuit breaker from its rail to connect all 3 conductors (220 VAC + Earth)



**Advice** : crimp a wire connector to the end of each conductor used (in case it is flexible multi-strand wire). Wind sticky tape up the end of each cable sheath (right where the conductors stick out).

#### 1) Connect cable 5 x 1,5 mm<sup>2</sup> from the bollard

The 5 conductors have been marked while the automatic retractable bollard was being installed. One of them (ULS / upper limit switch) is only used with this option, between markers 9 and 60.

**Our cables have no polarity: both conductors may completely be inverted.**

**Tighten the screws of the connexion rack.**

#### 2) Connect the end of Loop #1

Make sure to keep the twist of both conductors all the way to the connexion rack (1 twist at least every 10 cm) Insert both conductor ends between markers 7 and 8 on the detector support and tighten the screws.

#### 3) Connect the end of Loop #2

Make sure to keep the twist of both conductors all the way to the connexion rack (1 twist at least every 10 cm) Insert both conductor ends between markers 3 and 5 on the detector support and tighten the screws.

#### 4) **POWER OFF:** set power supply onto the connexion rack of the circuit breaker

Remove the circuit breaker by turning it down from its rail so as to access its connexion rack. Insert the ends of the 3 conductors (earth, phased, neutral) and tighten the screws. Reset the circuit breaker back onto its rail.

### 4.3. General wiring diagram for LOGO!

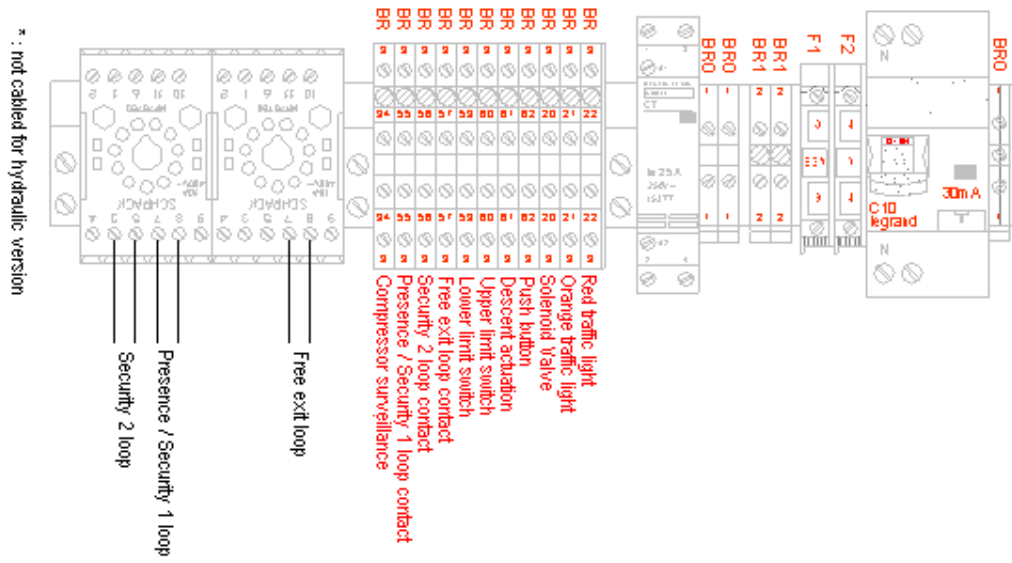

### 4.4. Connexions of U100 Control Panel

**ALL CONNEXIONS MUST BE MADE WITH POWER TURNED OFF!**

- § 2 conductors for solenoid valve (between markers EV1 and EV2 on draw-out connector)
- § 3 conductors (230 VAC + earth) to connect on markers L and N. Earth must be connected to the compressor's earth.



4.5. General wiring diagram for U100 micro-technical centre

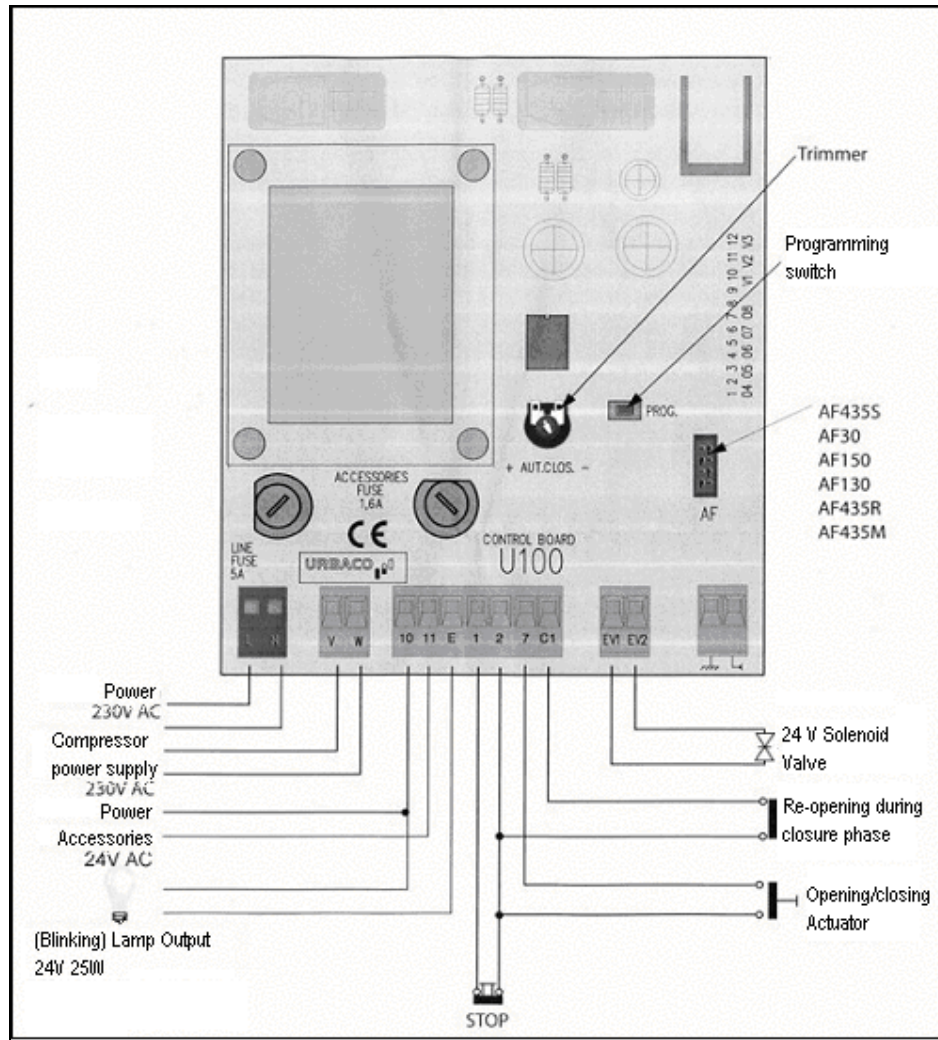

## 5. AUTOMATION

### 5.1. Starting the LOGO! micro-technical centre

All the components of the MTC were pre-set at the factory. Starting will be done by using default options (see LOGO! PLC manual).

- 1 – Turn the compressor switch off (OFF, on the left).
- 2 – Switch differential circuit breaker on (push upwards).
- 3 – Wait for at least 5 to 10 seconds until PLC and detectors are initialized.

Display will show:

An hourglass ⌚ for about 7 seconds, then:

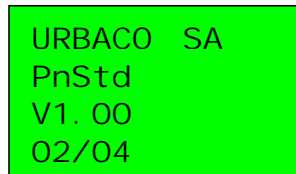

```
URBACO SA
PnStd
V1. 00
02/04
```

Showing the programme name, its version and date of creation.

- 4 – CHECK THAT NO VEHICLE OR METAL OBJECT IS ON THE LOOPS and push on the "RAZ" reset key of each detector to initialize their memory on 'free' (in other words, without any vehicle being detected).

NOTE: The procedure of loop detector re-initialization described in §4 here above has to be completed each time the loop sensibility level is modified and, generally, each time a malfunction is suspected. IT IS OF PARAMOUNT IMPORTANCE THAT NO VEHICLE is placed over the loops when the "RAZ" reset key is engaged.

### 5.2. Starting the U100 micro-technical centre

The U100 control board does not need any preliminary factory setting. It will be started by using default options (see U100 control board manual).

- 1 – Turn the compressor switch off (OFF, on the left).
- 2 – Turn the U100 MTC on.

### 5.3. Security

**Bollard security** is ensured by the surveillance of electro-magnetic loops before and while the bollard moves upward, so as to limit the risk of an impact with a vehicle. When a metallic presence is detected on one of the loops:

- if the bollard is retracted, it remains so;
- if the bollard is moving upwards, it moves back down.

Watch out for the system's inertia which does not permits the inversion of the movement for a lapse of time short enough to avoid any contact between the vehicle and the bollard if the vehicle does not stop.

**Note: Do not leave any vehicle parked or at a standstill on the access when the bollard is retracted.**

After 15 or 20 minutes parking over the loop, the system might « forget » that a vehicle was detected 15 or 20 minutes earlier, in which case, the bollard will try to move upwards again. If it is prevented to do so, it will retract and after 3 attempts, the system will be on default.

## 6. PNEUMATIC JUNCTIONS

### 6.1. Junction of the flexible air tube to the micro-technical centre

Cut the flexible tube 1 cm from its end (with a cutter for instance). The cutting must be neat and perpendicular. Joint the end into the quick coupling at the base of the MTC chest (item #6 on the picture 4.1.1 page 8).

WATCH OUT! **DO NOT BEND** THE FLEXIBLE AIR TUBE .

**Note:** We strongly recommend not to shorten the flexible air tube because it will be used as an air reserve for the compressor.

### 6.2. Junction of the flexible air tube to the automatic retractable bollard

Depending on cases, the automatic retractable bollard has already been installed or the installation is done at the same time as the City 5 cabinet (see manual for the installation and connexions of automatic retractable bollards).

For this junction, the bollard cover must be removed.

Unplug the flexible tube from the bollard side. Start the compressor (switch it on « ON », right hand side) to clean the inside of the tube (10 seconds). Then stop the compressor.

(Cf. photograph next page for #1 and #5)

Cut the flexible tube (5) 1 cm from its end (with a cutter for instance).The cutting must be neat and perpendicular.

Joint the flexible to the solenoid valve with the connector supplied (quick coupling (1) without tool or crimping). Push the flexible (5) back into the sheath.

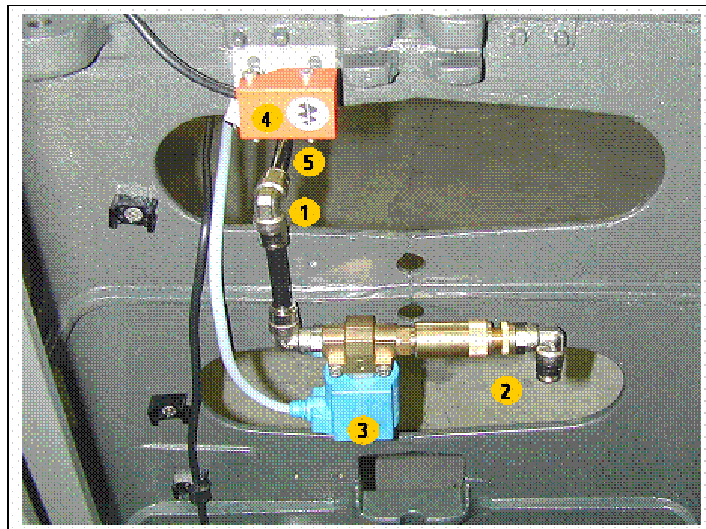

(1) quick coupling - (2) air flow regulator - (3) solenoid valve  
(4) upper limit switch sensor (optional) - (5) flexible air tube towards compressor

## 7. TESTS AND ADJUSTMENTS

### 7.1. Tests and adjustments of the automatic retractable bollard

- 1) Check that the emergency stop button is not engaged.
- 2) Switch the compressor on (« ON »). The bollard must rise.
- 3) Place a vehicle on a security loop (if they have been planned in the system and programmed as actuator by presence detection) and actuate with a radio transmitter, valid contact free card, code... (See the user's guide to the control actuator installed).  
The bollard must move down. When it is fully retracted, the red traffic light turns off and the orange starts blinking (or the green light turns on, depending on option chosen and if traffic lights have been installed).
- 4) Remove the vehicle away from security loops or actuate again with controller. The orange (or green) light turns off, the red light starts blinking and the bollard moves upwards. When the bollard is completely risen, the red light remains on (steady).
- 5) Set the bollard rising speed with the wheel (2) (air flow regulator) located on the solenoid valve output. Use the on/off switch of the compressor for the different tests. Time set for the bollard rise must be set on 3 to 5 seconds (less than that is not recommended).

If the access comprises several bollards, set identical rise times for all bollards.

Once testing and adjustments have been made, re-surface the ground if not done yet ((see manual for the installation and connexions of automatic retractable bollards), and close the bollard cover. Make sure to respect traffic flow direction.

## 8. CONTROL EQUIPMENTS AND OPTIONS

### 8.1. Operation of radio receiver – RBE4RC (LOGO! or U100)

**Rolling Code Receiver** with four channels, frequency AM 433.92 MHz, to be mounted inside the City 5 cabinet. It may be coupled with CAME beepers, type **ATOMO**, up to 500 units maximum. ABS box with IP54 protection level. It has its own internal display unit which, with the Rolling Code technology, helps memorize quickly the beepers ( max. 500) and maintain a problem-free installation (cancellation/ re-connexion, adjunction or modification). It also includes a memory card (Memory Roll) to do a back up copy of all beepers memorized.

**Note: All programming and management operations of the installation may also be achieved from a P.C. with the corresponding software.**

Power supply for card: 24V a/c.

Output operation:

- OUT1 in mono-stable or bi-stable mode
- OUT2 in mono-stable mode with adjustable temporization between 1 and 300 seconds
- OUT3 e 4 in en normal mono-stable mode

**Note:**

- The receiver must always have an aerial.
- Do not install several receivers at a distance inferior to 4/5 m one from the other to prevent anomalies or malfunctions.
- **The aerial should be installed as high up as possible from the ground and away from metallic structures and/or reinforced concrete.**

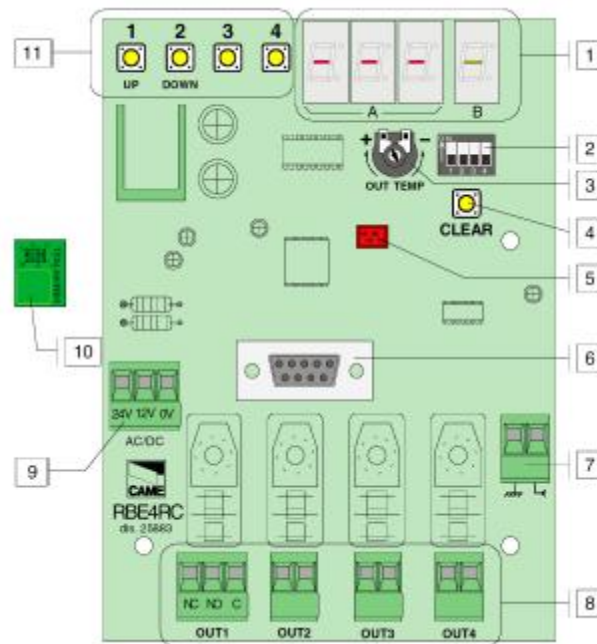

1. Programming screen
2. 4-way micro-switch
3. OUT2 relay adjustment equalizer
4. Zeroing key
5. Memory Roll connection card
6. RS232 connector for P.C. junction
7. Terminal board for aerial connexion.
8. Terminal board for connexion of control devices
9. Terminal board for power supply in 12/24V AC/DC.
10. Memory Roll card
11. Programming keys

**8.2. Operation of radio receiver - RE432 (LOGO! or U100)**

Universal 2-channel receiver with AM 433.92 MHz frequency, placed inside the MTC, in its housing with IP54 protection level.

It works with all CAME beepers, type TOP/TAM at 433.92 MHz.

Both channels work normally in « mono-stable » mode, but the « bi-stable » mode (switch) may also be selected on the 2<sup>nd</sup> channel. It is powered in 24 V A/C.

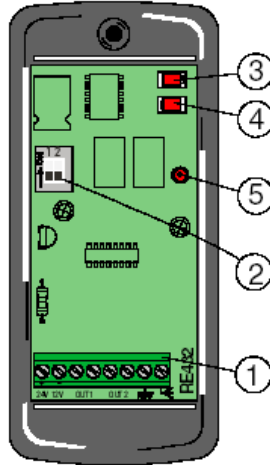

- 1 Terminal board
- 2 Dip-switch
- 3 Code memory key 1<sup>st</sup> channel
- 4 Code memory key 2<sup>nd</sup> channel
- 5 LED light (on/off)

Programming – Remote control

- A) Encoding the beeper;
  - B) Power for receiver;
  - C) Press on a memory key (the warning LED light starts blinking) and register code by pressing on a beeper key (the LED light remains on to inform that memorization has been completed).
- Same procedure for the other memorization key.  
 Note: repeat this sequence later to change code when necessary.

**8.3. Radio frequency card for U100 control board only**

8.3.1. 001AF43S



This draw-in/draw-out radio printed board for the U100 control panel is operational on a 433.92MHz frequency. It works with beepers of the TOP and TAM type. Its capacity for beepers is unlimited.

8.3.2. 001AF43SR



This draw-in/draw-out radio printed board for the U100 control panel is operational on a 433.92MHz frequency and includes an EEPROM memory. It works with beepers of the TOP and TAM type. It can memorize up to 128 different codes.

**8.4. "Security" option for the U100 technical centre**

The "Security" option of the U100 consists of a one-channel or two-channel sensor/detector with backed-up memory. It is connected to the detection loop(s) laid around or upstream/downstream of the bollard. This sensor/detector is a guarantee of security when the bollard rises if a vehicle happens to be nearby.

This option may be envisaged with photoelectric cell barriers.

**8.5. "Controlled Entrance and/or Controlled Exit" for the LOGO! Micro technical centre only.**

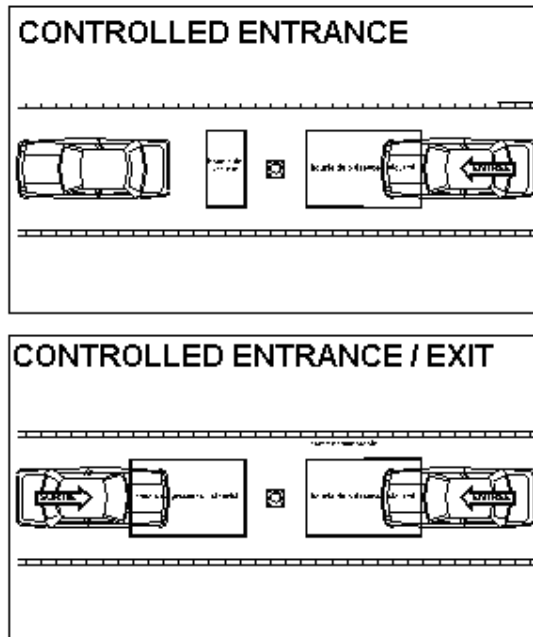

The "Controlled Entrance and/or Controlled Exit" option for the LOGO! Micro technical centre consists of a two-channel sensor/detector with back-up memory. It is connected to the detection loop(s) laid around or upstream/downstream of the bollard. This sensor/detector is a guarantee of security when the bollard rises if a vehicle happens to be nearby. It can also control the descent actuation of the bollard. In case of a controlled entrance **or** exit, the bollard will retract only for one traffic direction of the access location. In case of a controlled entrance **and** controlled exit, the bollard will retract in both traffic directions configured for the access location.

**8.6. "Free Exit" option for the LOGO! Micro-technical centre only**

The « Free Exit » option designed for the LOGO! micro-technical centre consists of a one-channel sensor/detector with back-up memory. Connected to the detection loop, it can actuate the descent of the bollard if a vehicle happens to be detected on the free exit and security loops for a lapse of time entered and programmed in the PLC.

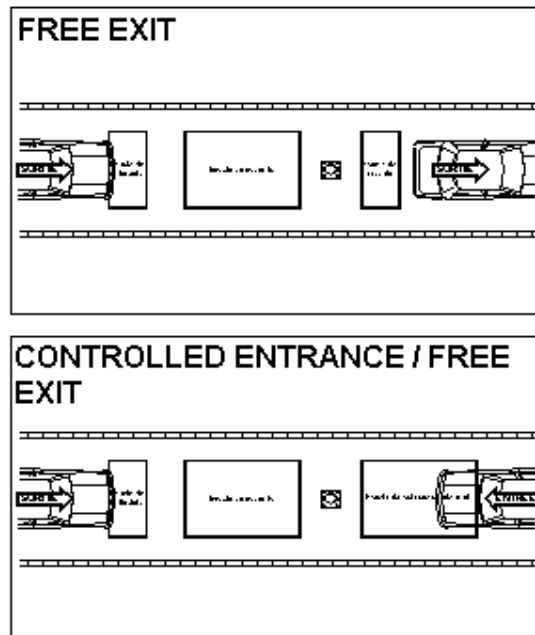



## **TRAINING SESSIONS**

URBACO as a recognized training organization can organise technical training sessions for the whole range of products manufactured:

- Range of Bollards (fixed, removable and automatic) and Site Furnishings.
- Range of Automation and Access Control Systems.
- Range of Centralized technical management and associated software.

Sessions are organized for a one- to two-day period, 3 languages to choose from.  
For further details regarding these sessions, revert to the International Sales Department of URBACO.

## **MAINTENANCE CONTRACT:**

URBACO offers maintenance contracts adapted for your installations and to your expectations:

- Preventive maintenance contracts.
- Curative maintenance contracts (with price quotation).
- Other: night-time intervention, duties ....

For further details regarding these sessions, revert to the International Sales Department of URBACO.

## **INTERNATIONAL SALES DEPARTMENT:**

Open Monday through Friday  
From 08:00 to 12:30 and 14:00 to 18:00 on:

**+33 490 480 800**

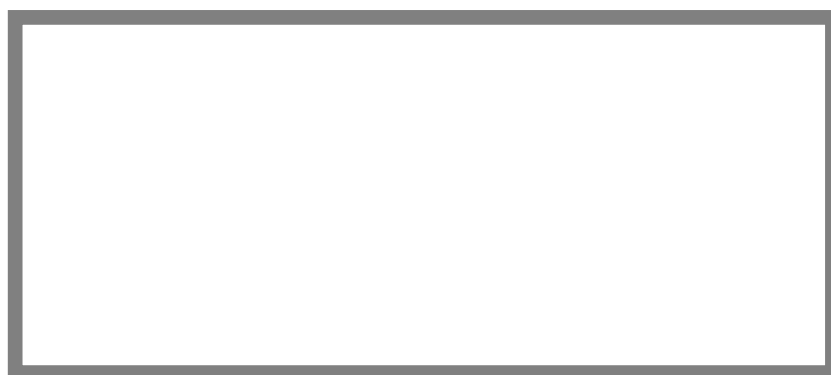

URBACO S.A. - Z.A. du Couquiou 84320 ENTRAIGUES - FRANCE  
Tel export : +33 490 480 800  
Fax : +33 490 480  
E.mail : [export@urbaco.fr](mailto:export@urbaco.fr)