



Lighting and automation command module

Installation

GB





Summary

Presentation	125
Description	128
● Description of the module.....	128
● Description of terminals.....	129
Installation precautions.....	130
Selection of options	132
Powering the module.....	133
Radio recognition	134
● Radio recognition of a lighting control.....	134
● Radio recognition of an automatic device control	135
● Radio recognition of an automatic lighting control	136
● Radio recognition suppression	138
Radio range test	139
Locating the module	140
Method of lighting control choice	142
Wiring.....	144
What to do if...?	146

Symbols:



Ground wire



Electric shock risks





The module has two output relays. It is possible to use either, or both, of the relays to achieve two distinct functions.

The module can command:

- A lighting or automatic device, on relay 1
- An automatic device solely, on relay 2.

The module receives commands via the handset's lighting command key and/or automatic device/garage door command key. The handset displays the state of the lighting (lit or off) and of the automatic devices controlled (open or closed).

The control of the lighting is possible from the 'lighting'  key of the Doorphone's handset (simple switched lighting or via remote control unit) and can be either ON/OFF or timed (adjustable length).

The lighting can also automatically follow the door  or gate access control  buttons of the Doorphone (this function is also possible with other means of command, see explanation on page 136).

Note that in this last case a photocell (LDR) can be adjusted to allow night time operation only.

The following diagram represents the different options for configuring a system to handle lighting and automatic devices.

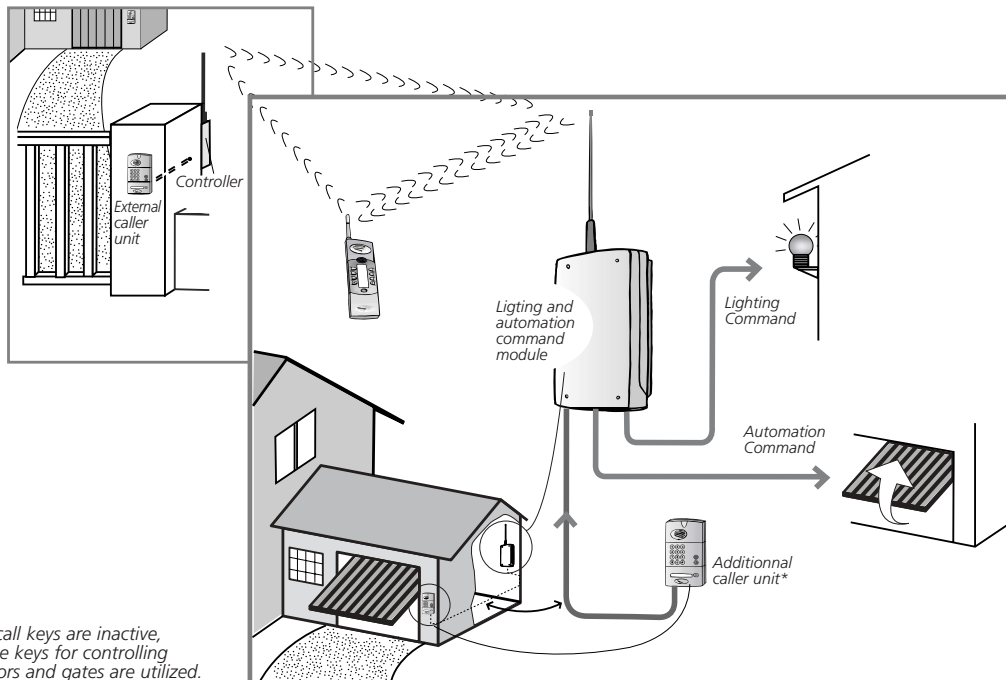

** The call keys are inactive, only the keys for controlling the doors and gates are utilized.*



Here are three common application examples!

- ▶ **Application n° 1** : the customer wishes to control a light and a garage door from the handset of a Doorphone.
Relay 1 will be used for the control of a light and relay 2 (solely assigned for the control of an automatic device) will be used to trigger the motorized garage door.

- ▶ **Application n° 2** : The customer wishes to control two garage doors independently of each other.
Relay 1 will be used to control the first motorised garage door and relay 2 (solely assigned to this type of command) will be used to control the second motorized garage door.
Note that in order to control an additional light it is necessary to acquire a second module!

- ▶ **Application n° 3** : The customer wishes to automatically switch on lighting when opening the motorized gate from the Doorphone handset. The customer also wishes to control a motorized garage door..
Relay 1 will be used to control the automatic lighting and relay 2 (solely assigned for the control of an automatic device) will be used to trigger the garage door.
Other applications are feasible, contact technical support for further details (see phone numbers on the guarantee form).





Use the
◀ and ▶
buttons.

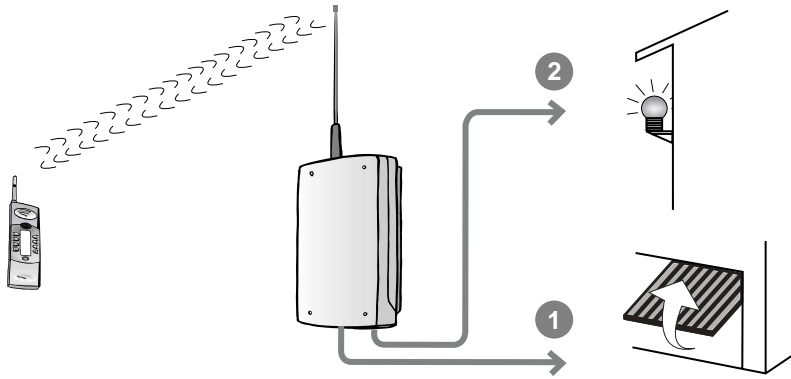

Use the two
◀ ▶ buttons.

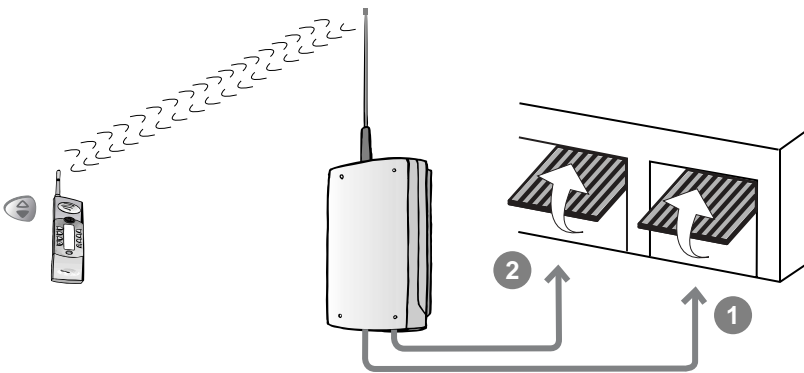

Use the
◀ ▶ and
⏻ buttons.

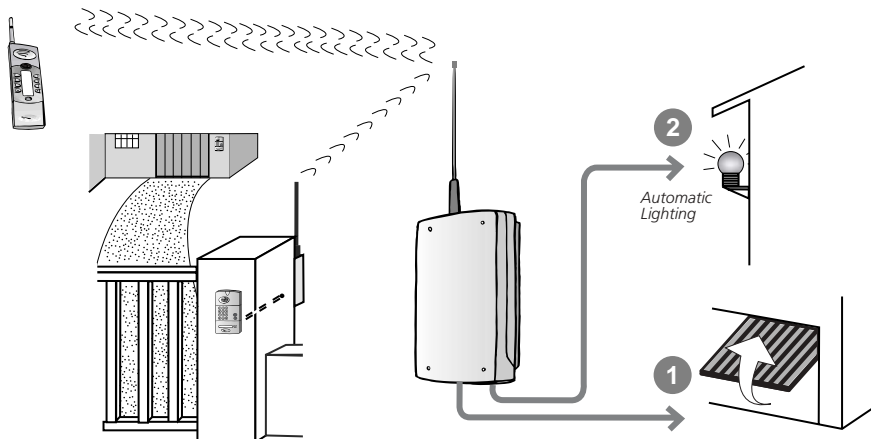

GB



Description

● Description of Module

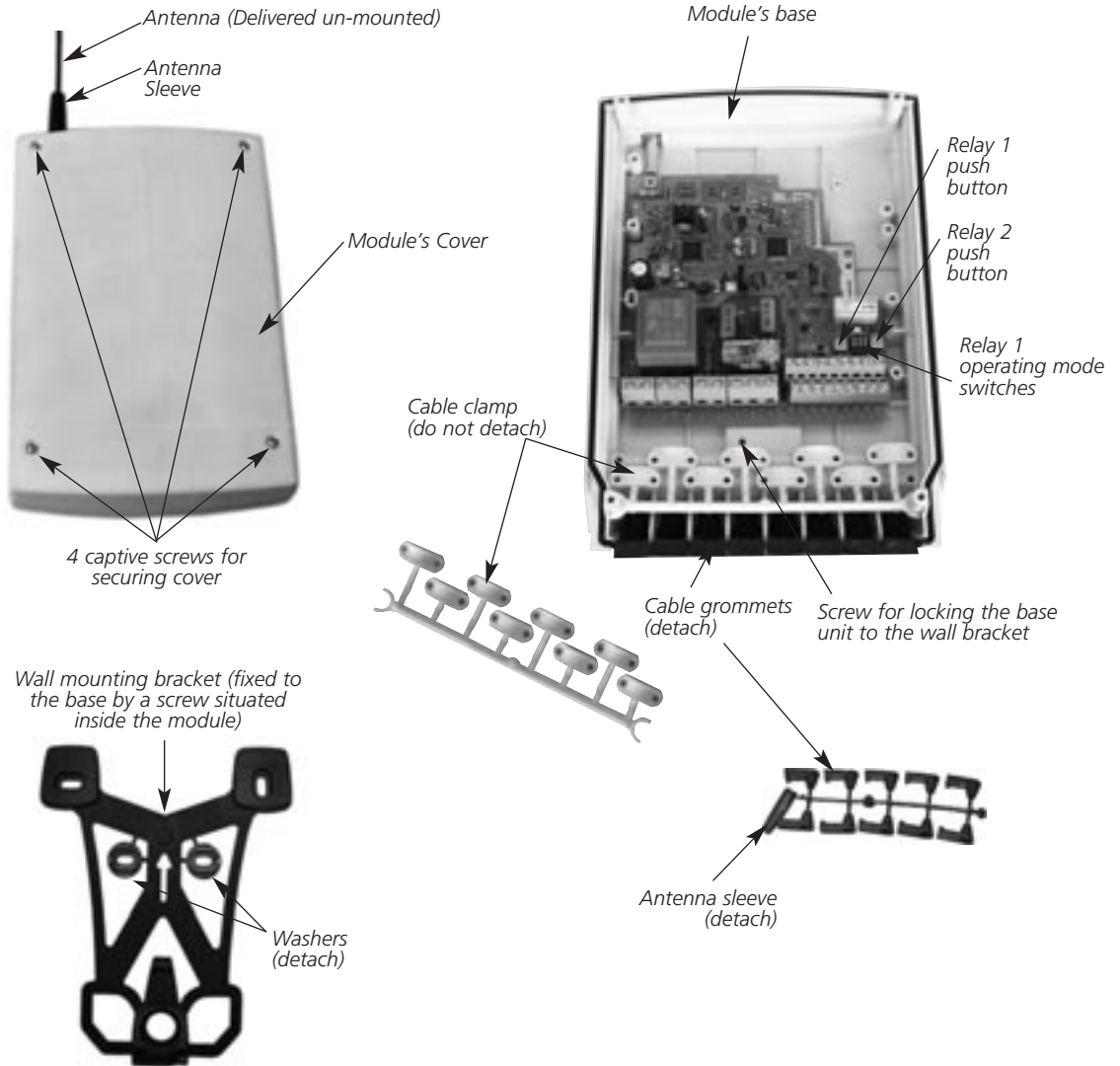

The antenna sleeve, grommets, cable clamps and screws are supplied in an accessory bag.



● Description of Terminals

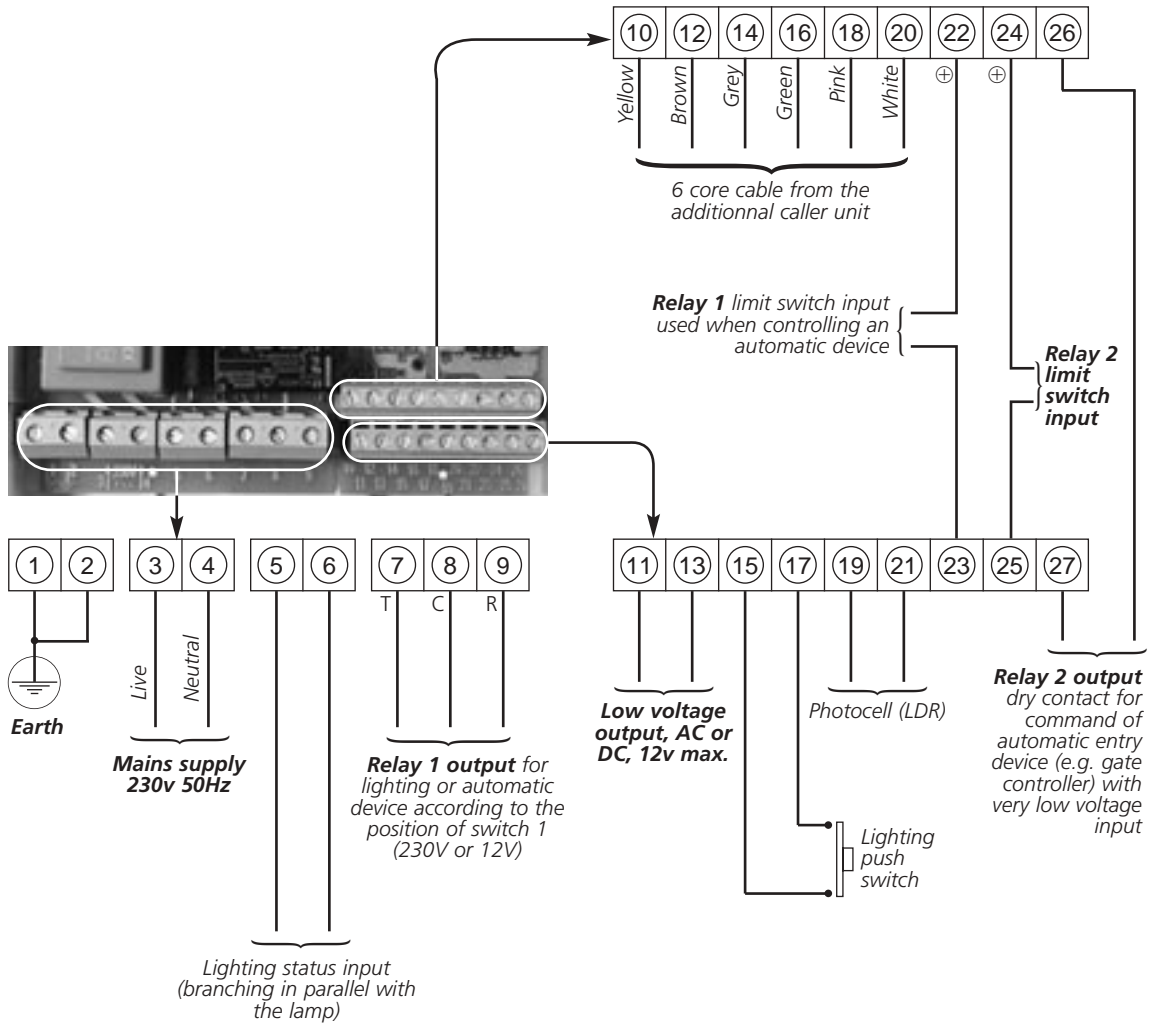



Installation Precautions

ATTENTION: BEFORE ANY WORK IS DONE SWITCH OFF THE MAINS POWER! THE INSTALLATION MUST BE IN LINE WITH ALL CURRENT LEGISLATIVE REQUIREMENTS. ALL WORK MUST BE CARRIED OUT BY A PERSON WHO IS FULLY QUALIFIED TO DO SO.

The module must be protected by a cut-out (fuse or thermal cut-out) and by a differential cut-out!

- ▶ The module can be installed either indoors or outdoors (pillars, walls, loft, garage...).
- ▶ Avoid positioning the product close to sources of electromagnetic interference.
- ▶ Avoid situating the antenna of the module next to a cable run, especially the power supply cable of the module or any external cables (see diagrams 1 and 2).
- ▶ Avoid situating the antenna along metallic pipe-work (see. diagram 3).
Avoid close proximity to large metallic items, concrete walls, metallic garage door... (keep a minimum distance of 30 cm).

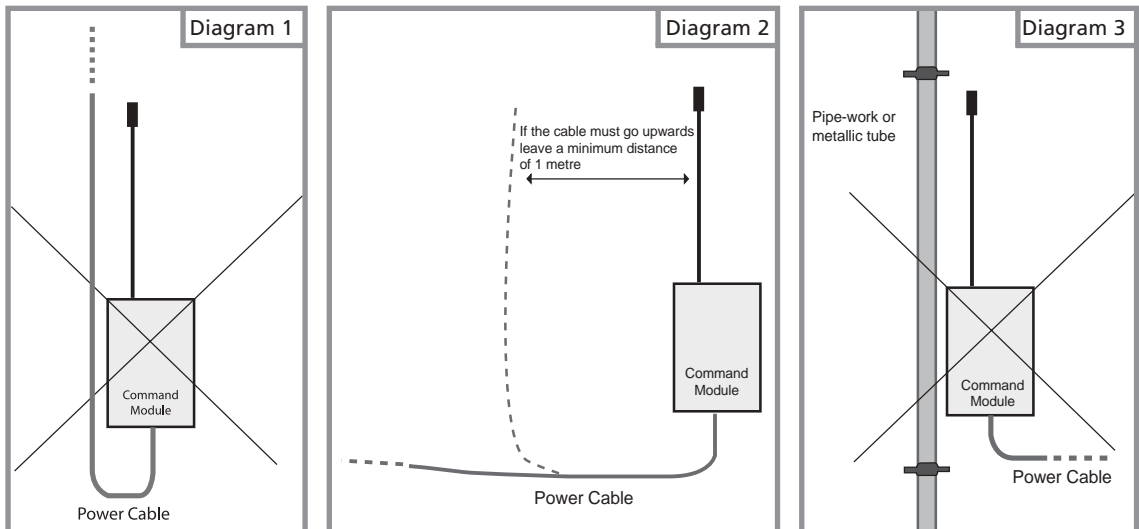

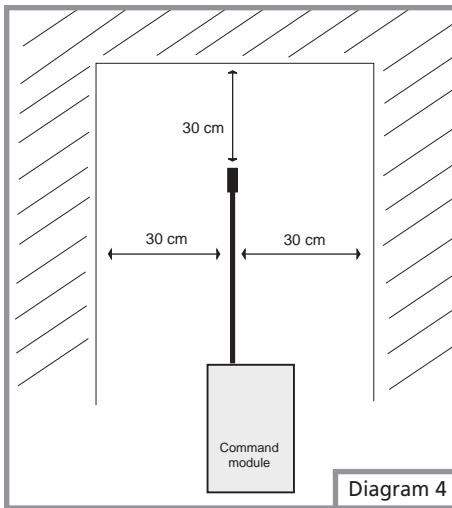

- ▶ The module should be kept at least 2m from the controller of the doorphone.
- ▶ The module should be kept at least 2m from the handset.
- ▶ In order to facilitate the fixing of the base, find a smooth surface on which to fix the wall bracket.
- ▶ Ensure a free space of 30cm around the antenna. The module must be installed with its antenna upwards (see. diagram 4).

Important:

- Carry out a test of radio range before permanently fixing your module.
- **Dynapass**® Technology multifrequency ultra-reliable radio, up to 400m range in free field (1), (will vary according to environmental conditions and installation) (2).
- High fidelity audio.

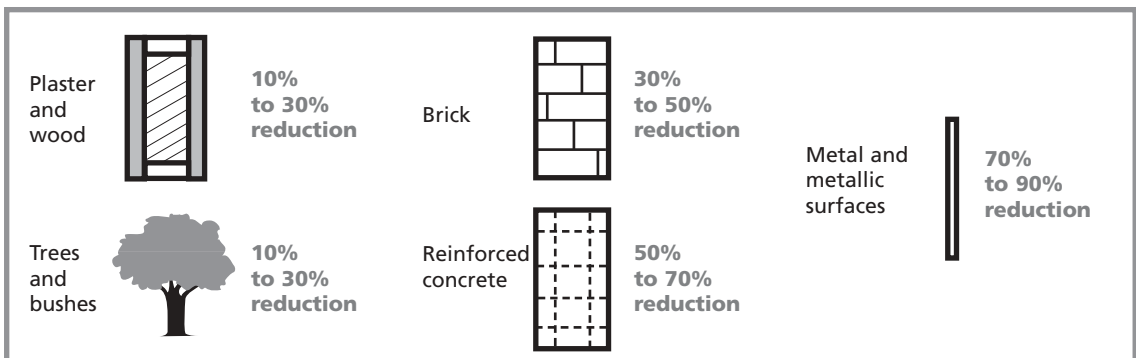

- (1) The free field range corresponds to the theoretical maximum distance separating the controller and the handset, in the absence of all obstacles (e.g: walls, metal fencing, vegetation, electromagnetic disruption) which by nature would reduce the reach.
- (2) To optimise the performance of the DoorPhone, adhere to the installation guidelines contained within and carry out a pre-test.



Selection of Options

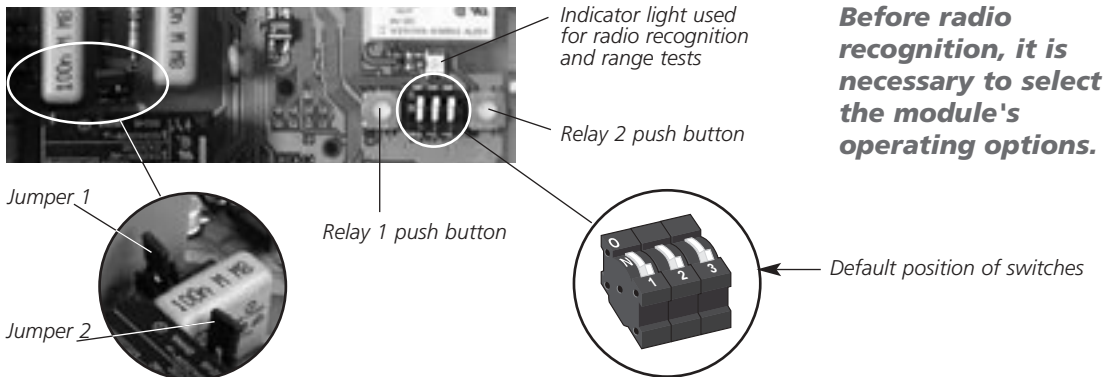

Before radio recognition, it is necessary to select the module's operating options.

► Jumper selections

Jumper 1	Fitted	For powering a 220V AC lamp
	Removed	For powering a 12V AC or 12V DC lamp
Jumper 2	Fitted	Simple switch command
	Removed	Remote control unit type command or lighting of an energy saving lamp

The choice between the ON/OFF method and the timer method (with choice of duration) for the lighting, is dealt with later (see. p. 142).

► Switch selections

Switch 1		Relay 1 controls and automatic device (1)
		Relay 1 controls lighting
Switch 2		Lighting control is via a simple switch
		Lighting control is via remote control
Switch 3		Automatic lighting following the entry of a car or pedestrian via the doorphone keypad (2)
		No automatic lighting following the entry of a car or pedestrian via the doorphone keypad

(1) in this configuration, the position of switches 2 and 3 are not taken into account..

(2) other means of control are permissible, see. p. 136.

Powering the Module

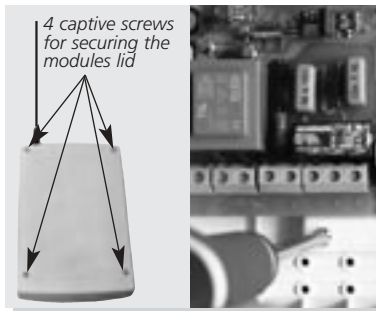

1 Open the module by unscrewing the 4 lid screws and remove the fixing bracket after having unscrewed the locking screw situated inside the module. Keep the fixing bracket as it will be used for mounting the module.

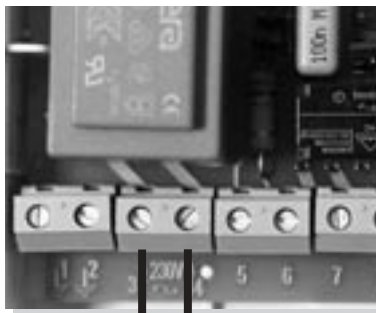

Live Neutral
mains 230 V (50 Hz)

2 For mains supply 230V AC: Connect the live to terminal 3 and the neutral to terminal 4.

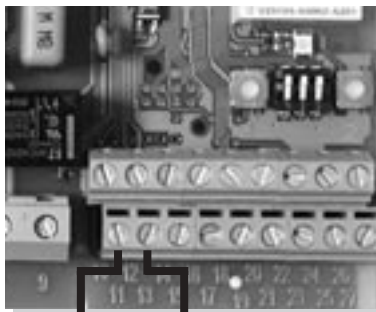

12 V (AC ou DC)

2 alternative
For low voltage: connect 12V AC or 12V DC to terminals 11 and 13.



Radio Recognition

Radio recognition allows each handset to identify the module(s) that it is going to command. Radio recognition must be carried out with each of the handsets that will command the module.

Bring the handset close to the module!



● Radio recognition of a lighting control

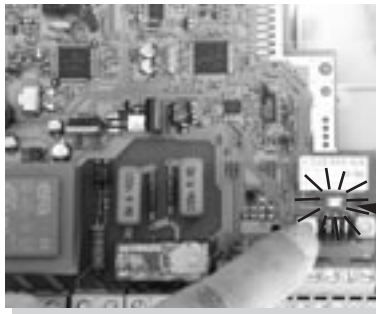

Remember: Only relay 1 can be used for lighting control



1 Press the pushbutton switch of the relay 1 until the LED blinks. Let go.



2 While the LED blinks, press the  key on the handset until the handset gives out a resonant BEEP. The radio recognition is successful. Trigger a test control of the lighting (the  key of the handset facilitates this), the  indicator blinks (relay 1 contacts are closed).

Contrary to the other command keys, the fact that radio recognition was achieved with the  key is not sufficient to make the  indicator appear. To achieve this it is also necessary to connect terminals 5 and 6 (see. page 145).

If the resonant BEEP is not generated and if the  indicator doesn't blink at the time of a lighting control, the radio recognition failed.

Restart the procedure from the beginning while taking care to move the handset less than 2m away.

If the radio recognition fails again, redo the procedure and push the  key again as soon as the handset gives out a resonant BEEP.



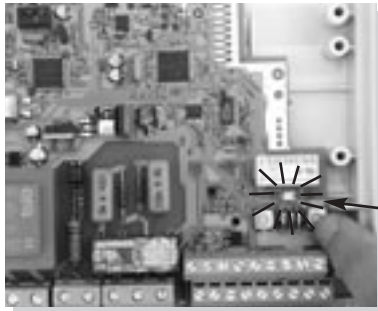

● Radio recognition of an automatic device control

Let's take the example of relay 2 assigned to control an automatic device.



1 Press relay 2 pushbutton switch until the LED blinks. Let go.

2 While the LED blinks, press the  key (example of an automatic garage door controller) on the handset until the handset gives out a resonant BEEP and displays  or .



The procedure would be identical for relay 1 assigned to the control of an automatic device.

If the resonant BEEP is not generated and if the  or  indicator doesn't blink at the time of the  key press, it means that the radio recognition failed.











Restart the procedure from the beginning while taking care to move the handset less than 2m away.

If the radio recognition fails again, redo the procedure and push the  key again as soon as the handset gives out a resonant BEEP.

The radio recognition of a handset doesn't stop the modules learning procedure.

Thus, at the same time a second handset can be learned, provided that it is the same recognition function (either lighting or garage).

In factory default, the control of the automatic device is set to 2,5s (Relay 1 and relay 2). If this duration needs adjusting in consideration of the garage door motor connected, it is possible to reduce it with the following procedure:

- press and hold (> 5secs) the corresponding  key (garage door 1 / garage door 2), the handset gives out a resonant BEEP and the corresponding  indicator blinks, the other indicators disappear,
- while the  indicator blinks, briefly push the  key again, the  indicator appears,
- press the  key to adjust down to 2secs, the  indicator becomes . The use of the  and  keys, allows adjustment from a minimum of 0.5secs to a maximum of 2.5secs (each bar corresponds to 0.5secs).



● Radio recognition of automatic lighting control

The radio recognition takes place between the controller of the Doorphone and the module. Before beginning the procedure, verify that **switch 1 is in the OFF position and that switch 3 in position ONE**. Remove the lid of the Doorphone's controller.

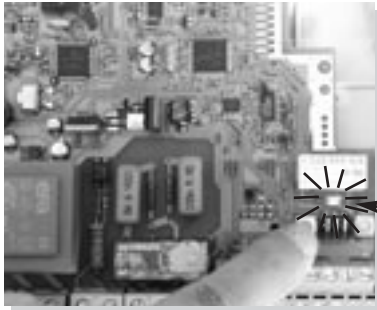

1 Press relay 1 pushbutton in the module until the LED blinks. Let go.

Carry out steps 2 and 3 at the controller/call unit, within 12secs of completing step 1.



2 While the LED blinks, push the controllers push button.





3 Push a call button of the caller unit. The caller unit gives out a series of BEEPs and the LED of the module extinguishes. The radio recognition is successful.

If the modules LED doesn't extinguish, restart the procedure from the beginning while ensuring a distance of less than 2m between the controller and the module and verify that all options are correctly selected.

Depending upon the date of manufacture of the Doorphone's controller, means of command for activating the automatic lighting control differ.



Therefore the controller must be identified! On the label that is on the back of the controller, check whether there is an  icon.

- No  icon means that control of automatic lighting is solely possible from the Doorphones caller unit, also good for the control of locks (pedestrian access) and control of gate opening (vehicle access).

- Icon  present means that control of automatic lighting is possible by any means of command used, also good for the control of locks (pedestrian access) and control of gate opening (vehicle access).



● Deletion of radio recognition

Attention: this procedure is solely necessary if the control of lighting or automatic device must be suppressed. The fact that the  key may be deleted doesn't mean the  key has been deleted.

Therefore it should be noted that this procedure must be carried out for each handset key to be deleted.

There are two methods of suppression depending upon the handset

▶ If the  icon is not present on the label on the back of the handset





1. Press the key of the function to deactivate and to keep holding the key until the indicator of the function concerned blinks on the display. All other indicators disappear. Let go. The indicator of the function concerned continues to blink. Don't press any keys but wait until the indicator of the function stops blinking.



Now when pressing the concerned command key, the indicator doesn't appear on the handsets screen and no beep generated.

▶ If the  icon is present on the label on the back of the handset



1 Press the  key (example of an automatic garage door device) and keep pressing until the indicator of the function concerned  blinks on the display. All other indicators disappear. Let go.



2 The indicator of the function concerned  continues to blink, push simultaneously on  and  keys while it's still blinking. The concerned function is deactivated.

Now when pressing the concerned command key , the indicator  doesn't appear on the handsets screen and no beep generated.

Radio range test



The procedure described below, allows verification that the radio signal between the handset(s) or the controller, with regard to the module is good.

THIS TEST IS ONLY POSSIBLE FOR PRODUCTS WHOSE RADIO RECOGNITION HAS BEEN DONE.



1 Press one of handsets keys (lighting or automatic device) with it in the place where it is usually located.

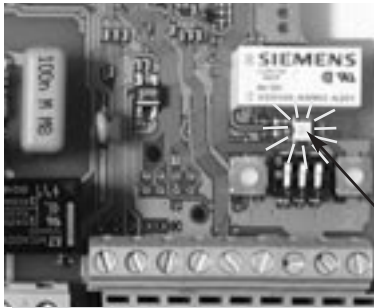

2 The modules LED lights (the relay concerned changes state) to indicate that it received the signal. If the LED doesn't light, remove the module (while following installation precautions) and restart the test to find the best location for the modules installation.

Flashing LED

In the case of automatic lighting, to test the radio signal between the Doorphones controller and the module, key in the main code and command release of either entrance. Verify that the LED of the module ignites briefly (relay 1 is closed).



Locating the module



Material necessary

- Drill and 6mm bit.
- Screwdriver cross-head Philips type (or standard pozidriv) for fixing No 2 screws.
- Screwdriver flat 3.5mm for adjusting terminal block screws.
- Crosshead screwdriver, Philips no.2, for captive screws and screws provided with the cable clamp.
- Fixing screws and wall anchors are supplied.



1 Use the wall mounting bracket to mark the 3 fixing points.



2 Drill 6mm holes.



3 Detach one of the washers and with one of screws provided fix the bottom part of the wall bracket. Detach the other washer (unused) so that it doesn't interfere with mounting the modules base. Fix the upper part of the bracket. Ensure the top part of the bracket remains as flat as possible after fixing. If necessary use a wedge (not supplied).



4 Hang the base onto the wall bracket starting from the top.

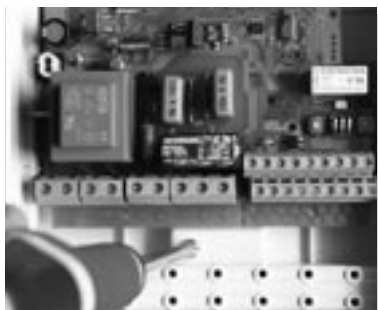

5 Lock the base with the locking screw.



6 Detach the antenna sleeve and to slip it on the antenna, from the top to the bottom.

Antenna sleeve



7 Screw the antenna tightly on the base of the module to avoid ingress of water into the module. Fully lower the antenna sleeve.

GB



Method of lighting control choice



The control of lighting can be either on/off or in timer mode, select the suitable option via the handset.

- In **on/off mode**, the first press of the handsets lighting command key lights the lamp (it remains lit). The next press of the lighting key will extinguish the light.
- In **timer mode**, a press of the handsets lighting key lights the lamp for a length of 30secs, 1 minute, 2 minutes, 4 minutes or 8 minutes (selectable). The illumination extinguishes at the end of this duration. Note that a further press of the key before the end of the duration will extinguish the lighting.



Attention: the choice of mode and the lighting duration is not possible unless the radio recognition has been done.

BEFORE YOU BEGIN, WE RECOMMEND YOU READ THE COMPLETE PROCEDURE.





1 Press the  key on the handset and keep it pushed until the  indicator blinks quickly on the display. The other indicators disappear. Let go of the key.

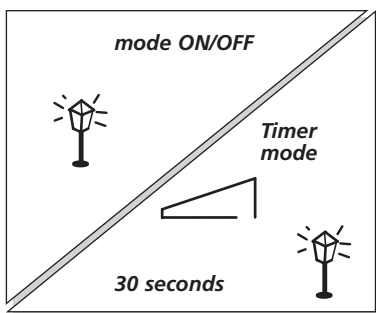

2 The  indicator continues to blink. Hold the  key again. The indicator  stops flashing. If not, after 5secs, restart the procedure from beginning.





3 The non-flashing  indicator means that you are in **ON/OFF mode**.

 and  indicators mean that you are in **timer mode** (Factory default duration 30s).

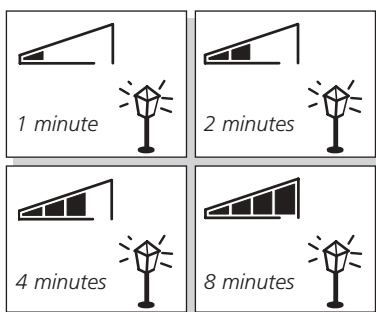
To toggle between one mode and the other press the  key (ensure less than 5secs duration between presses).



4 In timer mode, to increase or decrease the duration of lighting, press the  or  keys on the handset. It has the effect of adding to removing bars on the level indicator .



5 Press the  key to validate the choice. Note that without pressing this key, validation will automatically be made after 5secs.



ATTENTION: BEFORE WORK BEGINS, REMOVE THE MAINS POWER! THE INSTALLATION MUST BE IN LINE WITH ALL RELEVANT LEGISLATION.



- 1 Detach a cable grommet and pierce it sufficiently to permit the passage of the cable.

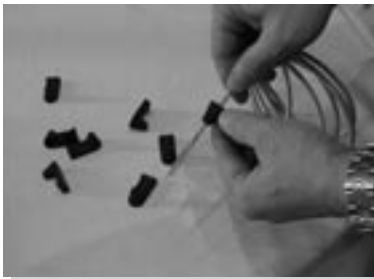

- 2 Cut cable to the necessary length. Pass the cable through the grommets. Strip the ends of the wires.

- 3 ***Carry out the necessary connections***

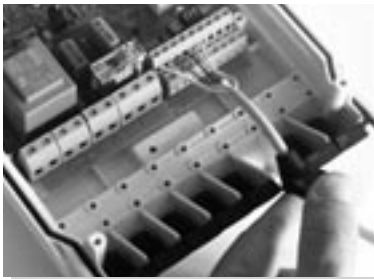

- 4 Fit the grommets in their slots on the base and fit all unused grommets necessary to guarantee the seal of the modules case.

Pay attention to the orientation of the grommets!



- 5 Use the screws provided to secure the connected cables by screwing the cable clamp in place.

Do not cut up the cable clamp, keep it in one piece!



Simple switch type connection (1)

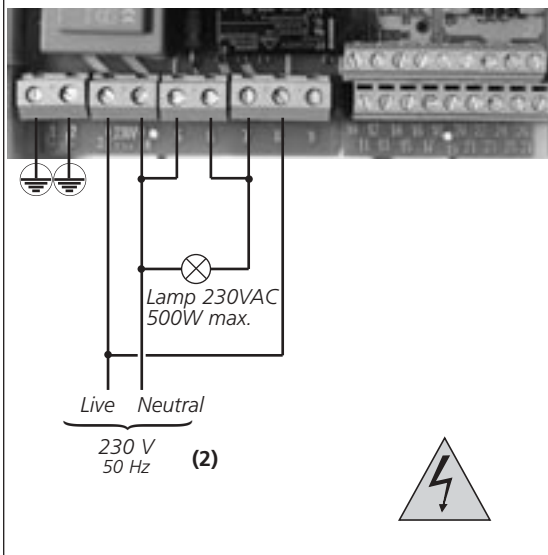

Connection of external override switch type (1)

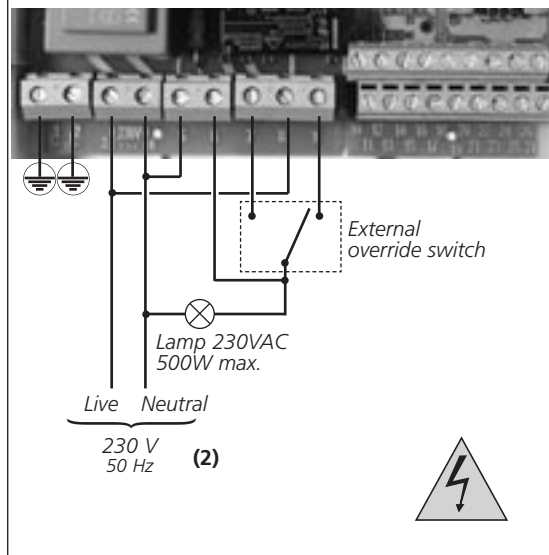

Connection of remote control type unit (1)

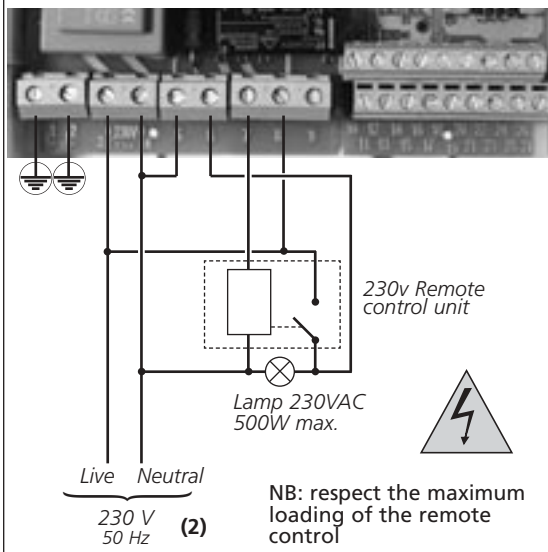

Connection of an automatic garage door device (use of relay 1)

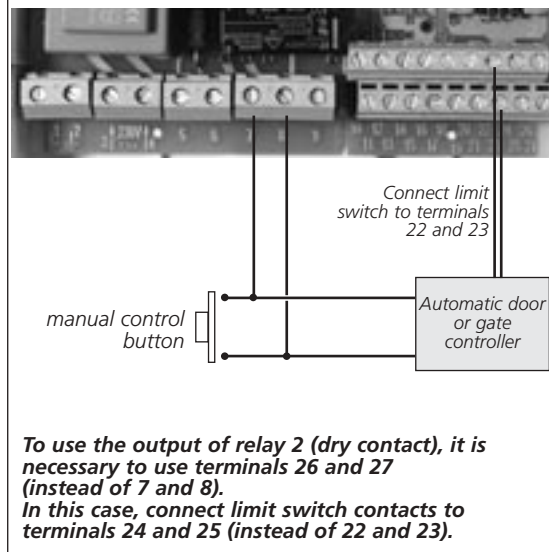





(1) Use 0.75 mm² or 1.5 mm² cable with outside diameter of 6 or 9mm for good efficiency.

(2) For safety, the mains supply must be protected by a differential 30mA cut-out and a 16A fused cut-out.



What to do if...?

Problem	Solution
When the radio recognition for one of the handset keys is done and I wish to proceed to the radio recognition of another key (same handset or other handset) it doesn't work.	It is necessary to wait a minimum of 20secs between two radio recognitions, one can shorten this period briefly by re-pressing one of the two pushbuttons in the module!
When I command the lighting from the handset, the lighting functions but sometimes the  indicator doesn't appear!	The distance between the handset and the module is too great and therefore the radio signal is insufficient. It is necessary to bring the items closer. Note that the state of the module is sent every 10mins to the handset.
When I press the  key, the  indicator doesn't appear anymore.	Re-do the radio recognition between the handset and the module. Verify that terminals 5 and 6 are connected correctly.
When I press the  key, the  indicator doesn't appear anymore.	Re-do the radio recognition between the handset and the module.
The radio recognition between the Doorphones controller and the module doesn't function.	Verify that switch 1 is OFF and that switch 3 is set to ONE. Re-do the radio recognition procedure from the beginning.

Technical characteristics:

- Supply: 230VAC or 12VDC or 12VAC
- Reliable radio transmission
- Radio range: 200m in free field
- Case: polycarbonate
- Operating temperature: -20°C to +50°C
- Ingress protection: IP54, dust and harmful deposits shield and sprays of water from all directions
- Output relay 1: RT relay (protected) for command of lighting or automatic device:
 - 230V load 500W max
 - 12V AC or DC 10A max
- Output relay 2: T relay (un-protected) for command of automatic device or to connect to a TBTS circuit:
 - 16V max, 22.6V peak max
 - 35 V continuous max
 - 500mA max
- Command of lighting : Simple switch type, override with command of the standard remote control unit ON/OFF mode or timer mode (duration : 30secs, 1min, 2mins, 4mins and 8mins)