

BX241

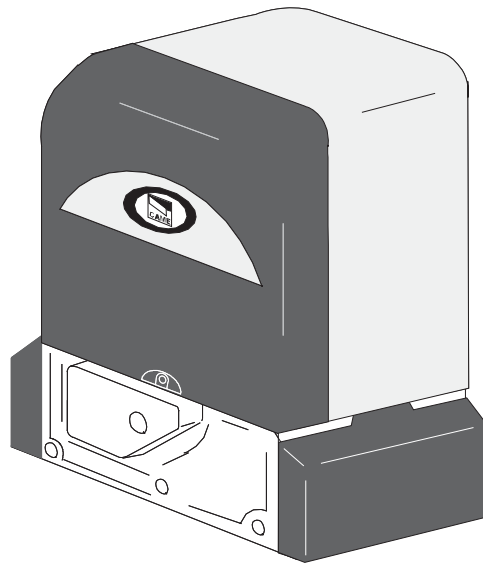

"IMPORTANT SAFETY INSTRUCTIONS FOR INSTALLATION"

"CAUTION: IMPROPER INSTALLATION MAY CAUSE SERIOUS DAMAGE, FOLLOW ALL INSTALLATION INSTRUCTIONS CAREFULLY"

"THIS MANUAL IS ONLY FOR PROFESSIONAL INSTALLERS OR QUALIFIED PERSONS"

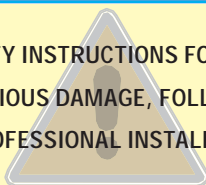

1 Legend



This symbol indicates sections to be read with particular care.



This symbol indicates sections concerning safety



This symbol indicates notes to communicate to users.

2 Destination and limits of use

2.1 Destination

The BX-241 ratiomotor is for the automation of sliding residential gates, even in cases of intense traffic.



The use of this product for purposes other than the one intended and installation carried out in a manner other than as instructed in this technical manual are prohibited.

2.2 Limits of use

For residential use: maximum gate weight 800 kg with maximum length of 14 meters.

For intensive or condominium use: maximum gate weight 600 kg with maximum length of 14 meters.

3 Standard followed

The following standard were complied with for this product: EN 12978, UNI EN 954-1, CEI EN 60335-1, UNI EN 12453.

4 Description

4.1 Gearmotor

The BX-241 ratiomotor is designed and built by CAME CANCELLI AUTOMATICI S.p.A. and it meets the safety standards in force. Guaranteed 24 months if not tampered with.

The casing is made up of a fused aluminium part where the irreversible electromechanical ratiomotor is housed and an ABS plastic-lined part that encloses the electronic board, the battery charger board and the bracket to house the two emergency batteries.

The BX-241 ratiomotor may be supplied with complementary accessories such as:

001 R001 - Lock cylinder with DIN keys;

001 BSF - Braking device for gates installed on a sloping surface;

001 BRC5/10/15 - Power supply cable winding device for sensitive safety profiles;

001 B4337 - Chain transmission device;

009 CGZ - Galvanized steel 22 x 22 module 4 rack;

009 CGZF - PA 6 nylon 20 x 32 module 4 rack with holes and fixing spacers;

009 CGZS - Galvanized steel 30 x 8 module 4 rack with fastening screws, holes and supports;

009 CCT - Simple 1/2" chain;

009 CGIU - 1/2" chain joint.

Important! Check that the safety equipment and accessories are CAME originals; this is a guarantee that also makes the system easy to set up and upkeep.

4.2 Technical information

BX-241 GEARMOTOR

Power supply: 230V A.C. 50/60Hz

Motor power supply: 24V D.C. 50/60Hz

Max. absorption: 17A

Rated power: 400W

Max. torque: *27 Nm

Reduction ratio: 1/33

Push: 700 N

Max. speed: 10 m/min

Operation intermittence: intensive with gates of up to 600 kg

Protection level: IP54

Weight: 15 kg

Operating temperature:



* Obtained with CAME control panel.

All the data and information contained herein is considered subject to change at any time and at our discretion

4.3 Parts description

GEARMOTOR UNIT

- 1 - Ratiomotor
- 2 - Board cover support
- 3 - End-stop flaps
- 4 - ZBX241 basic control board
- 5 - BN1 battery charger board
- 6 - Electric board front cover
- 7 - Release door
- 8 - Base plate
- 9 - Securing screws
- 10 - Plates for securing screws
- 11 - Nuts

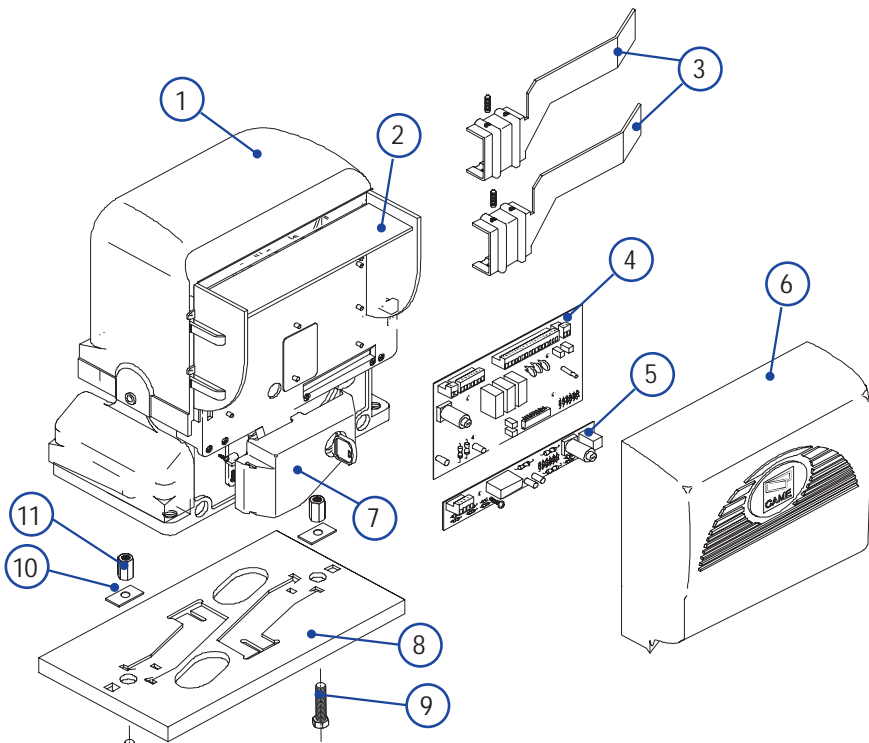

ACCESSORIES

- 1 - R001 - Cylinder lock with DIN keys
- 2 - BSF - Braking device
- 3 - BRC - Cable winding device
- 4 - B4337 - Chain transmission device
- 5 - CCT - Simple 1/2" chain
- 6 - CGIU - 1/2" chain joint
- 7 - CGZ - Galvanized steel 22 x 22 module 4 rack
- 8 - CGZF - PA 6 nylon 20 x 32 module 4 rack with holes and fixing spacers
- 9 - CGZS - Galvanized steel 30 x 8 module 4 rack with fastening screws, holes and supports

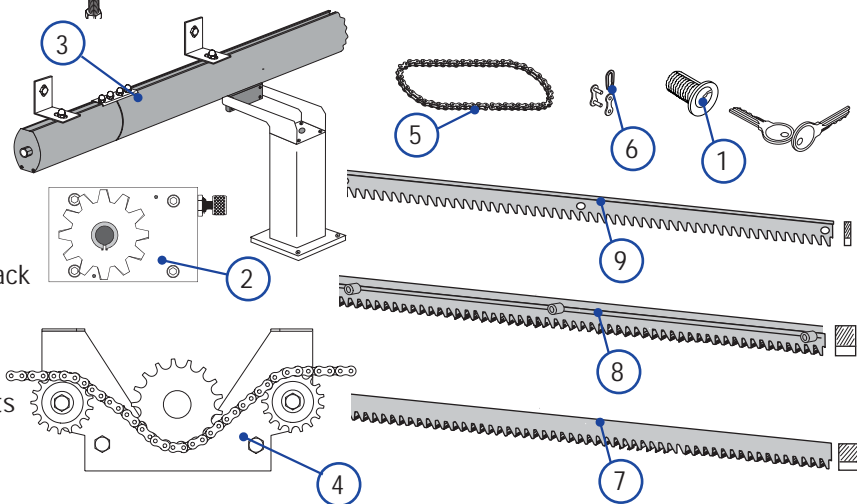

4.4 Size measurements

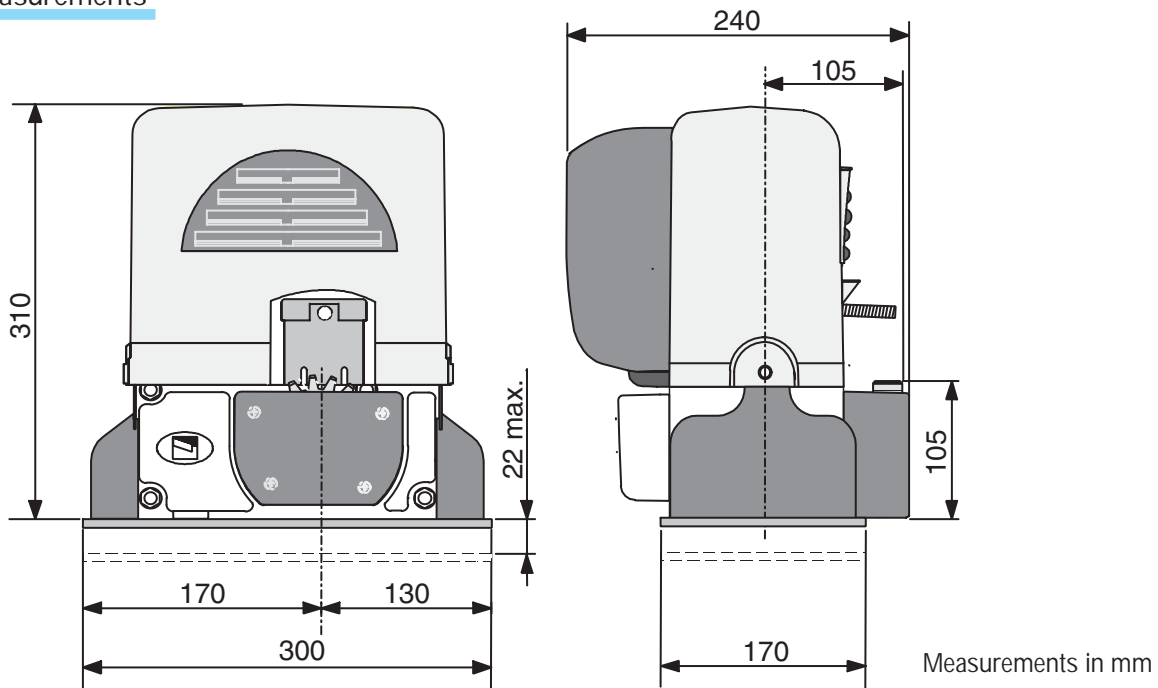

All the data and information contained herein is considered subject to change at any time and at our discretion

5 Installation

⚠ Installation must be carried out by expert qualified personnel and in full observance of regulations in force.

5.1 Preliminary checks

⚠ Before proceeding with the installation, it is necessary to:

- Make sure the door is rigid and compact and that the sliding wheels are well oiled and in good condition.
- The ground guide must be well fastened to the ground, fully on the surface for the entirety of its length and without irregularities that might obstruct the gate's movement.
- The upper guide runners must not create friction.
- Provide for a gate stopper for opening and one for closing, and for the path of electrical cables as per standard system.
- Make sure the point in which the ratiomotor is fixed is in an area protected from shocks or bumps, and that the anchoring surface is solid.
- Provide for suitable omnipolar disconnection device with more than 3 mm between contacts to section power supply.
- Ⓢ Connections inside the case made for protection circuit continuity are allowed as long as they include additional insulation with respect to other internal drive parts.
- Install suitable tubes and ducts for electric cable passage to guarantee protection against mechanical damage.

5.2 Tools and materials

Make sure all tools and materials necessary are within reach to install the edge in maximum safety, according to regulations in force. The following figure illustrates the minimum equipment for the installer.

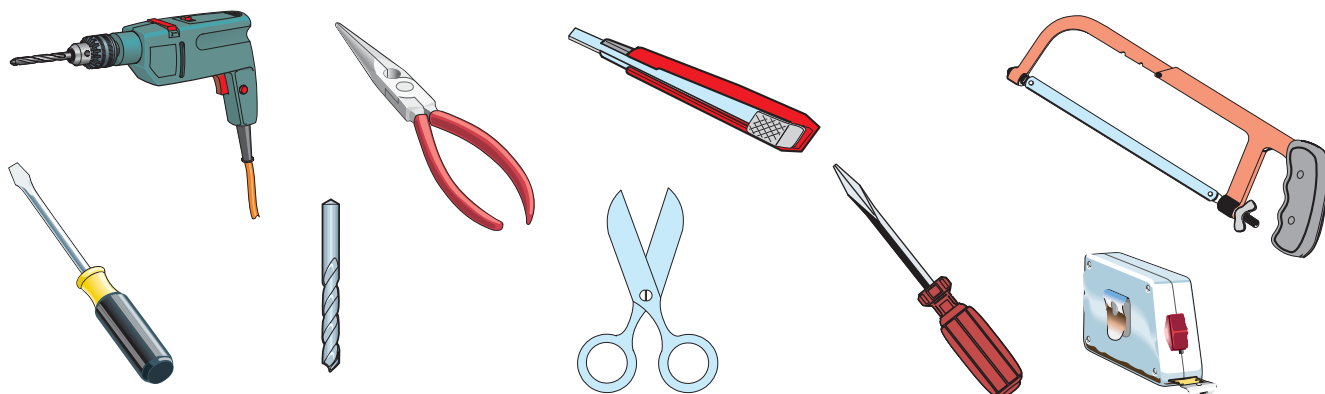

5.3 Cable list and minimum thickness

Connections	Type of cable	Length of cable 1 < 10 m	Length of cable 10 < 20 m	Length of cable 20 < 30 m
230V 2F power supply	FROR CEI 20-22 CEI EN 50267-2-1	3G x 1,5 mm ²	3G x 2,5 mm ²	3G x 4 mm ²
24V motor power supply		2 x 1 mm ²	2 x 1,5 mm ²	2 x 2,5 mm ²
24V - 230V flashing lamp		2 x 0,5 mm ²	2 x 1 mm ²	2 x 1,5 mm ²
Photoelectric cells TX		2 x 0,5 mm ²	2 x 0,5 mm ²	2 x 0,5 mm ²
Photoelectric cells RX		4 x 0,5 mm ²	4 x 0,5 mm ²	4 x 0,5 mm ²
24V power supply accessory		2 x 0,5 mm ²	2 x 0,5 mm ²	2 x 1 mm ²
Control button		2 x 0,5 mm ²	2 x 0,5 mm ²	2 x 0,5 mm ²
End stop	3 x 0,5 mm ²	3 x 1 mm ²	3 x 1,5 mm ²	
Encoder connection	2402C 22AWG	max. 30 m		
Antenna connection	RG58	max. 50 m		

N.B.: An evaluation of the size of the cables with lengths other than the data in the table must be made based on the effective absorption of the connected devices, according to the instructions indicated by the CEI EN 60204-1 standards. For connections that require several loads on the same line (sequential), the size given on the table must be re-evaluated based on actual absorption and distances.

- 1- BX-241 unit
- 2- Control board incorporated
- 3- Radio receiver
- 4- Limit-switch tabs
- 5- Rack
- 6- Key-operated selector switch
- 7- Flashing light indicating door movement
- 8- Antenna
- 9- Safety photocells
- 10- Photocell column
- 11- Closure stop

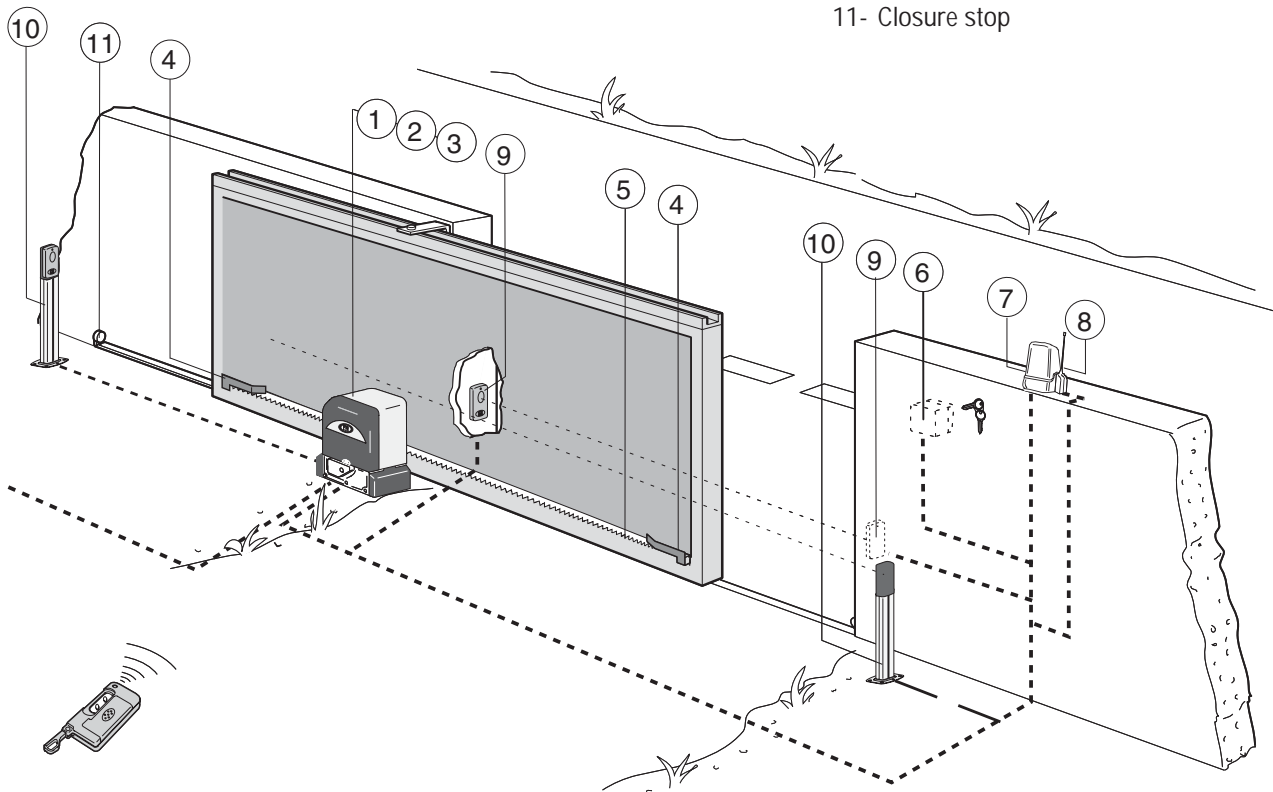

All the data and information contained herein is considered subject to change at any time and at our discretion

5.4 Motor to base anchorage



The following applications are only examples, as the space required for unit installation and the accessories vary depending on dimensions and therefore it is up to the installer to select the best solution.

- Install the screws in the anchor plate and fasten them with a nut, then bend the preformed clamps downwards.
- Construct a cement foundation that is large enough to accommodate the gear motor (it is a good idea to protrude 50 mm. from the ground). When pouring the foundation, embed the gear motor anchor plate and the relative clamps in the cement.
- The anchor bolts should be embedded in the concrete in the positions indicated; the drive unit is then attached to these bolts. The anchor plate must be perfectly level and absolutely clean; the bolts threads must be completely exposed.

N.B.: The flexible tubes for the electrical wiring must be embedded in the base and protrude in the correct position.

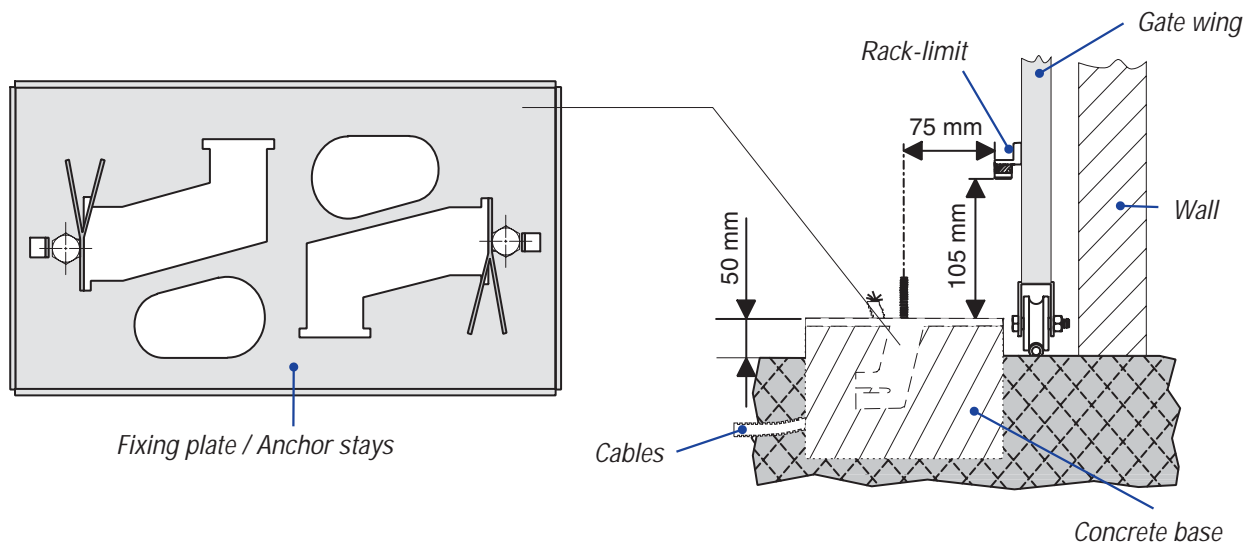

5.5 Unit installation

During the initial phase of installation, the feet should protrude by 5-10 mm. in order to allow for alignment, anchorage of the rack and further adjustments.

Perfect alignment with the guide rail is made possible by the (paten-*ted*) built-in regulation system, which consists of:

- slots for horizontal adjustment;
- threaded steel feet for vertical adjustment and levelling;
- plates and bolts for anchorage to the base.

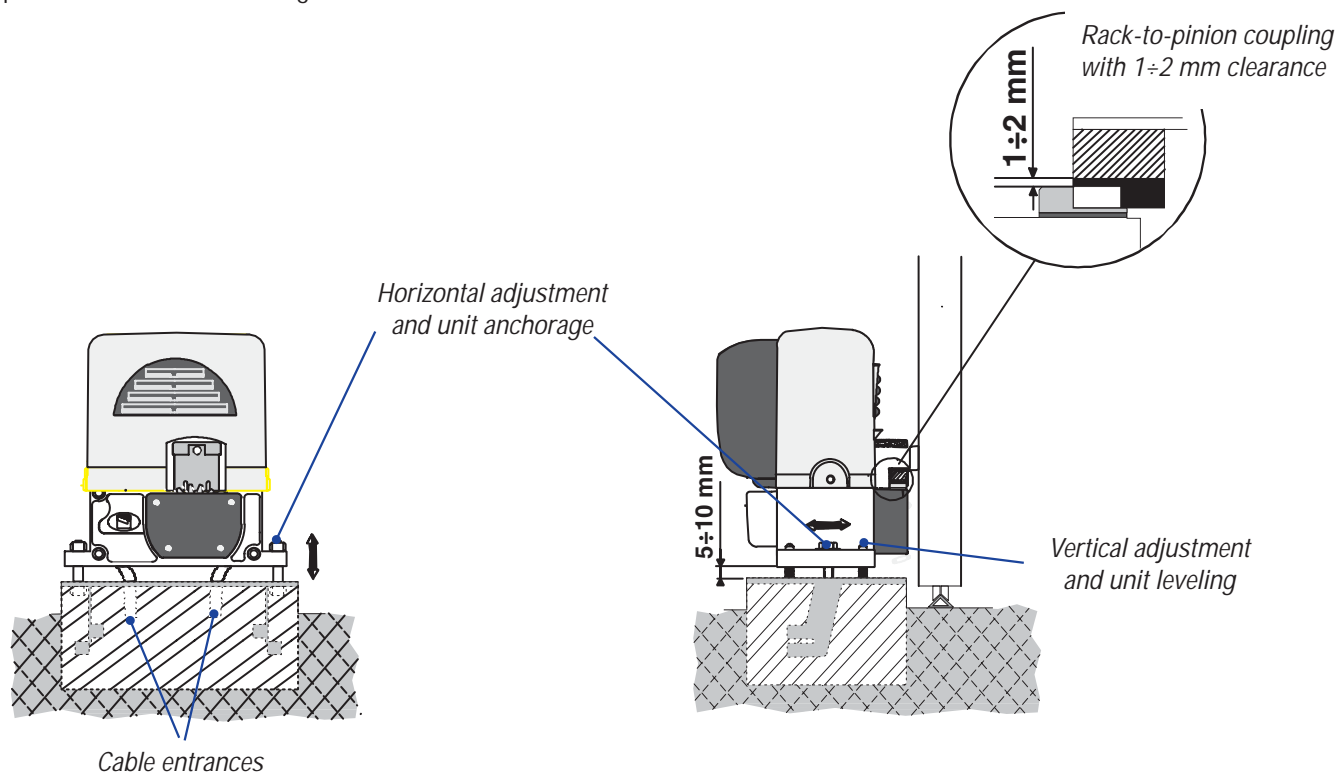

5.6 Attaching the rack/limit

Attach the rack to the gate as described below:

- Release the gearmotor (parag. 5.8);
- position the rack on the pinion of the gearmotor and slide the gate manually in order to attach the rack along its entire length;
- when the rack is attached to the gate, adjust the feet using a screwdriver until the play between the pinion and the rack is correct (1-2 mm.).

N.B.: This position ensures that the weight of the gate does not rest on the gearmotor.

- If the rack is already attached, proceed directly to the adjustment of the rack/pinion coupling.
- when the necessary adjustment have been completed, fasten the unit in position by tightening the two anchor bolts.

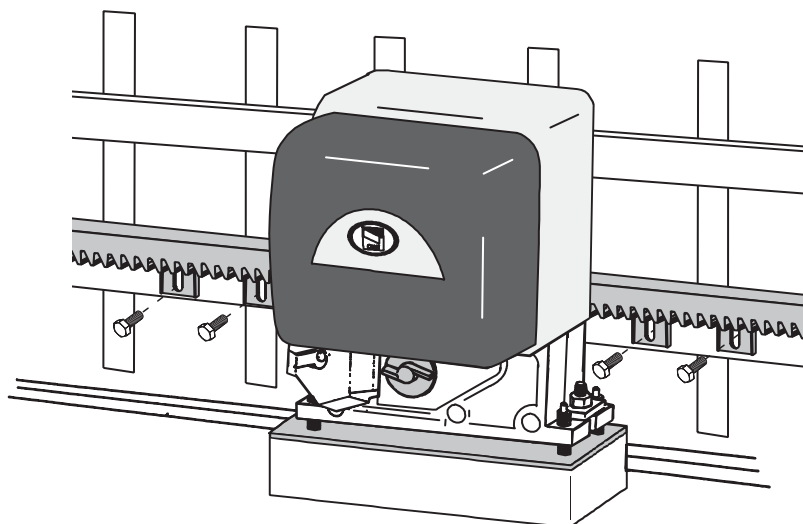

5.7 Attaching the switch tabs

Position the limit-switch tabs (whose positions determine the limits of gate travel) on the rack.

Note: do not allow the gate to strike the mechanical stops in the open or closed positions.

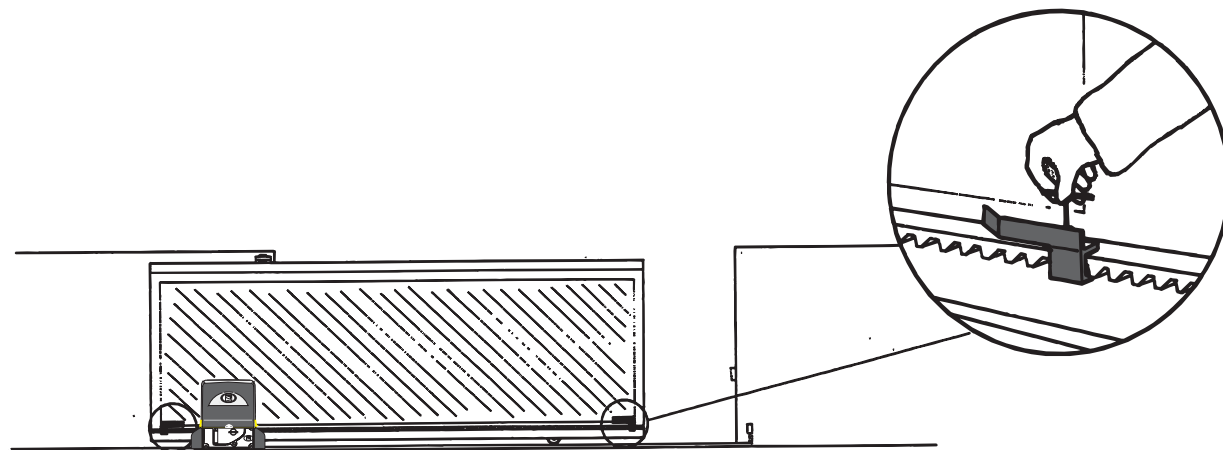

5.8 Gear release

To open the access door, insert the key, push down and rotate clockwise. Now, release the gear motor by rotating the knob in the direction shown.

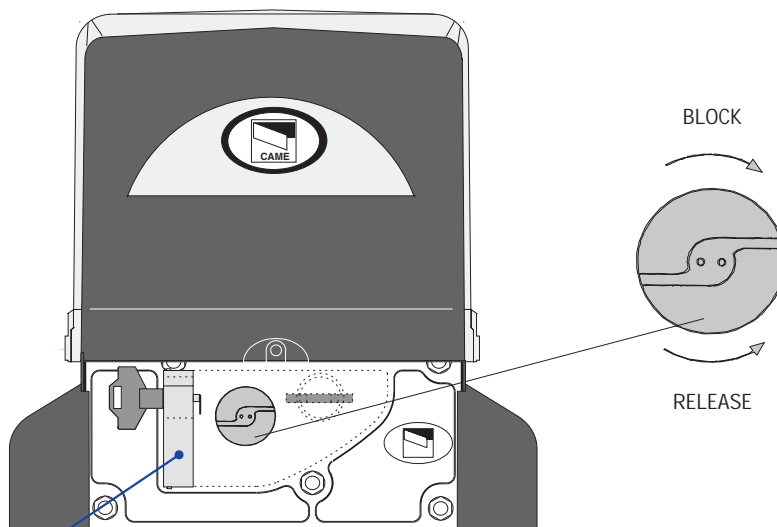

⚠ ATTENTION: the opening of the unblock panel arrests the motor.

All the data and information contained herein is considered subject to change at any time and at our discretion

6 Control board

6.1 Technical description board ZBX241

This control board is powered by 230V a.c. across terminals L1 and L2, and is protected by a 1A fuse on the main power line. Control systems are powered by low voltage and protected with by a 1.6A fuse. The total power consumption of 24V accessories must not exceed 40 W. Fixed operating time of 90 seconds.

Photocells can be connected to obtain:

- Re-opening during the closing cycle;
- Partial stop: shutdown of moving gate, with activation of an automatic closing cycle;
- Total stop: shutdown of gate movement without automatic closing; a pushbutton or radio remote control must be actuated to resume movement;

The board, moreover, integrates and independently runs a safety function capable of detecting obstacles that hinder movement: during opening: the gate stops and the automatic closure is activated;

during closure: the gate inverts its direction until it is completely open, after which it closes automatically.

⚠ Warning! after three consecutive inversions, the gate will remain open and automatic closure will be discontinued. To close the gate, use the radio remote control or the push-button.

Other functions available:

Automatic closing: The automatic closing timer is automatically activated at the end of the opening cycle. The preset, adjustable automatic closing time is automatically interrupted by the activation of any safety system, and is deactivated after a total stop command or in case of power failure;

- Partial opening function: opening of the gate to the desired position for pedestrian passage, which can be adjusted on the trimmer;
- Detection of obstacles: this function cancels every command if the photocells (in whatever safety function connected) detect an obstacle with the gate at the limit position;
- "Human presence" operation;
- Flashing light activated before opening and closing cycle begins;
- Selection of command sequence: open-close-reverse, open-stop-close-stop or open only.

Adjustments: automatic closing time, partial opening time and amperometric sensitivity.

⚠ IMPORTANT:- the opening of the unblock panel arrests the motor.

- Shut off the mains power and disconnect the batteries before servicing the inside of the unit.

6.2 ZBX241 main components

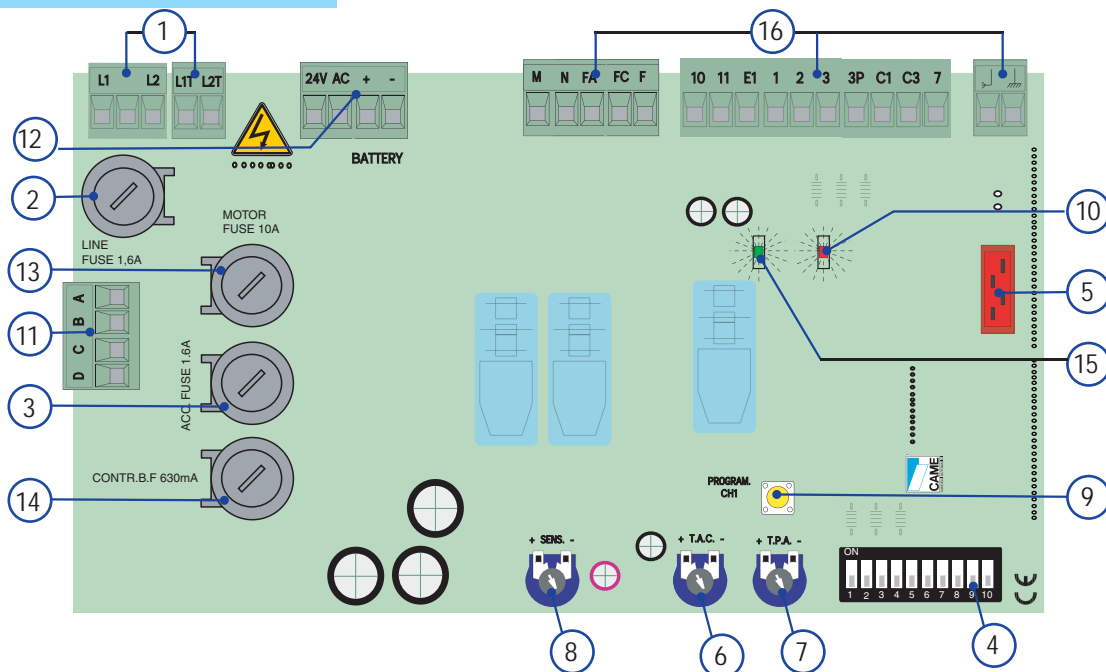

1 – Power supply connection terminal board and transformer

2 - 1A line fuse

3 - 1.6A accessory fuse

4 - "Function selection" dip-switch

5 - Radiofrequency board slot

6 - TCA trimmer: automatic closing time adjustment

7 - AP.PARZ. trimmer: partial aperture adjustment

8 - SENS. trimmer: amperometric sensitivity adjustment

9 - Code memorising key

10 - LED indicator for radio codes

11 - BN1 board connecting terminal board

12 - Emergency battery connecting terminal board

13 - 10A motor fuse

14 - 630mA control unit fuse

15 – Power supply LED indicator

16 - Motor, end-stop and accessory connecting terminal board

6.3 Description board BN1

The BN1 board allows the automation to be battery operated in case of a power outage. When power is restored, the card also recharges the batteries.

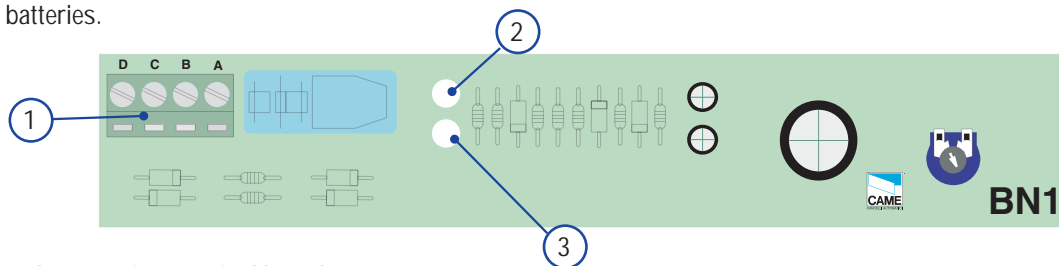

- 1 - ZBX241 board connecting terminal board
- 2 - The green LED indicator light signals mains power supply on
- 3 - The red LED indicator light signals emergency battery power supply on

6.4 Emergency battery connection

Insert batteries in the appropriate bracket (Fig.1) and connect them (using the cables provided) to the ZBX241 board (Fig.2) terminal (+,-).

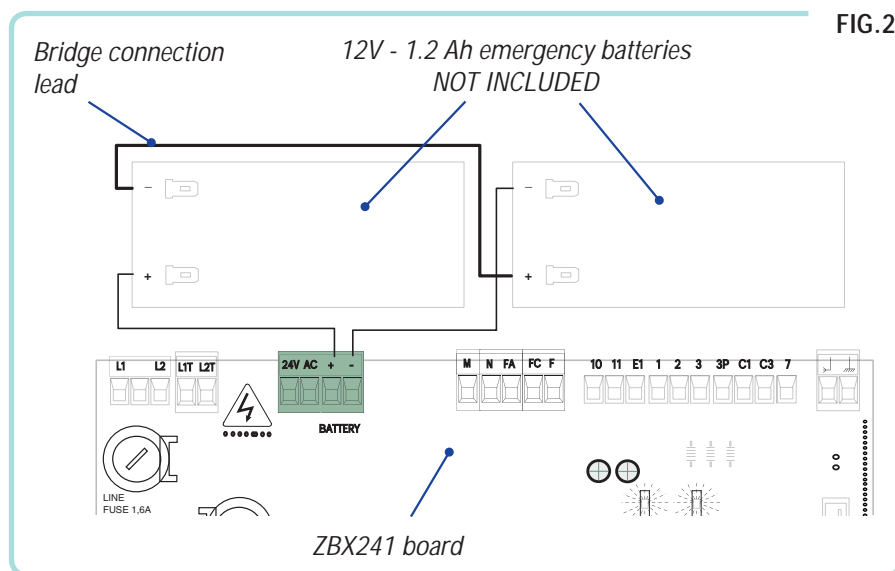
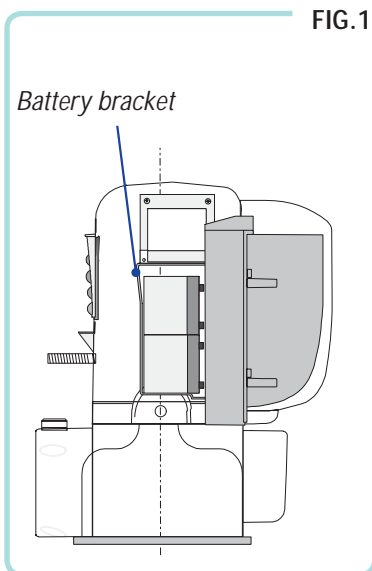

6.5 Gearmotor end-stop connection

The motor and limit switch unit are wired at the factory for mounting on the left-hand side of the gate (as seen from the inside). If right-hand installation is desired:

- invert limit switch connections FA-FC on the terminal block;
- invert motor phase connections M-N on the terminal block.

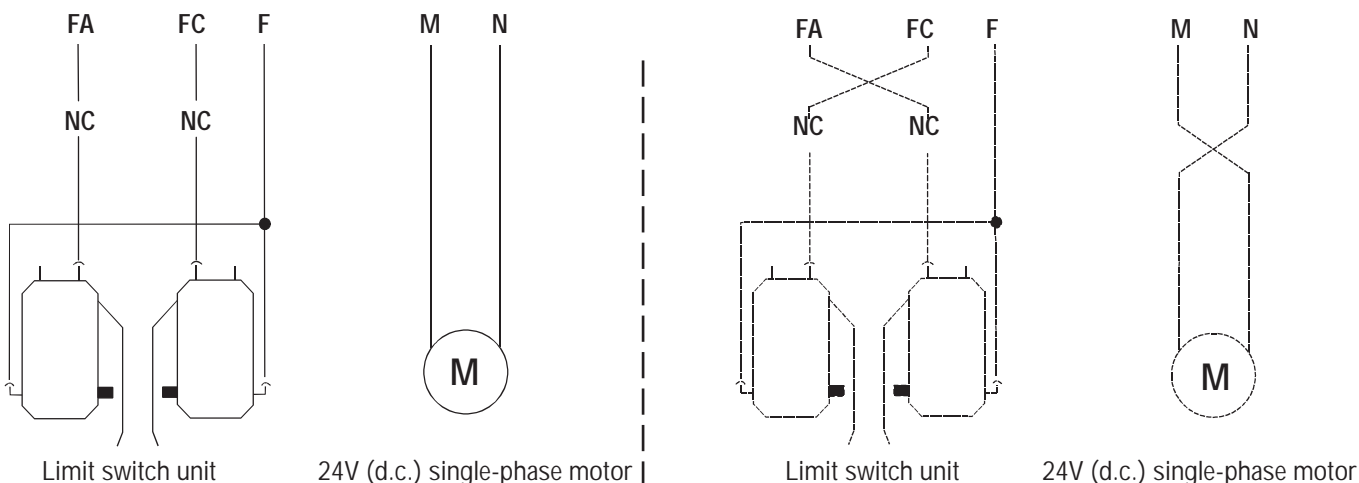

All the data and information contained herein is considered subject to change at any time and at our discretion

6.6 Electrical connections



L1		230V (a.c.) power supply
L2		
M		24V(d.c.) motor
N		
11		24V output in motion (e.g. flashing light 25W)
E		
+10		24V powering accessories max. 40W
-11		
1		Pushbutton stop (N.C.)
2		
2		Pushbutton open (N.O.)
3		
2		Pushbutton partial opening (N.O.)
3P		
2		Contact radio and/or pushbutton for controlled (see dip-switch 2-3)
7		
2		Contact (N.C.) for «re-aperture during closure»
C1		
2		Contact (N.C.) for «partial stop»
C3		
2		(24V-3W max.) gate-opened signal lamp
FC		
F		Connection limit switch opens
FA		
F		Connection limit switch closes
FC		
		Antenna connection

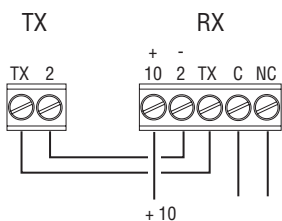

N.B. Maintain polarity when connecting photoelectric cells (DIR)

6.7 Function selections



- 1 ON - Automatic closure enabled
- 2 ON - "Open-stop-close-stop" radio control and/or button function enabled (with plug-in radiofrequency board)
- 2 OFF - "Open-close-reverse" radio control and/or button function enabled (with plug-in radiofrequency board)
- 3 ON - "Only open" radio control and/or button function enabled (with plug-in radiofrequency board)
- 4 ON - "Maintained action" operation enabled
- 5 ON - Pre-flashing (aperture and closure) enabled
- 6 ON - Obstacle detection device (motor of limit position) enabled
- 7 OFF - Re-aperture in closure phase enabled; activate safety device (2-C1), if not set the dipswitch to ON
- 8 OFF - "Stop" button enabled; activate safety device (1-2), if not set the dipswitch to ON
- 9 OFF - "Partial-stop" enabled; activate safety device (2-C3), if not set the dipswitch to ON
- 10 Not used

6.8 Adjustments

- Trimmer TCA = Automatic closing time: 1" to 120";
- Trimmer AP.PARZ. = Partial opening time: 1" to 15".
- Trimmer SENS.= amperometric sensitivity adjustment



7 Installation procedure of the transmitter for remote control



Read the three steps below before beginning installation procedures:

- prepare the radio board (paragraph 7.1);
- procedure for codifying the transmitter (paragraph 7.2);
- memorizing the code on the command board (paragraph 7.3).

7.1 Prepare the radio board (AF)

1) On AM transmitters operating at 433.92 MHz (TOP and TAM series), position the jumper connection on circuit card AF43S as shown on the sheet.

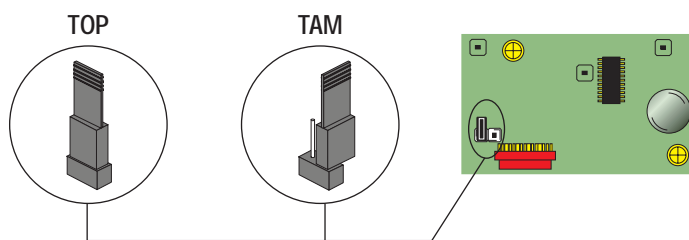

2) The AF board should ALWAYS be inserted when the power is off.

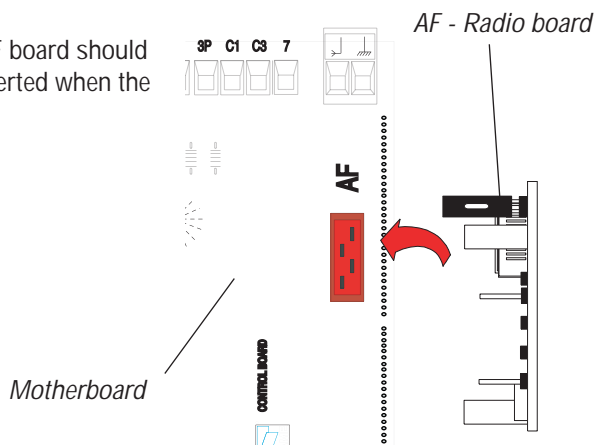

Frequency/MHz	Radiofrequency	Transmitter
FM 26.995	AF130	TFM
FM 30.900	AF150	TFM
AM 26.995	AF26	TOP
AM 30.900	AF30	TOP
AM 433.92	AF43S / AF43SM	TAM / TOP
AM 433.92	AF43SR	ATOMO
AM 40.685	AF40	TOUCH

7.2 Procedure for codifying the transmitter

TOP QUARTZ SERIES

Standard encoding procedure T262M - T264M - T2622M - T302M - T304M - T3022M

1 assign a code (also on file)

P1	<input type="checkbox"/>	<input type="checkbox"/>	<input type="checkbox"/>	<input type="checkbox"/>	<input type="checkbox"/>	<input type="checkbox"/>	<input type="checkbox"/>	<input type="checkbox"/>	<input type="checkbox"/>	<input type="checkbox"/>	OFF
P2	<input type="checkbox"/>	<input type="checkbox"/>	<input type="checkbox"/>	<input type="checkbox"/>	<input type="checkbox"/>	<input type="checkbox"/>	<input type="checkbox"/>	<input type="checkbox"/>	<input type="checkbox"/>	<input type="checkbox"/>	ON
	1	2	3	4	5	6	7	8	9	10	

2 connect encoding jumper J

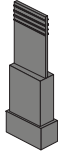

3 register code

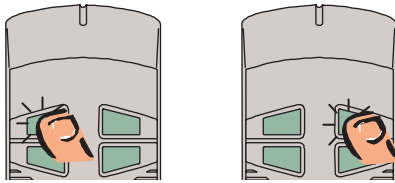

Press P1 or P2 in sequence in order to register the code; at the tenth pulse, a double beep will confirm that registration has occurred

4 disinsere jumper J

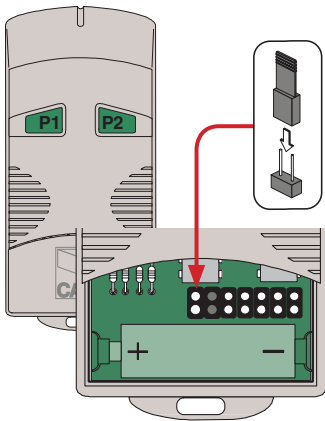
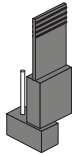

TOP
T262M - T302M

The first encoding operation must be carried out whilst keeping the jumpers positioned for channels 1 and 2 as per fig. A; see fig. B for any subsequent settings on different channels.

FIG.A

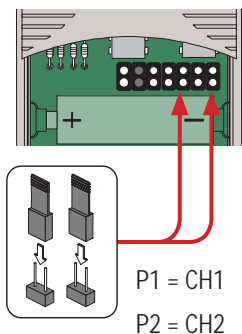
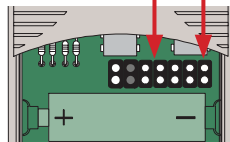
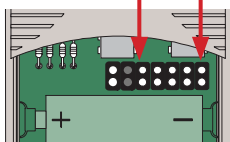

FIG.B

P1 = CH1 - P2 = CH3



P1 = CH1 - P2 = CH4



P1 = CH3 - P2 = CH2

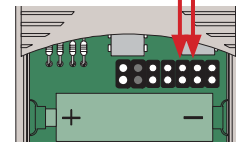

P1 = CH3 - P2 = CH4

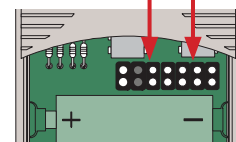

T264M - T304M

P1 = CH1
P2 = CH2
P3 = CH3
P4 = CH4

T2622M - T3022M

1° Code
P1 = CH1
P2 = CH2

2° Code
P3 = CH1
P4 = CH2

P1	<input type="checkbox"/>	<input type="checkbox"/>	<input type="checkbox"/>	<input type="checkbox"/>	<input type="checkbox"/>	<input type="checkbox"/>	<input type="checkbox"/>	<input type="checkbox"/>	<input type="checkbox"/>	<input type="checkbox"/>	OFF
P2	<input type="checkbox"/>	<input type="checkbox"/>	<input type="checkbox"/>	<input type="checkbox"/>	<input type="checkbox"/>	<input type="checkbox"/>	<input type="checkbox"/>	<input type="checkbox"/>	<input type="checkbox"/>	<input type="checkbox"/>	ON
	1	2	3	4	5	6	7	8	9	10	

TOP SERIES

TOP
T432M - T312M

set the code to dip-switch C and channel to D (P1=CH1 and P2=CH2, default setting)

TOP
T432M - T312M

P1

<input type="checkbox"/>	<input type="checkbox"/>	<input type="checkbox"/>	<input type="checkbox"/>
ON	↑	1	2

CH1

<input type="checkbox"/>	<input type="checkbox"/>	<input type="checkbox"/>	<input type="checkbox"/>
ON	↑	1	2

CH2

<input type="checkbox"/>	<input type="checkbox"/>	<input type="checkbox"/>	<input type="checkbox"/>
ON	↑	1	2

CH3

<input type="checkbox"/>	<input type="checkbox"/>	<input type="checkbox"/>	<input type="checkbox"/>
ON	↑	1	2

CH4

P2

<input type="checkbox"/>	<input type="checkbox"/>	<input type="checkbox"/>	<input type="checkbox"/>
ON	↑	1	2

CH1

<input type="checkbox"/>	<input type="checkbox"/>	<input type="checkbox"/>	<input type="checkbox"/>
ON	↑	1	2

CH2

<input type="checkbox"/>	<input type="checkbox"/>	<input type="checkbox"/>	<input type="checkbox"/>
ON	↑	1	2

CH3

<input type="checkbox"/>	<input type="checkbox"/>	<input type="checkbox"/>	<input type="checkbox"/>
ON	↑	1	2

CH4

TOP
T434M - T314M

set code only

P1 = CH1
P2 = CH2
P3 = CH3
P4 = CH4

TOP
T432S - T432SA - T434MA - T432NA - T434NA

see instructions on pack

TAM
T432 - T434 - T438 - TAM432SA

see instruction sheet inside the pack

TFM
T132 - T134 - T138
T152 - T154 - T158

see instruction sheet inside the pack

ATOMO SERIES



AT01 - AT02 - AT04

see instruction sheet inside the pack of AF43SR circuit card



TOUCH SERIES

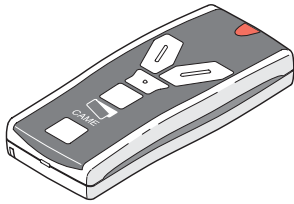

TCH 4024 - TCH 4048

see instructions on pack

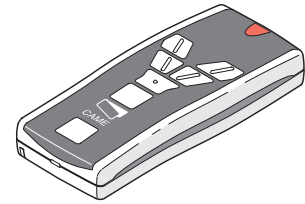

7.3 Memorizing the code on the command board

1) Keep the "CH1" key pressed on the base card, the signal LED will flash.

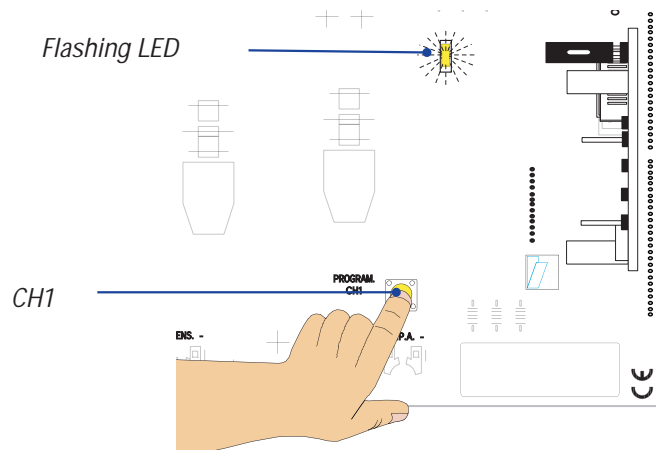

2) Press a transmitter key to send the code; the LED will remain lighted to signal memorization.

N.B.: if the code needs to be changed, repeat the sequence described above.

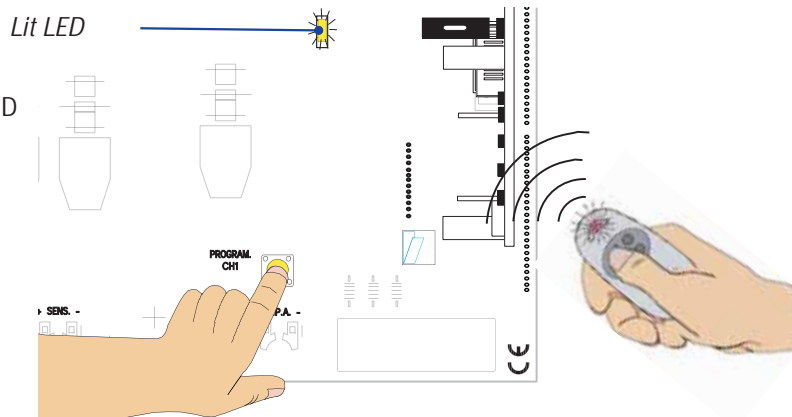

All the data and information contained herein is considered subject to change at any time and at our discretion

8 Maintenance

 The unit does not require specific maintenance. Only as a precautionary measure and in case of intensive use, we recommend periodic checks (every 6 months) on the state of the electric wire connected to the motor, the tightness of the nuts and the proper oiling of the sliding points between fixed and mobile parts.

All checks must be recorded (in a dedicated record-book).

9 Demolition and disposal

 In its premises, CAME CANCELLI AUTOMATICI S.p.A. implements an Environmental Management System certified in compliance with the UNI EN ISO 14001 standard to ensure environmental protection.

Please continue our efforts to protect the environment—which CAME considers one of the cardinal elements in the development of its operational and market strategies—simply by observing brief recommendations as regards disposal:

 **DISPOSAL OF PACKAGING** – The packaging components (cardboard, plastic, etc.) are all classifiable as solid urban waste products and may be disposed of easily, keeping in mind recycling possibilities.

Prior to disposal, it is always advisable to check specific regulations in force in the place of installation.

PLEASE DISPOSE OF PROPERLY!

 **PRODUCT DISPOSAL** – Our products are made up of various types of materials. Most of them (aluminium, plastics, iron, electrical wires, etc.) may be disposed of in normal garbage collection bins and can be recycled by disposing of in specific recyclable material collection bins and disposal in authorized centres. Other components (electrical boards, remote control batteries, etc.), however, may contain polluting substances. They should therefore be removed and given to qualified service companies for proper disposal.

Prior to disposal, it is always advisable to check specific regulations in force in the place of disposal.

PLEASE DISPOSE OF PROPERLY!

10 Manufacturer's warranty



MANUFACTURER'S DECLARATION

As per Enclosure II B of Machinery Directive 98/37/CE

Enclosed with the technical documentation (the original copy of the Declaration is available on request)

Date of the present declaration 07/12/2001

The representatives of

CAME Cancelli Automatici S.p.A.
via Martiri della Libertà, 15
31030Dossan di Casier - Treviso - ITALYtel
(+39) 0422 4940 - fax (+39) 0422 4941
internet: www.came.it - e-mail: info@came.it

Hereby declare, under their own responsibility, that the product/s called ...

BX241

**R001 - BSF - BRC5 - BRC10 - BRC15 - B4337 - CGZ
CGZF - CGZS - CCT**

Also, they furthermore represent and warrant that the product/s that are the subject of the present Declaration are manufactured in the respect of the following main harmonized provisions:

EN 292 PART 1 AND 2	MACHINERY SAFETY.
EN 12453	INDUSTRIAL, COMMERCIAL AND OTHER CLOSING MECHANISMS.
EN 12445	INDUSTRIAL, COMMERCIAL AND OTHER CLOSING MECHANISMS.
EN 12978	SAFETY DEVICES FOR POWER OPERATED DOORS AND GATES
EN 60335 - 1	SAFETY IN APPARATUS FOR HOME USE.
EN 60204 - 1	MACHINERY SAFETY.
EN 61000 - 6 - 2	ELECTROMAGNETIC COMPATIBILITY.
EN 61000 - 4 - 4	ELECTROMAGNETIC COMPATIBILITY.
EN 61000 - 4 - 5	ELECTROMAGNETIC COMPATIBILITY.

IMPORTANT CAUTION!

It is forbidden to market/use product/s that are the subject of this declaration before completing and/or incorporating them in total compliance with the provisions of Machinery Directive 98/37/CE

Signatures of the Representatives

... comply with the Italian National Legal Provisions that transpose the following Community Directives (where specifically applicable):
MACHINERY DIRECTIVE 98/37/CE
LOW VOLTAGE DIRECTIVE 73/23/EEC - 93/68/EEC
ELECTROMAGNETIC COMPATIBILITY DIRECTIVE 89/336/EEC - 92/31/EEC
R&TTE DIRECTIVE 1999/5/CE

TECHNICAL MANAGER
Mr. Gianni Michielan

MANAGING DIRECTOR
Mr. Paolo Menuzzo

CAME UNITED KINGDOM LTD
UNIT 3, ORCHARD BUSINESS PARK TOWN
STREET, SANDIACRE
NOTTINGHAM - NG10 5BP - U.K.
Tel 0044 115 9210430
Fax 0044 115 9210431

