

# RODEO

AUTOMATION SYSTEM FOR SLIDING DOORS

***AUTOMATION SYSTEM FOR SLIDING DOORS,  
WITH MICROPROCESSOR CONTROL***

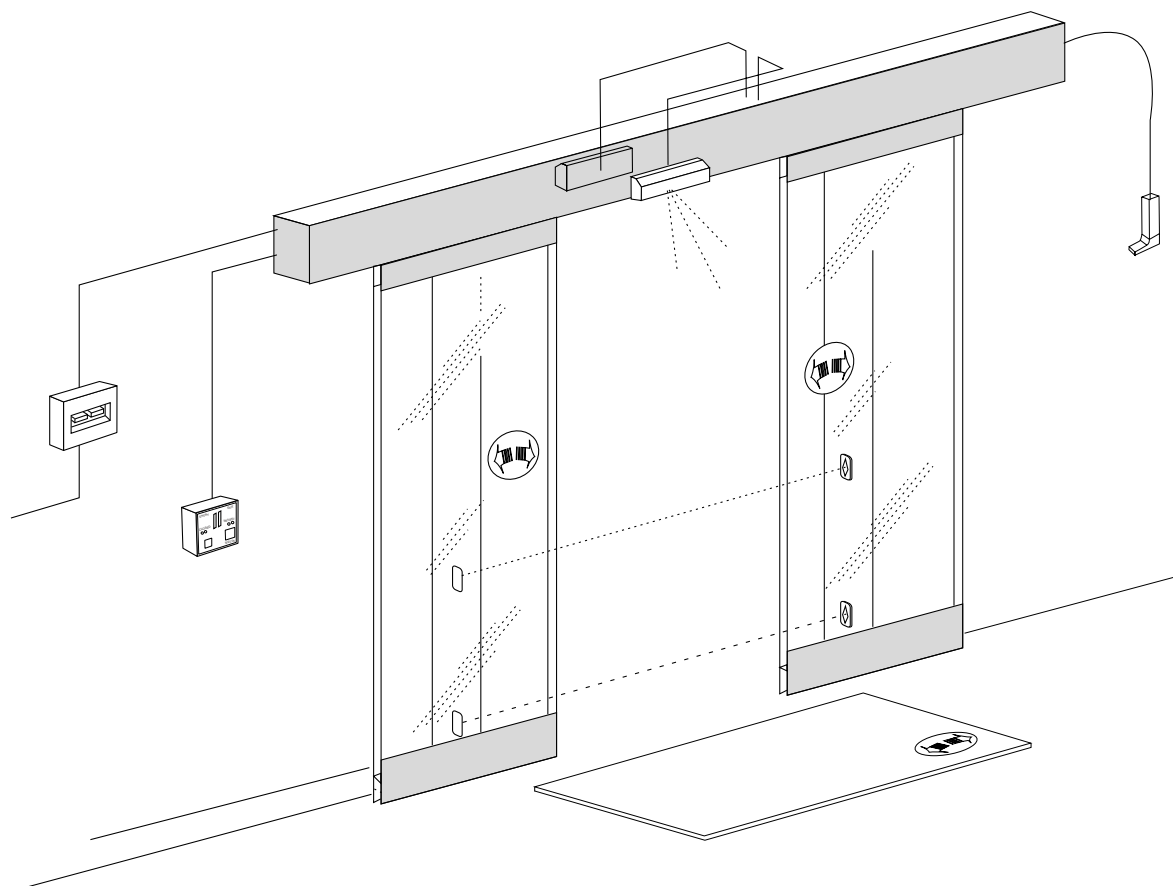

**for door wings weighting**

**up to 125 kg each**

**GENERAL CHARACTERISTICS**

**Description:**

System for sliding doors automatic opening.  
Designed and built entirely by CAME CANCELLI AUTOMATICI S.p.A. with IP40 protection level. 12-month warranty subject to tampering.

**Models:**

- **CORSA 1**, reversible 24V gear motor with integrated circuit board.  
Automation for single-door entrances up to 3,300 mm with weight max. 125 Kg.  
- **CORSA 2**, reversible 24V gear motor with integrated circuit board.  
Automation for entrances with 2 door up to 3,300 mm with weight max. 125 Kg per door.

**Optional accessories:**

- **MA7012** Electric lock;
- **MA7032** Battery-powered anti-panic system;
- **MA7041** Function selector;
- **MS9502** Touch-activated switch;
- **MF9011/9111** Command and safety photocells;
- **MR8001/8002** Infrared radar;
- **MR8104/8105** Microwave radar;
- **MR8334-70-90** Activ infrared safety sensor;
- **MP8030/8060** Pressure-sensitive;
- **MRT001** remote control for MR8104 e MR8105.

For easy installation and maintenance, be sure to use CAME original control equipment, safety systems and accessories.

**TECHNICAL SPECIFICATIONS**

VOLTAGE	FREQUENCY	MOTOR MAX CURRENT	NOMINAL CURRENT	POWER CONSUMPTION	DUTY CYCLE	DRIVE SYSTEM	MAX. FORCE EXERTED	OPENING SPEED	OPERATING TEMPERATURE
230V a.c. 24V a.c. ①	50/60 Hz	6A	(230V) 0,6A	Automation 90W Accessories 20W	②	HTD 8M toothed belt	8 Kg	45 cm/s Rodeo 1 80 cm/s Rodeo 2	-20°<+70°

(1) Upon request, there is the possibility of powering up the automation with a different voltage

(2) Heavy-duty-service

**IMPORTANT!**  
The following pages contain a provisional diagram of the trolley for the CORSA series. Although the dimensions and installation procedures for the RODEO series are indicated on the diagram, all references to RODEO and the ZP8 electrical cabinet also apply to CORSA and the ZP7 electrical cabinet.

**DIMENSIONS (1)**

The basic dimensions necessary for building a CAME automation system for automatic entrance control are door wing width **A** (or the total width of the two door wings) and the overall length **T** of the beam which contains the automation mechanism. The relationship between these two dimensions is as follows: **T = A x 2 + 20 mm**

**AUTOMATION SYSTEM FOR ENTRANCES WITH 2 DOOR WINGS**

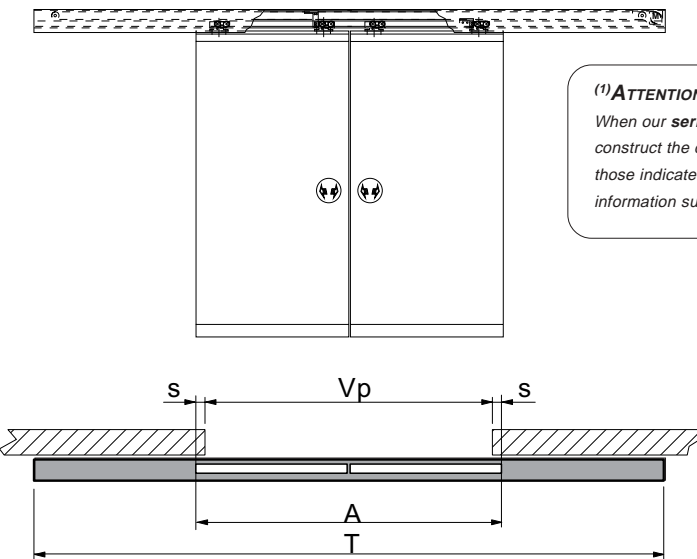

**AUTOMATION SYSTEM FOR ENTRANCES WITH 1 DOOR WING\*\***

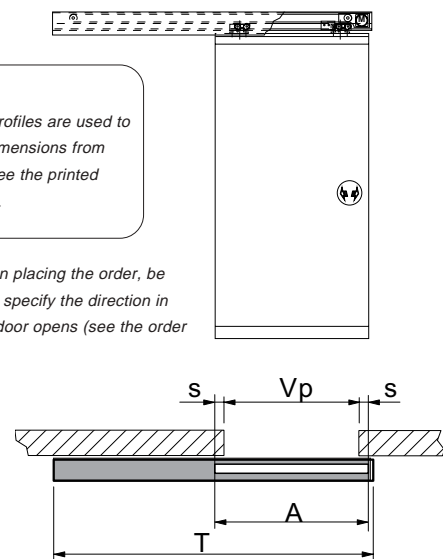

**(1)ATTENTION!**  
When our **series 20** and **series 40** profiles are used to construct the door wings, different dimensions from those indicated above may result. See the printed information supplied with the profiles.

\*\* When placing the order, be sure to specify the direction in which door opens (see the order form).

**BASIC DIMENSIONS**

- T** = Total length of beam
- A** = Total width of door wings, complete with weather stripping

**OTHER DIMENSIONS**

- Vp**= Passage area
- s** = Overlap between moving door wing(s) and fixed parts (walls and/or non-moving door wings)

# SECTION-COVERING BOXES DIMENSIONS

Drilling for fixing the section

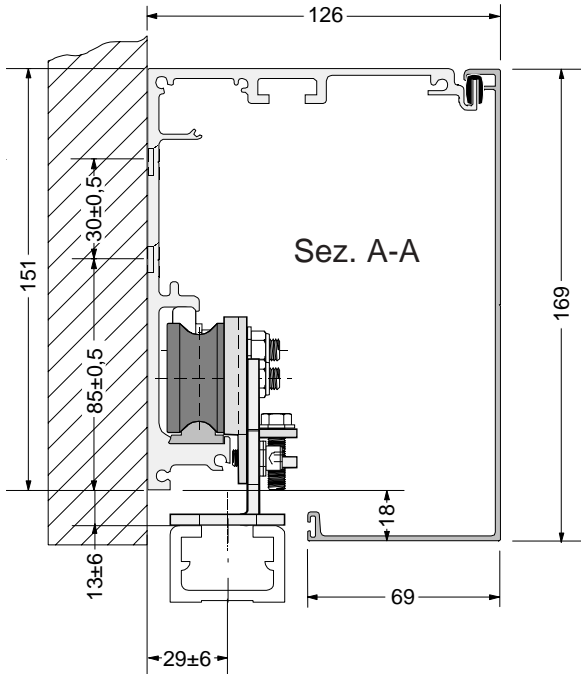
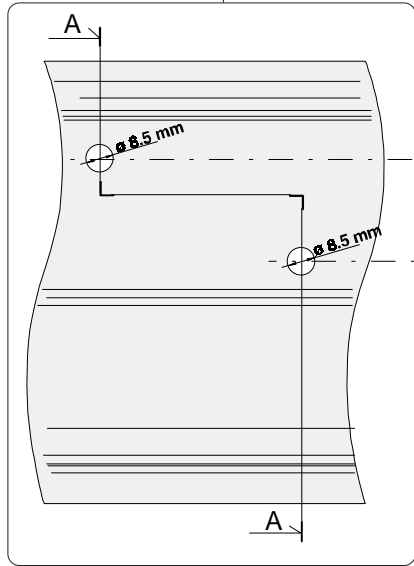
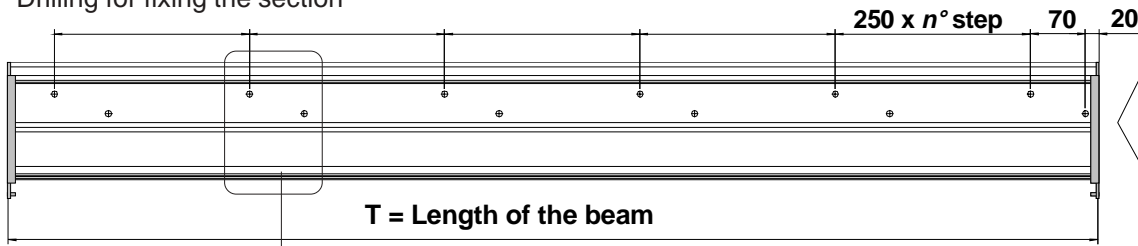

BEAM WITH SECTION-COVERING BOX SERIES 001LC00 AND LTC STOPPERS

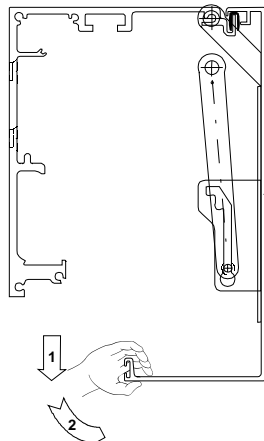
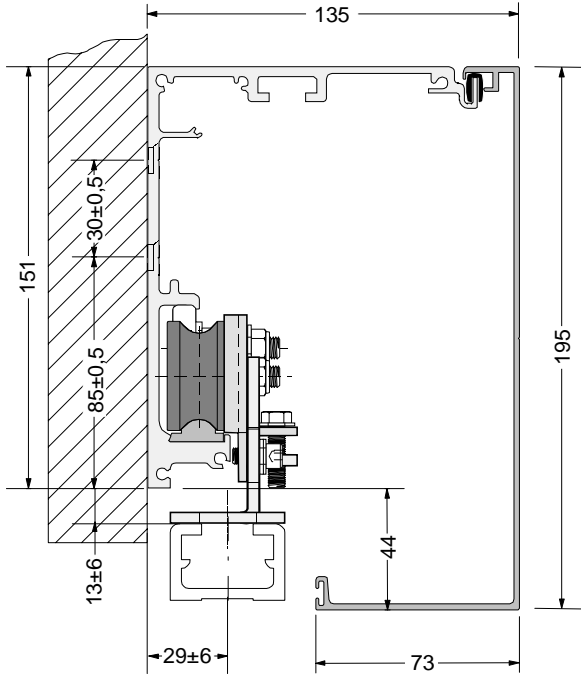

BEAM WITH SECTION-COVERING BOX SERIES 001LD00 AND LTD STOPPERS

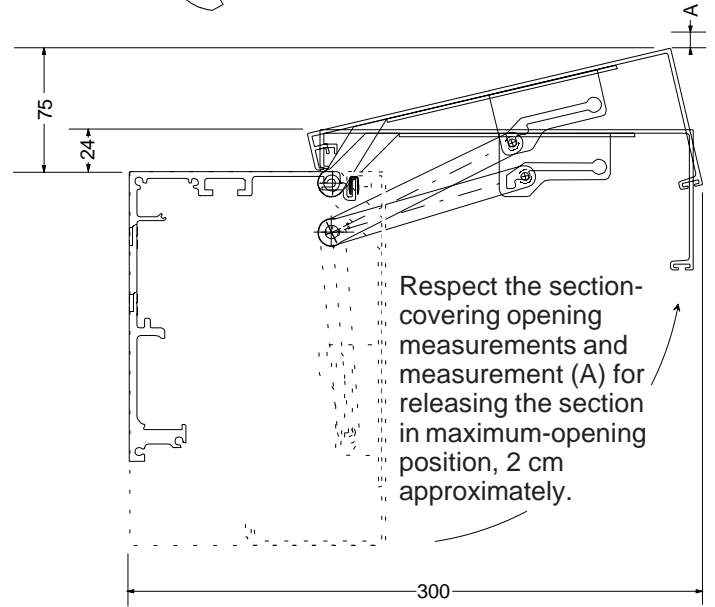

Respect the section-covering opening measurements and measurement (A) for releasing the section in maximum-opening position, 2 cm approximately.

The section-covering system Series 001LD00 has LTD side plugs in ABS and brackets that allow the section-covering to be supported in opening position.

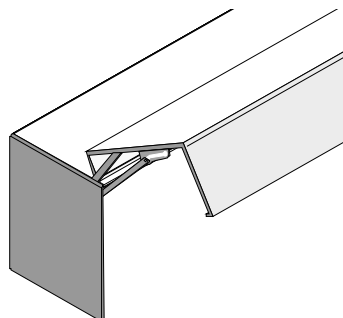

# DIAGRAMS OF GLASS DOOR WINGS

**Y** = height at which beam is mounted  
=  $H + 18 \text{ mm}$

**H** = working height of passage

**V** = height of glass door

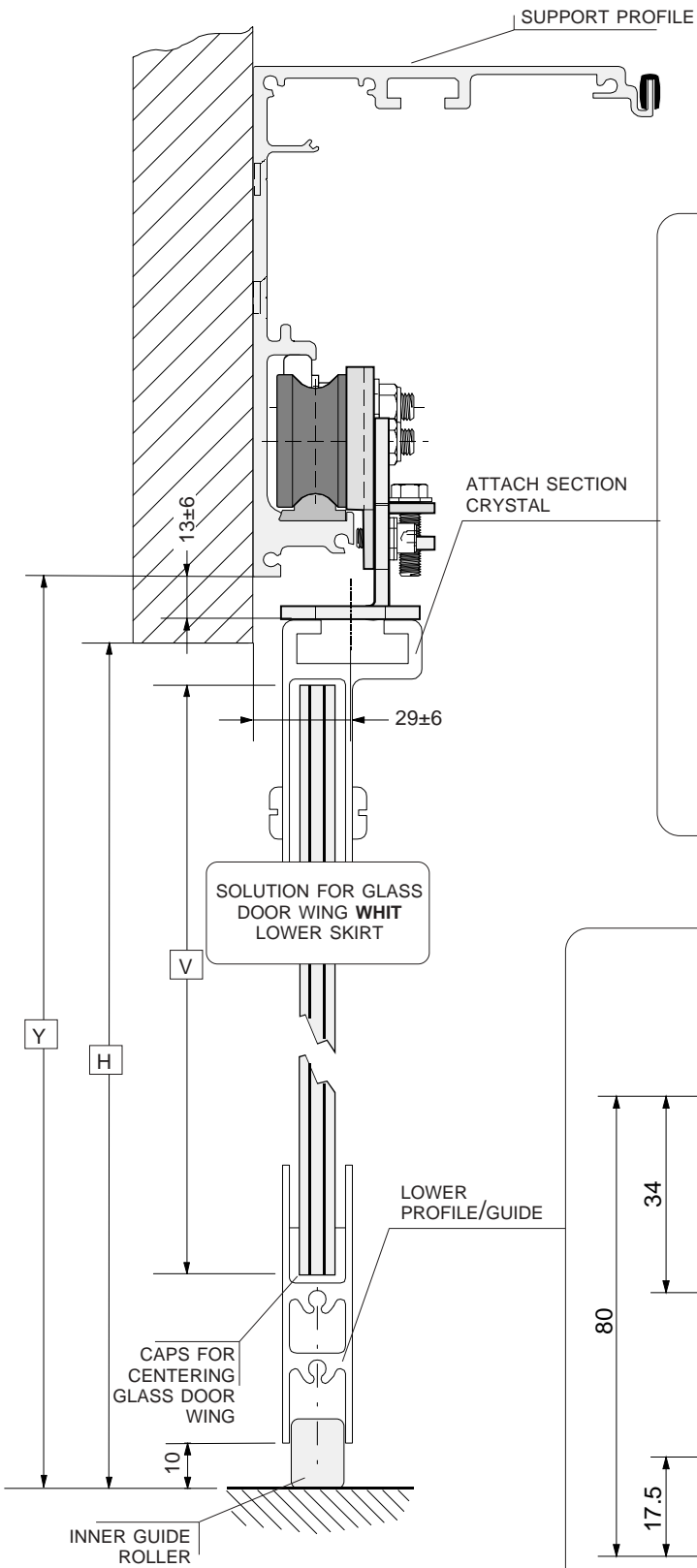

SOLUTION FOR GLASS DOOR WING **WHIT** LOWER SKIRT

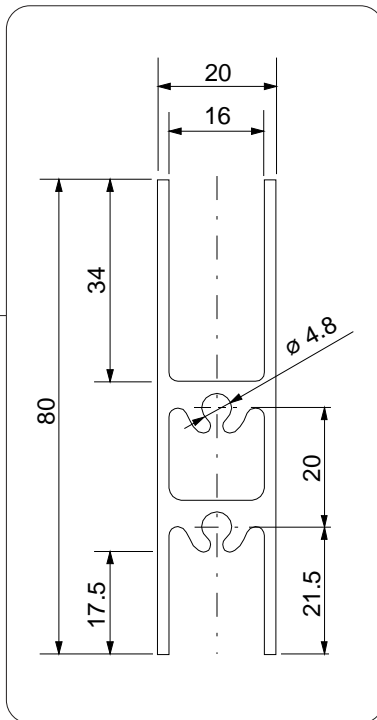
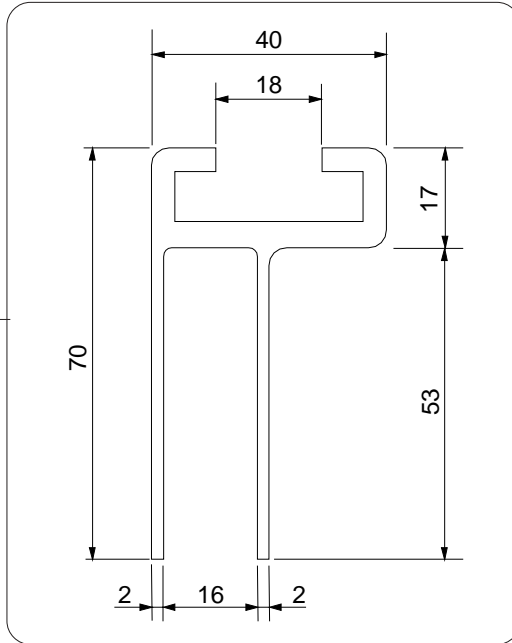

SOLUTION FOR GLASS DOOR WING **WITHOUT** LOWER SKIRT

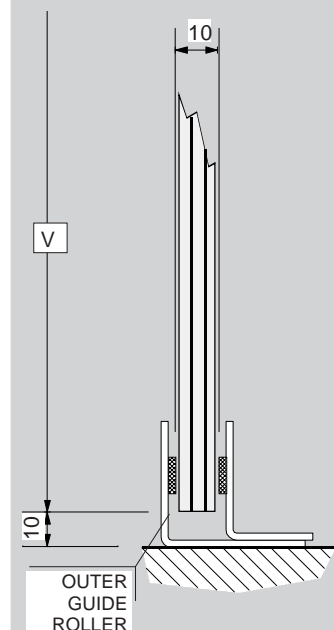

**V** =  
**H** - 70 mm  
**Y** - 88 mm

**V** =  
**H** - 22 mm  
**Y** - 40 mm

# DIAGRAMS OF GLASS DOOR WINGS

## GLASS DOOR WING(S) WITH LOWER SKIRT

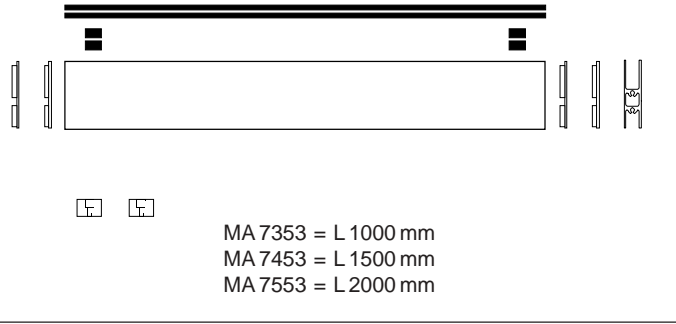
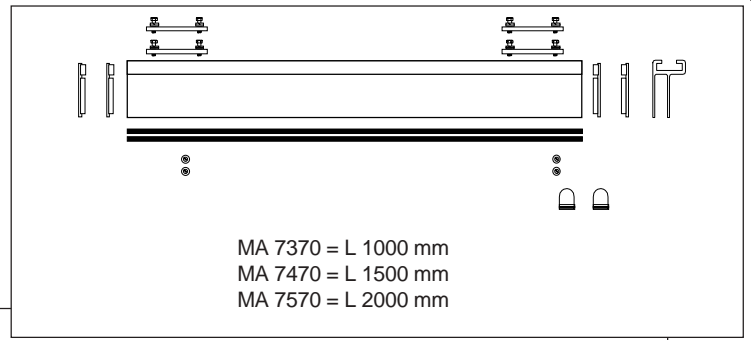
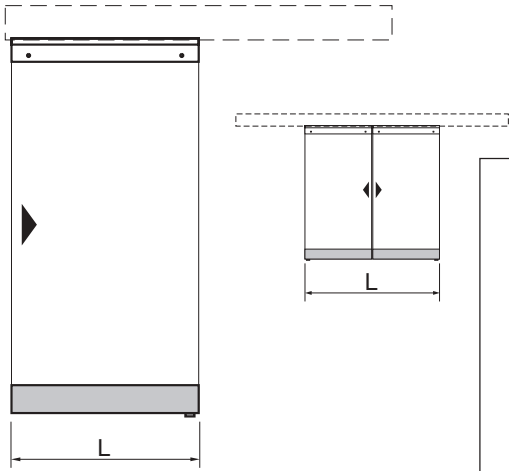

## DRILL POINTS FOR INSTALLING THE UPPER GLASS PANEL AND BEAMBEAM

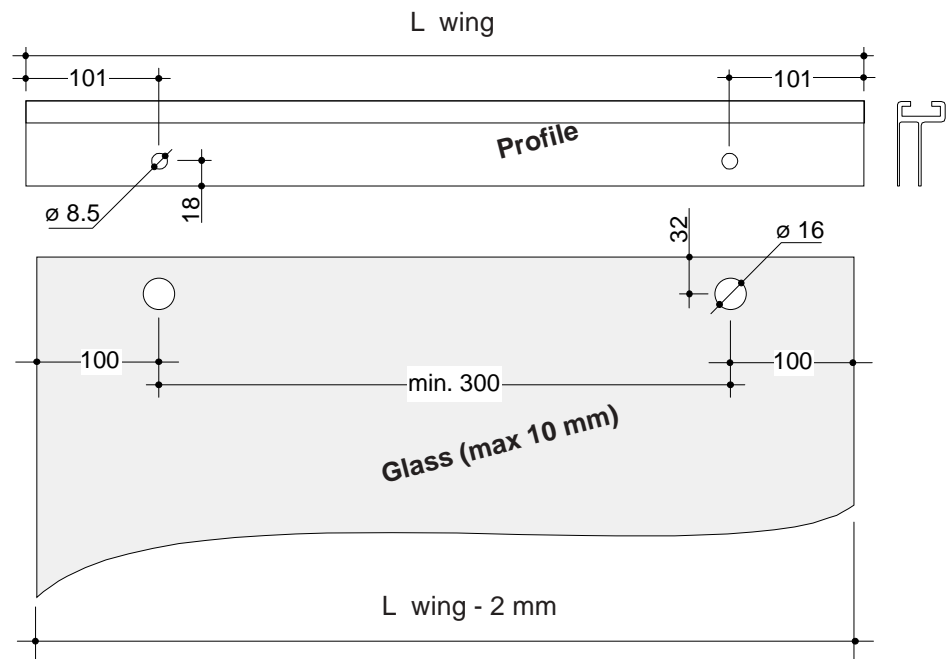

## GLASS DOOR WING(S) WITHOUT LOWER SKIRT

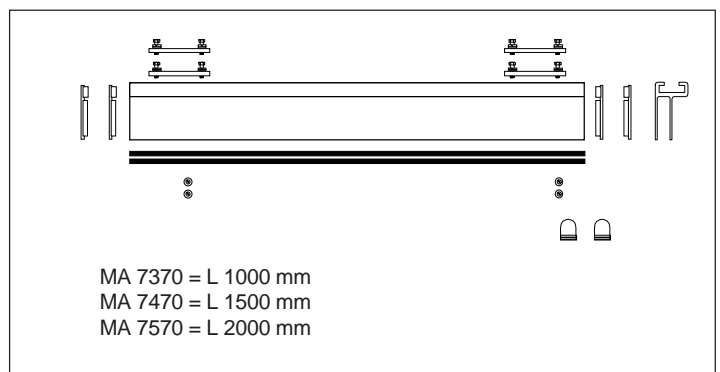
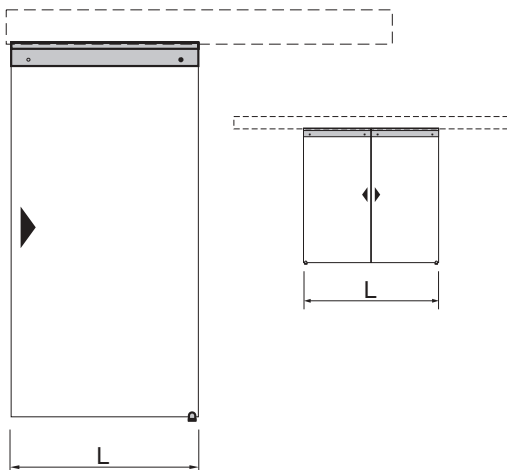

# DIAGRAMS OF DOOR WINGS WITH FRAME

**Y** = height at which beam is mounted  
=  $H + 18 \text{ mm}$

**H** = working height of passage

**I** = height of door wing with frame

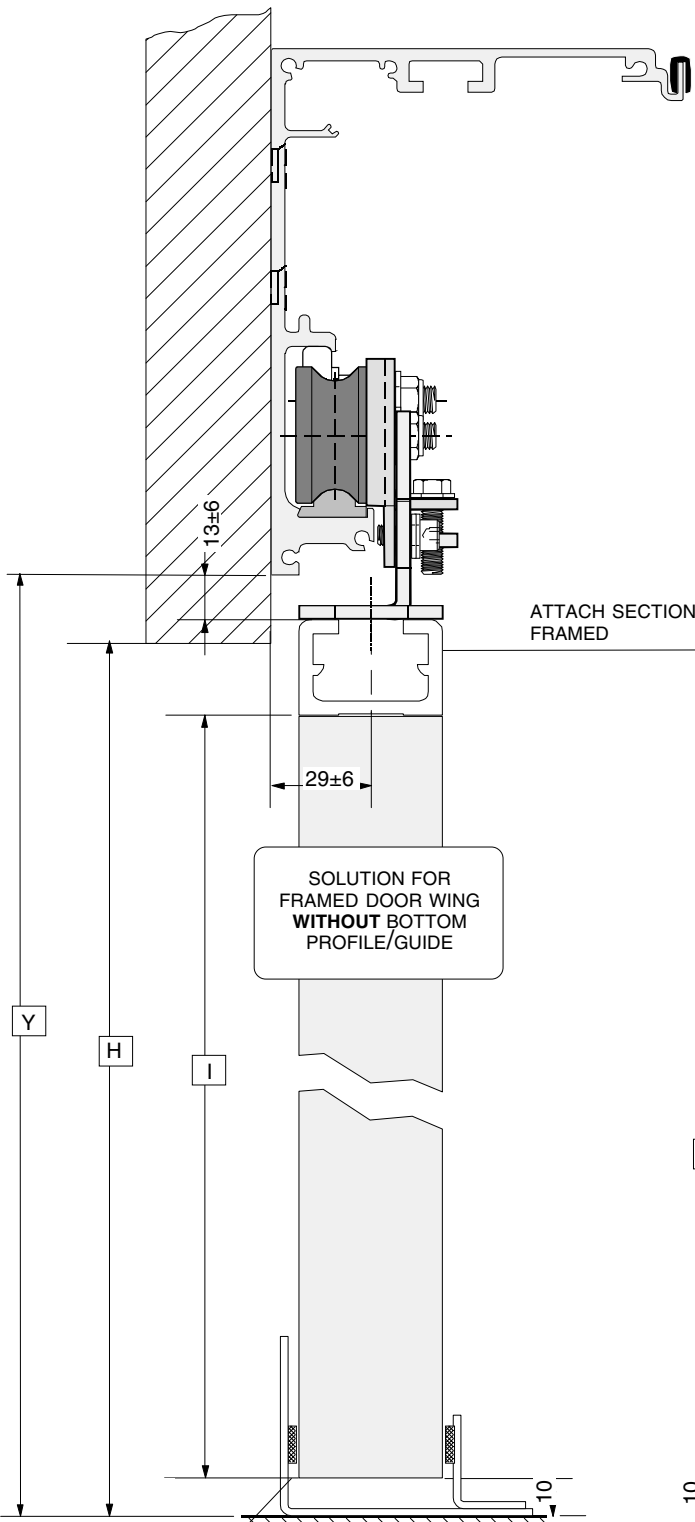

ATTACH SECTION FRAMED

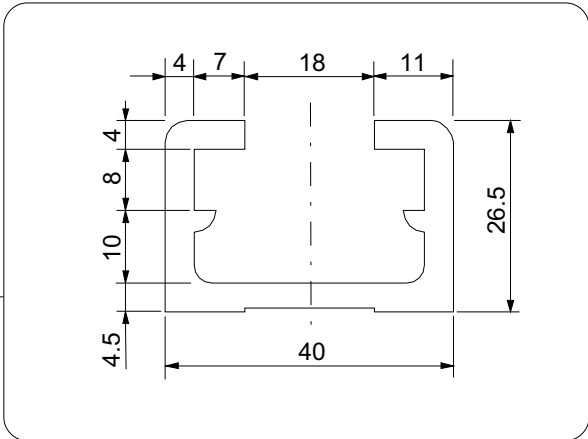

SOLUTION FOR FRAMED DOOR WING **WITHOUT** BOTTOM PROFILE/GUIDE

SOLUTION FOR FRAMED DOOR WING WITH BOTTOM PROFILE/GUIDE INSTALLED **EXTERNALLY**

SOLUTION FOR FRAMED DOOR WING WITH BOTTOM PROFILE/GUIDE INSTALLED **INTERNALLY**

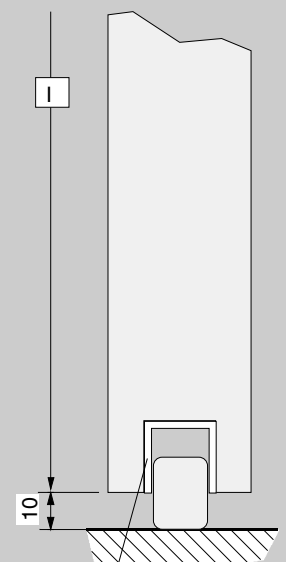
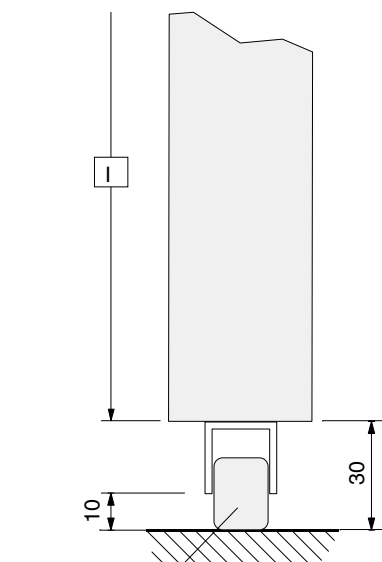

OUTER GUIDE ROLLER

**I** =  
**H** - 28 mm  
**Y** - 46 mm

INNER GUIDE ROLLER

**I** =  
**H** - 48 mm  
**Y** - 66 mm

**I** =  
**H** - 28 mm  
**Y** - 46 mm

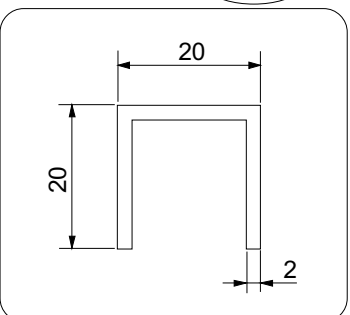

LOWER PROFILE/GUIDE

**DIAGRAMS OF DOOR WINGS WITH FRAME**

**DOOR WING(S) WITH FRAME, WITHOUT LOWER GUIDE PROFILE**

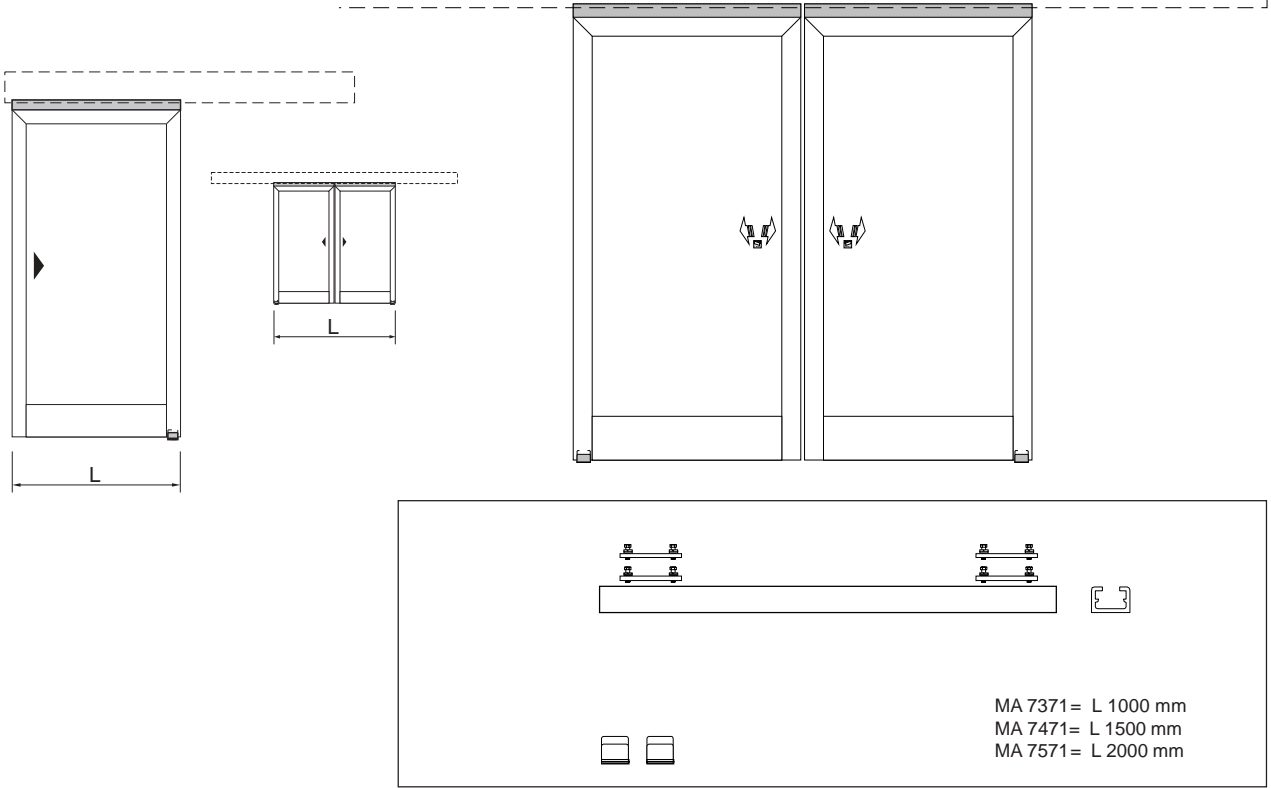

**DOOR WING(S) WITH FRAME, WITH LOWER GUIDE PROFILE**

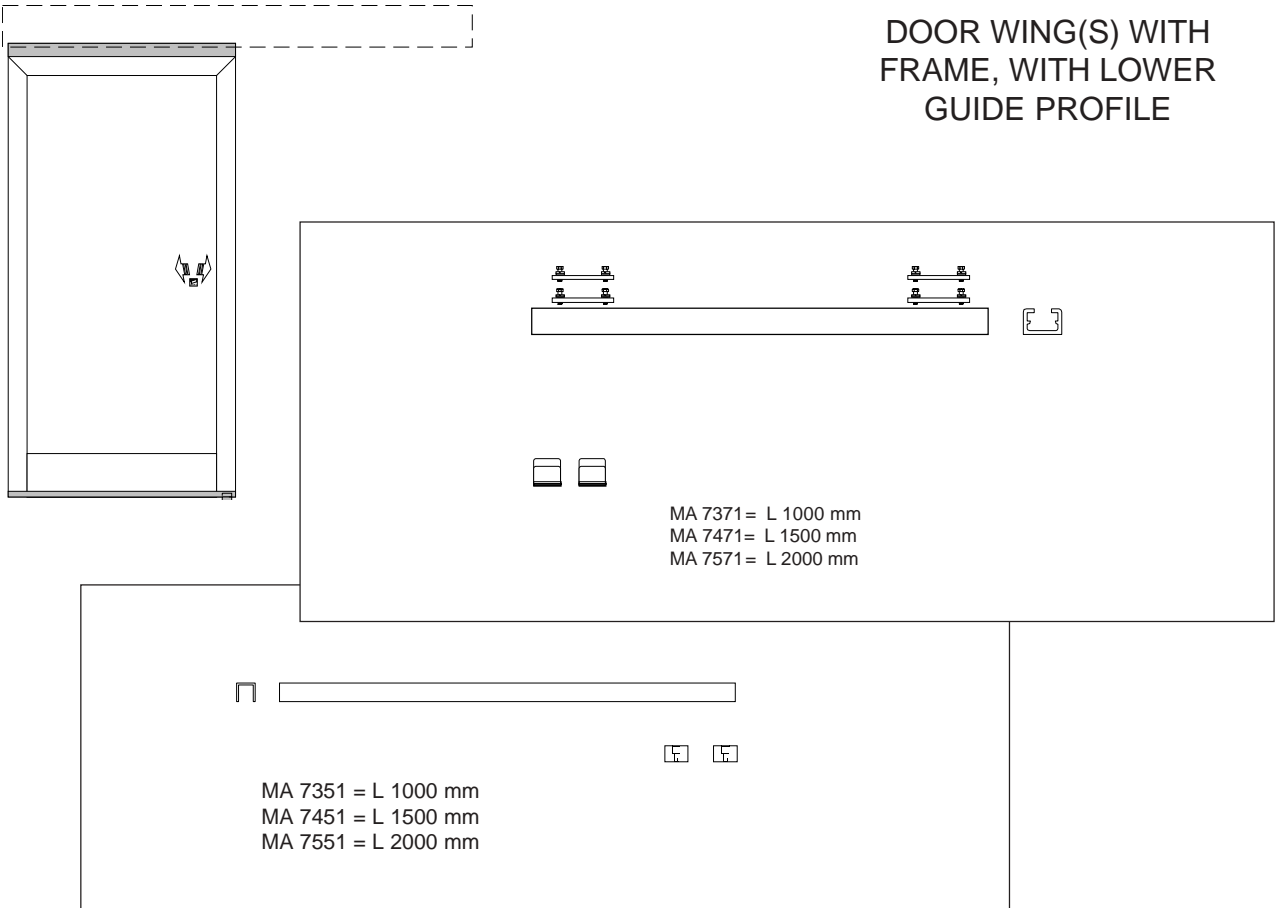

## INSTALLING THE BEAM

- 1) Remove the profile housing (optional at extra cost), if present
- 2) Remove the trolleys from the support profile by proceeding as follows:

**2 a)** Loosen the mounting screws to disconnect the trolleys (which are engaged by the belt) from the connecting bracket;

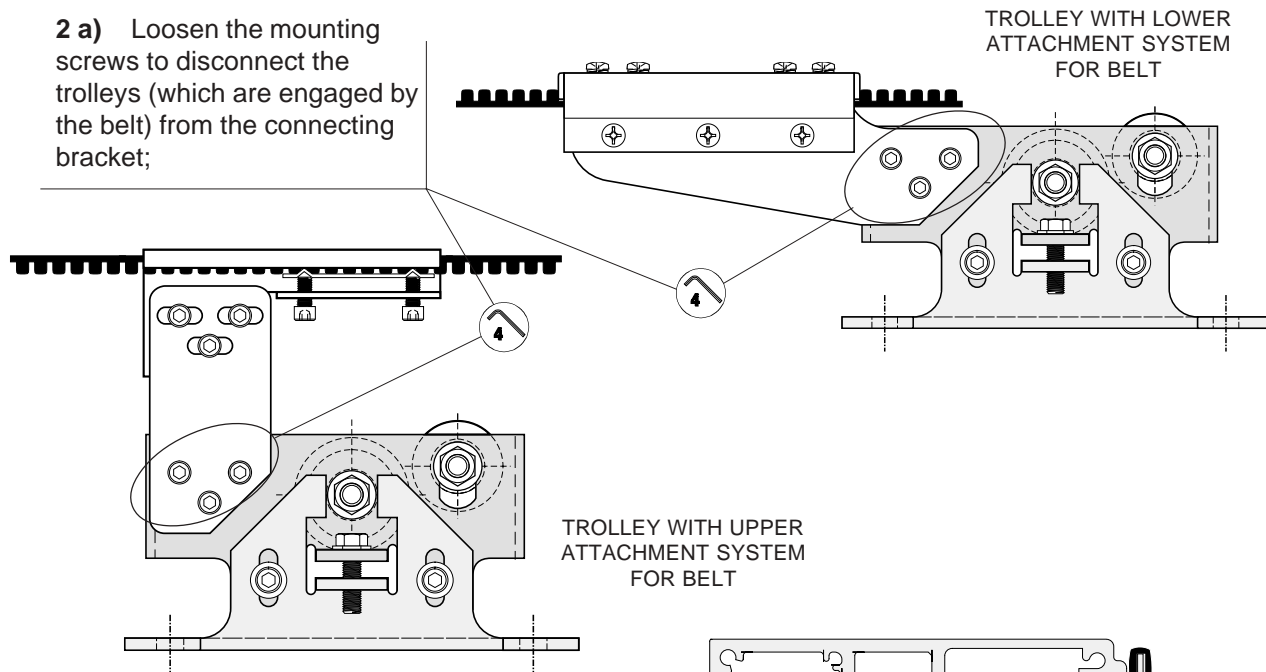

**2 c)** Raise the trolleys as required for removal from the guide track;

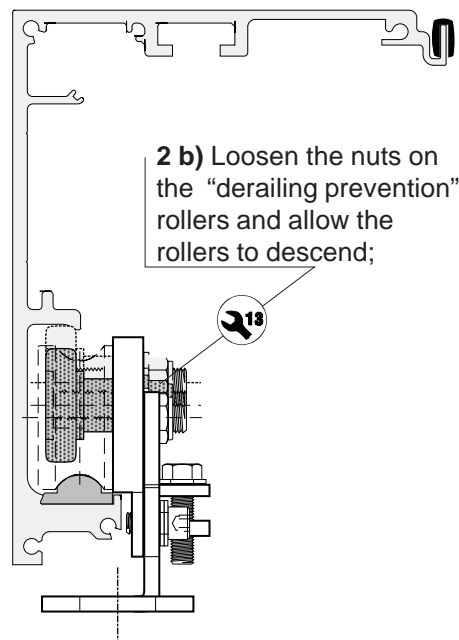

**2 b)** Loosen the nuts on the “derailing prevention” rollers and allow the rollers to descend;

- 3) Drill holes in the profile to allow passage of the power cables and sensor leads (photocells-radar);
- 4) Centre the automation system with the passage area;
- 5) Using the holes provided, fasten the automation system to the structure and check the system for correct horizontal alignment (levelling).

# INSTALLING THE DOOR WINGS

1) Fasten the trolleys to the door wings by proceeding as follows:

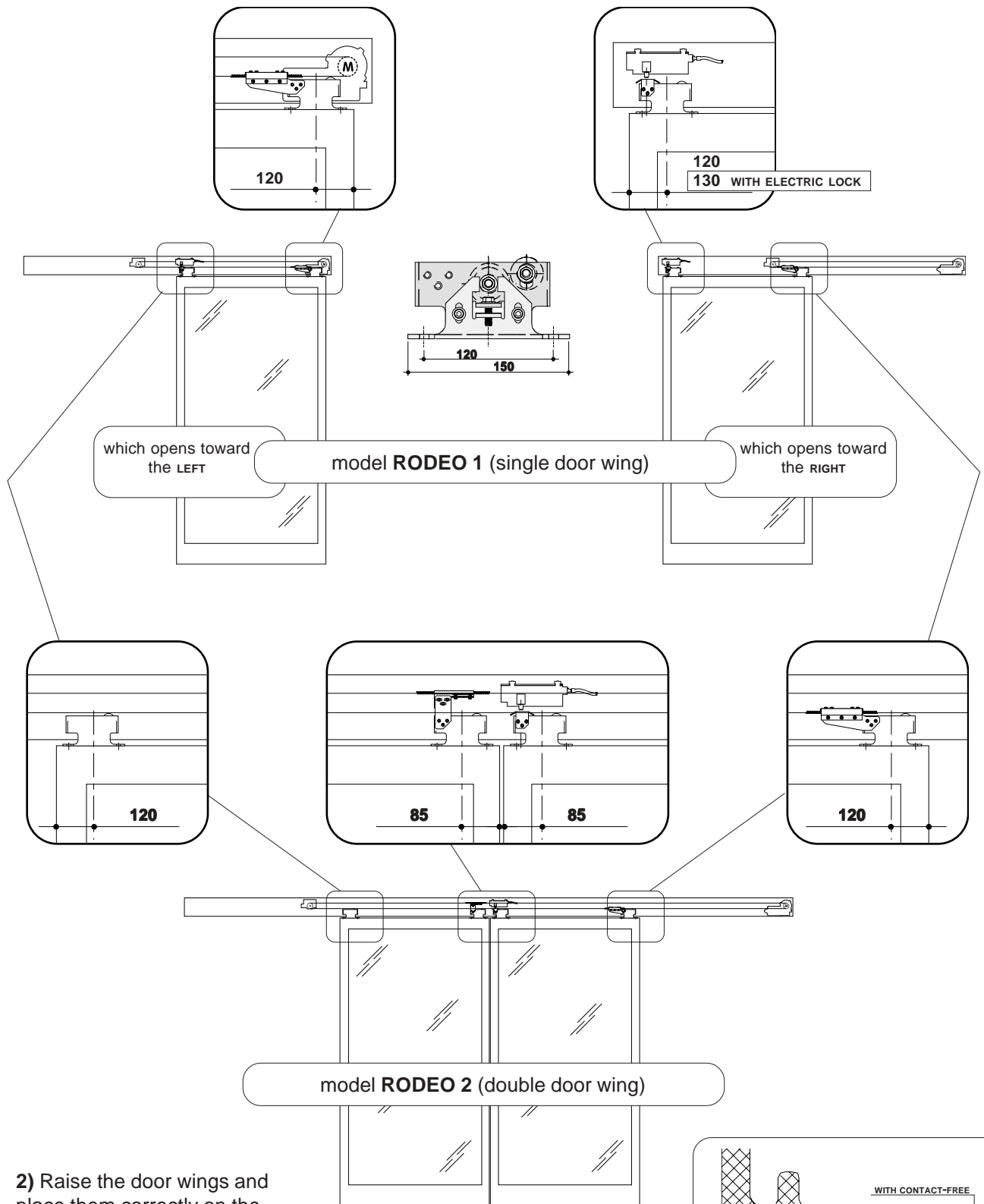

2) Raise the door wings and place them correctly on the guide track;

3) Lift and fasten the derailing prevention rollers without forcing them against the profile;

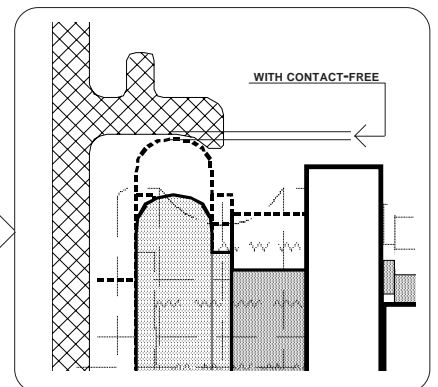

4) Re-connect the trolleys to their belt attachment systems;

# MECHANICAL ADJUSTMENTS

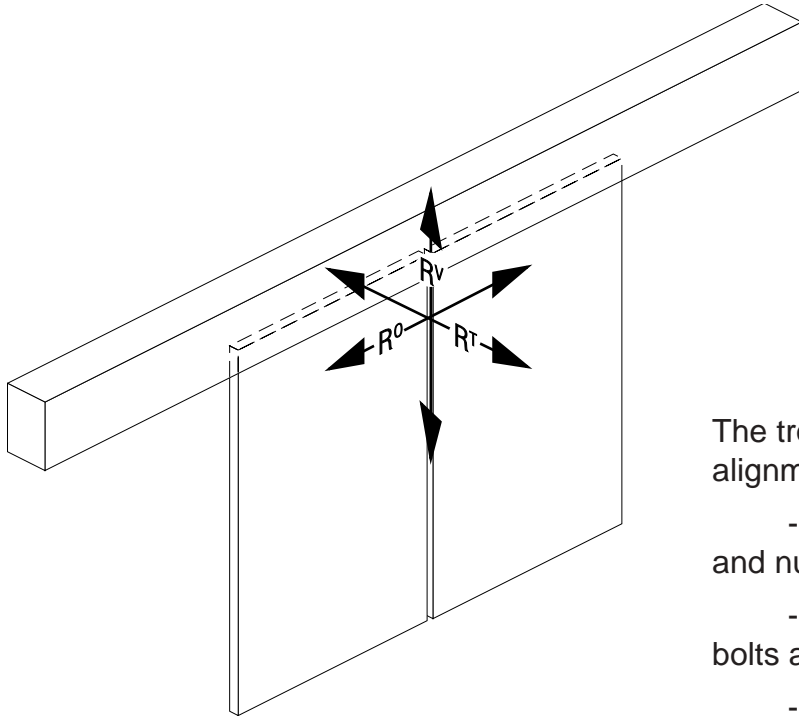

The trolleys can be used to adjust the alignment of the door wings as follows:

- **vertical** adjustment  $R^V$ , with bolts and nuts **A** and **B**
- **transverse** adjustment  $R^T$ , with bolts and nuts **C**
- **horizontal** adjustment  $R^0$ , with bolts and nuts **D** and **E**

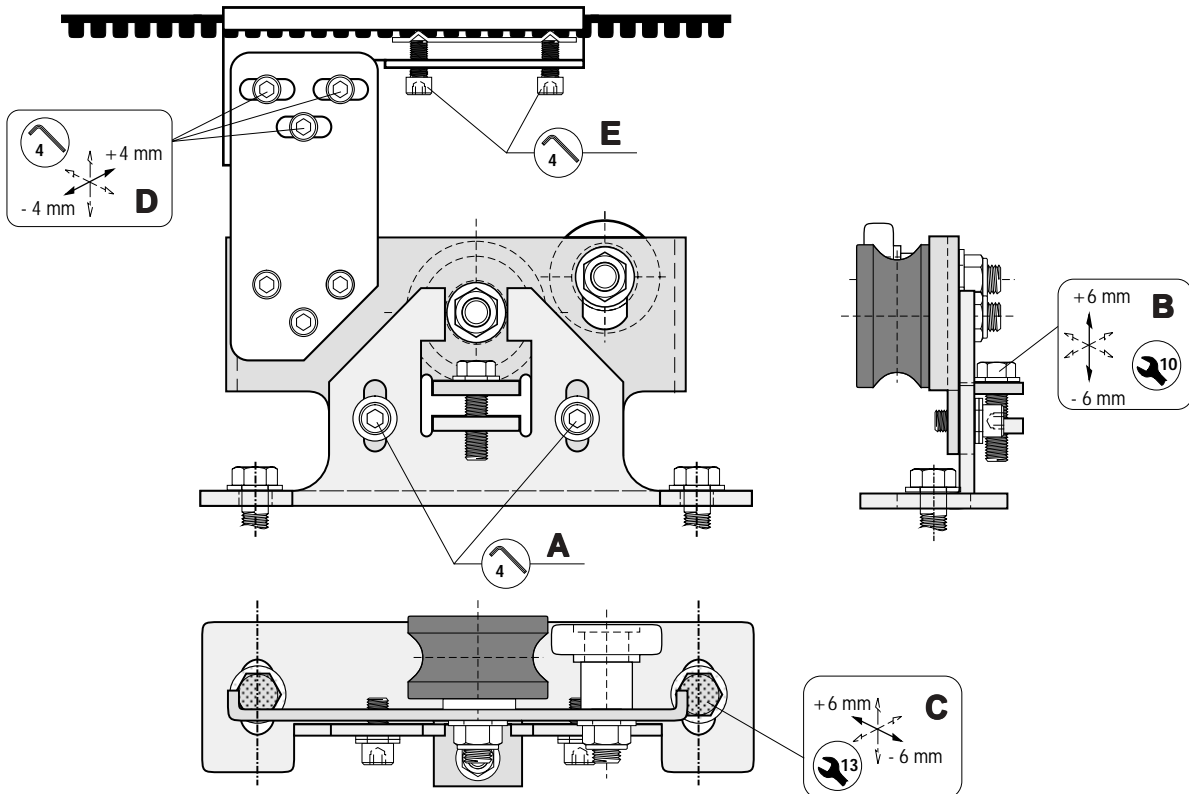

## MECHANICAL ADJUSTMENTS

### VERTICAL ADJUSTMENT R<sup>V</sup>

To obtain correct vertical alignment of the door wings, adjust the trolleys as follows :

- Loosen screws **A**.
- Turn vertical adjustment screw **B** until the door wing(s) is/ are as perpendicular to the ground as possible. If the automation system is being used to power two sliding door wings, adjust this screw so that no gap is left between the door wings when they are closed.
- After completing the adjustments, tighten screws **A** and move the door wing manually to make sure that there is no mechanical interference between the moving door wing(s) and the pavement along the entire line of movement.

If necessary, the entire door wing can be raised by adjusting both trolleys.

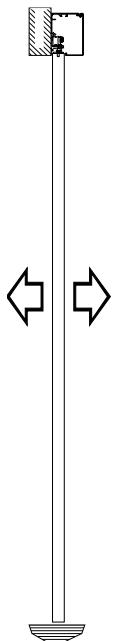
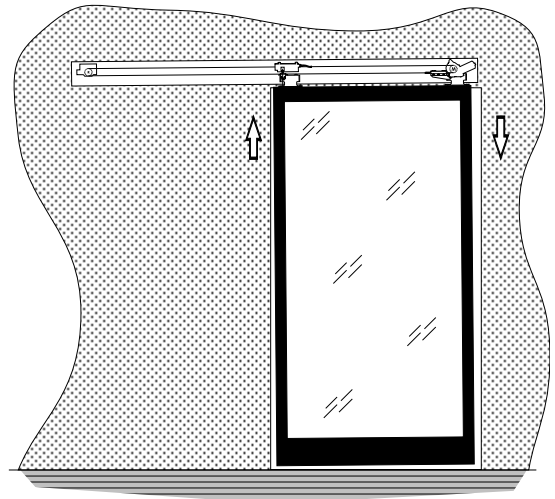

### TRANSVERSE ADJUSTMENT R<sup>T</sup>

The vertical plane of the rollers on the trolleys must be parallel with the beam. If the trolleys are out of alignment (i.e., if the door wing does not slide easily), proceed as follows:

- Loosen nuts and bolts **C**;
- Align the trolleys with the guide track (for example, by measuring distance **Q** between the body of the trolley and the beam);
- Move the door wing manually to make sure that there is no mechanical interference between the moving door wing(s) and non-moving parts/door wings along the entire line of movement.
- Tighten the bolts firmly to fasten the trolleys.

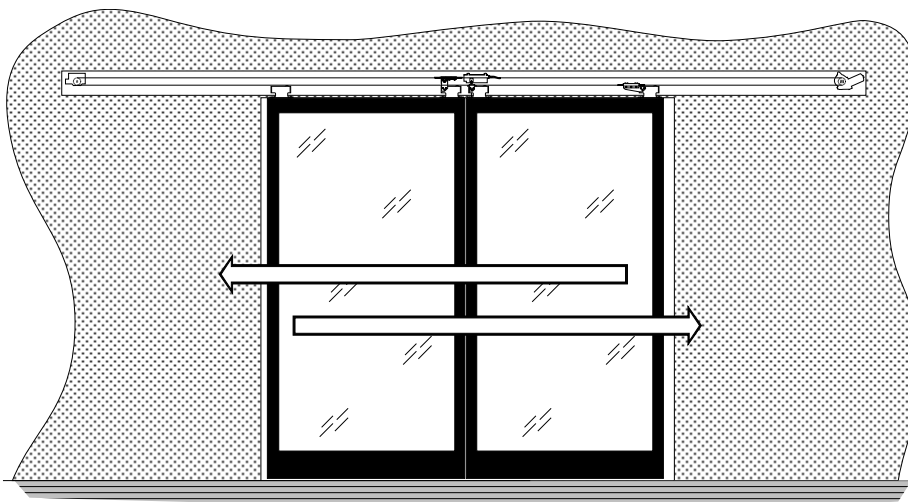
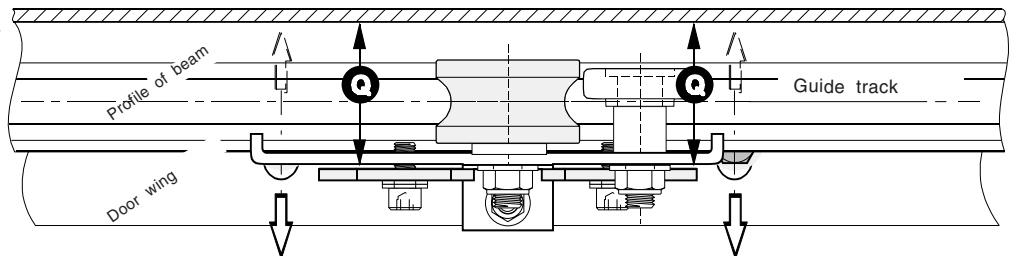
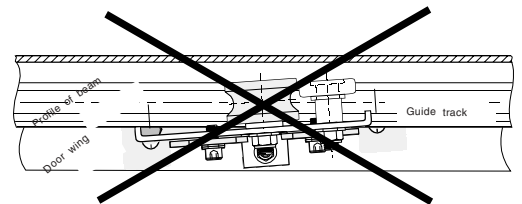

### HORIZONTAL ADJUSTMENT R<sup>O</sup> (for Rodeo 2, only)

For fine adjustment ( $\pm 4$  mm) of the point where the two door wings meet, loosen nuts and bolts **D** and move the two door wings at the same time.

To obtain a coarser adjustment, remove the belt attachment system by loosening nuts and bolts **E**.

After adjustment, tighten the bolts back down.

## MECHANICAL ADJUSTMENTS

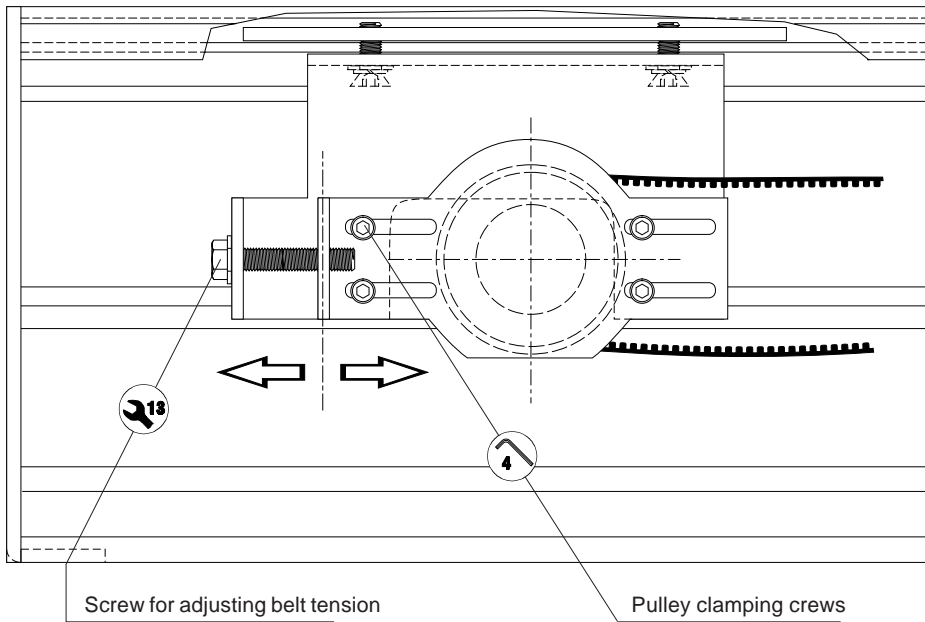

### ADJUSTING THE BELT TENSION

If necessary, the idle pulley can be used to adjust the tension on the belt. Proceed as follows:

- 1) Loosen the mounting screws on the pulley.
- 2) Rotate the adjustment screw until the correct belt tension is obtained.
- 3) Tighten the mounting screws carefully to maintain the correct tension.

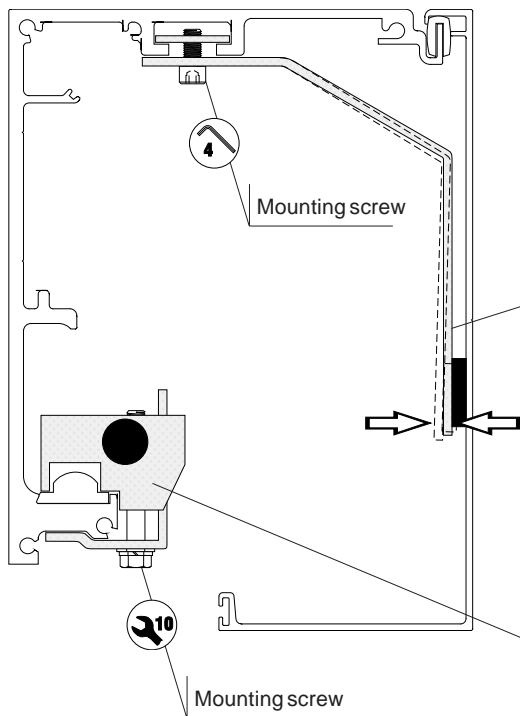

### ANTI-VIBRATION BRACKET ON THE PROFILE HOUSING

This bracket prevents the (optional) profile housing from oscillating and bending longitudinally. One bracket can be installed when the beam is mounted at a height of up to 2.80 m, while both brackets should be installed if beam height exceeds 2.80 m. If necessary, the bracket may be bent into the required shape.

### ADJUSTING THE MECHANICAL STOPS

The mechanical stops are used to set and adjust the opening width of the door wings so that they do not move beyond the ends of their travel. Loosen the mounting screws and move these stops to the proper positions.

**N.B.:** The mechanical stops must be correctly placed and tightened to prevent damage to the guide track and permit its adjustment.

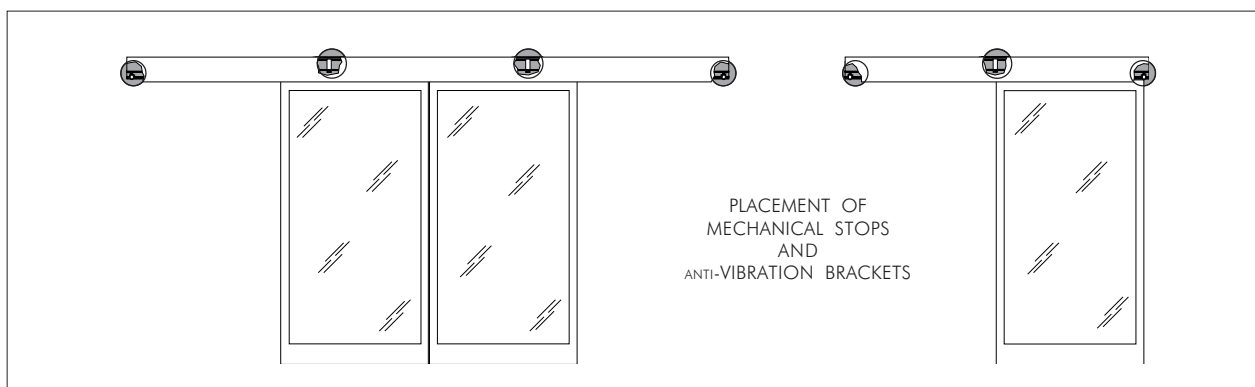

## MECHANICAL ADJUSTMENTS

### BELT SUPPORT

The belt support is used to control belt vibration. It is installed at the centre of automation systems powering two door wings whose support profile exceeds 3020 mm in length. If necessary, the support may be bent into the required shape.

**N.B.** Make sure that the belt support does not come into contact with moving parts during operation.

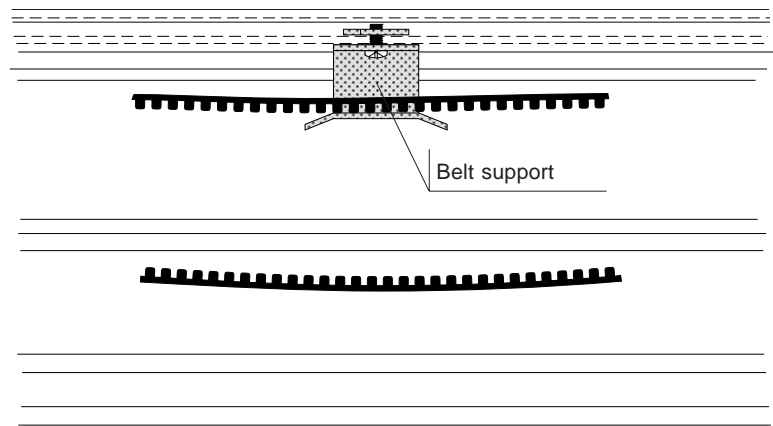
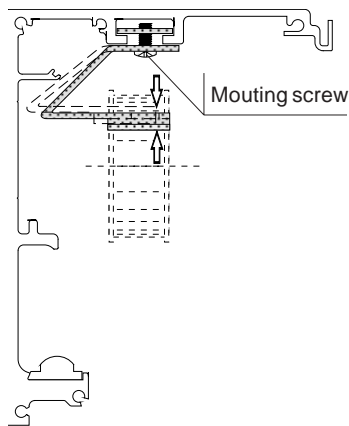

### CHECKING FOR PROPER ASSEMBLY

After the beam has been installed and all mechanical adjustments have been made, make sure that:

- \_ no scraps of materials left by manufacturing processes remain on the guide track, which would damage the track and/or the trolley wheels;
- \_ no foreign objects and/or tools have been left on the inside of the beam;
- \_ the door wings are properly aligned and the mechanical stops have been correctly positioned as described above.

Before applying power to the automation system, check for proper operation by opening and closing the system manually (push directly on the door wings to perform this check).

# ZP8 ELECTRICAL CABINET

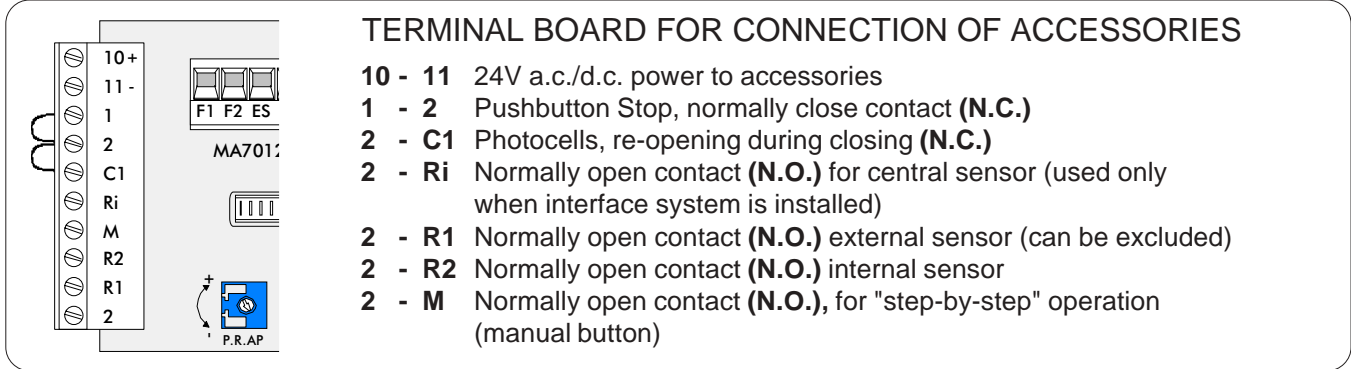
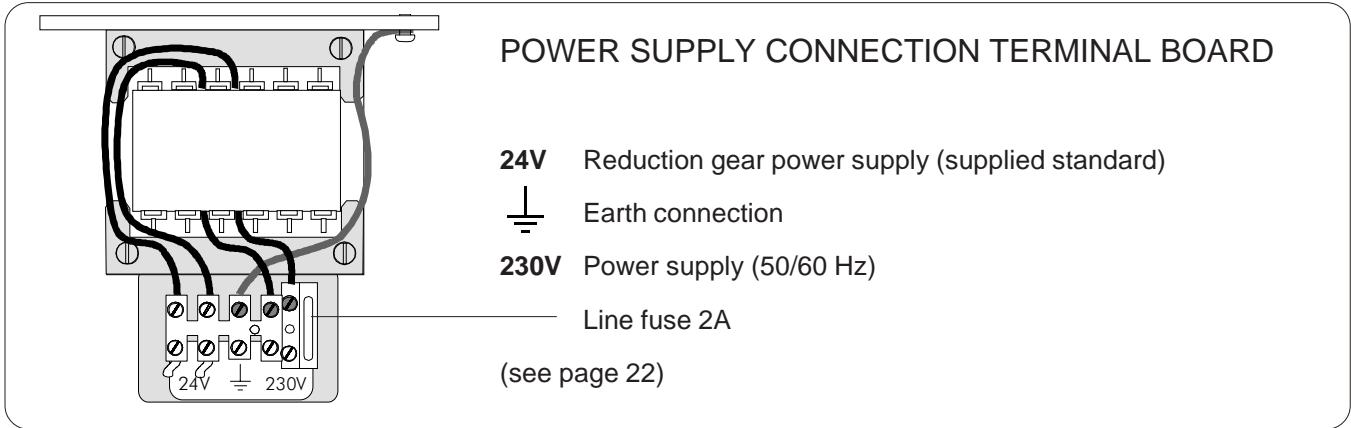
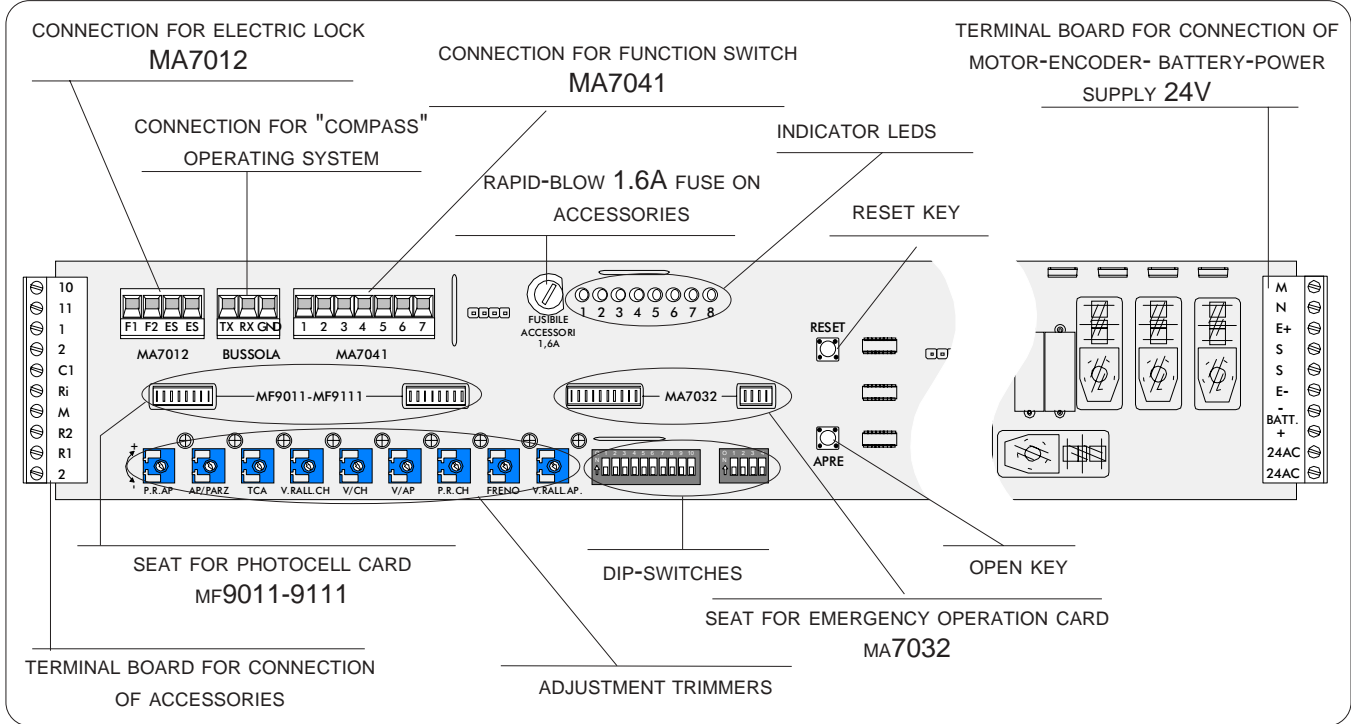

- **Contact 1-2 and 2-C1** are normally closed (N.C.) and bridged together at the factory. To use these functions, replace the bridge connections with the relative devices.

- The **2-C1 contact** is used when a security system is desired (for example, photoelectric cells or other control devices), which is not capable of being housed in the special clip-in seat. **Note:** if the MA9011/9111 photoelectric cell card is not enabled, or if it is enabled and you wish to disable it, set dip switch 3 to ON (4-way module).

- The **2-M contact** is normally open (N.O.), and has a double function:

- 1) During normal functioning it is enabled for opening, even if the MA7041 function selector is set on "doors closed". This function can be used for preferential passage, (e.g., evening closure, opening command on key or magnetic switches).
- 2) By setting dip switch 5 to ON (10-way module), the "stepper" opening function is enabled (by pressing the button the door opens; pressing it again closes the door). **Attention**, by using this function contacts 2-R1 and 2-R2 are excluded.

## ZP8 ELECTRICAL CABINET

**RESET** — The **RESET** key, resets the data and restarts the automation in question.

**APRE** — The **APRE** key, starts automation and completes an opening cycle. **Attention:** The function of the open key is excluded if dip switch 5 (10-way module) is set to ON.

**IMPORTANT:**

Do not perform the following operations, electrical connections/wiring or replacement of circuit cards unless the mains power has been disconnected and the “+” (red) power terminal has been removed from the emergency battery (if installed).

## ADJUSTMENT TRIMMERS

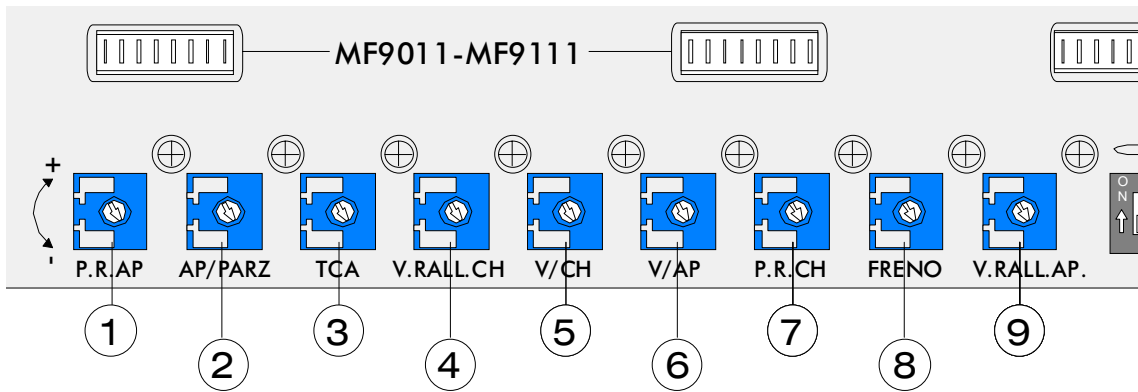

ADJUSTMENTS TRIMMERS											
N°	1	2	3	4	5	6	7	8	9		
<b>FUNCTION</b>	START POINT OF OPENING SLOWDOWN	PARTIAL OPENING	AUTOMATIC CLOSING	SLOWDOWN CLOSING	CLOSING SPEED		OPENING SPEED		START POINT OF CLOSING SLOWDOWN	BRAKING INTENSITY IN THE INITIAL SLOWDOWN PHASE	SLOWDOWN OPENING
<b>VALUE</b>	STARTING POINT	60 ÷ 90 %	0.5 ÷ 13 SEC.	5 ÷ 12 CM/SEC.	RODEO 1 8,6 ÷ 55 CM/SEC.	RODEO 2 17,2 ÷ 78 CM/SEC.	CORSA 1 8,6 ÷ 55 CM/SEC.	CORSA 2 17,2 ÷ 78 CM/SEC.	STARTING POINT	.....	5 ÷ 12 CM/SEC.

## SELECTION FUNCTIONS

Dip 10-way		SELECTION FUNCTIONS
1	ON	Parameter storage (used during calibration pag. 17).
2	ON	Checking the charge level on the emergency (whit MA7032, see pag.18).
3	-	Not used, keep the dip in position «OFF».
4	ON	Constant push while closing
5	ON	"Step-by-step" operation (see contact 2-M, pag.14).
6	ON	Interface with other automation system (see "installing the interface system" pag.20).
7/8	ON	Disabled electric lock (see pag.19).
7	ON	Continuous operation of lock (locks doors open and closed) see pag.19
8	OFF	
7	OFF	Continuous operation of lock (locks doors closed) see pag.19
8	ON	
7/8	OFF	Electric lock disengaged from local control (controlled by function switch MA7041) pag.19
9/10	ON	Emergency system closes doors in case of power failure (see pag.18)
9	OFF	Emergency system opens doors in case of power failure (see pag.18)
10	ON	
9/10	OFF	Normal operation powered by emergency battery in case of power failure (see pag.18)

Dip 4-way		SELECTION FUNCTIONS
1	ON	Activation of spring-loaded anti-panic device (set dip switch 4 to ON, constant push while closing, 10-dip function selector, see pag.19).
2	-	Not used, keep the dip in position «OFF»
3	ON	Excludes the photoelectric cell function (MF9011 or MF9111 card inserted into the control board, pag.22)
4	-	Not used, keep the dip in position «OFF»

## FUNCTIONS OF INDICATOR LED

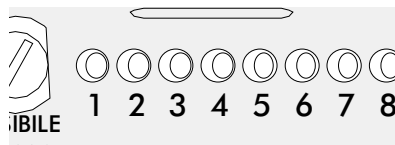

LED	STATUS	SIGNAL
1	flashing	-Encoder is inoperative
1	lit	-Encoder is inoperative
2	(*)	-emergency battery is discharged
3	lit	-pilot light on 24V a.c.
4	lit	-photocell contact open
5	lit	-interface function activated (see "installing the interface")
6	lit	-malfunction on electric lock
7	lit	-pilot light on amperometric sensor
8	flashing	-automatic closing cycle in progress
8	flashing	-"read" error during automatic calibration cycle
6/7/8	lits	-automatic calibration procedure terminated

(\*) in this case, the LED signal **remains lit** to indicate that the anti-panic device batteries are run down only if the emergency battery status check is **disabled** (10-way dip 2 set to OFF); whereas it **flashes** if the battery check is **activated** (10-way dip 2 set to ON).

## STARTING UP THE SYSTEM

### VERIFICHE PRELIMINARI

Before start-up, make sure that:

- ✓ The electric lock (if installed) has been manually released;
- ✓ The proper tension has been applied to the belt (see p. 12);
- ✓ The checks described on p. 13 (checking for proper assembly) have been performed;
- ✓ No objects are present along the path taken by the door wings as they move;
- ✓ All mounting hardware has been properly tightened;
- ✓ The sensors are correctly aligned and are not blocked;
- ✓ The desired functions have been correctly selected on the dip switches (see p. 16);
- ✓ The trimmers have been set to their midpoints (see p. 15),

### START-UP/CALIBRATION

1. Turn on the power to the unit
  - LED no. 3 will light up
2. Move dip switch 1 to ON
  - LED no. 3 will turn off and LED no. 8 will light up
  - The system will execute a closing and opening cycle at reduced speed and will stop at the maximum open position <sup>(1)</sup> at the end of the cycle
  - LEDs no. 6-7-8 will light up
3. Move dip switch 1 to OFF
  - LEDs no. 6-7-8 will turn off and LED no. 3 will light up
4. Make sure that function switch MA7041 (if installed) has been set to the "open" position (with the LEDs lit in sequence)
5. Enter an "open" command on 2-R1/2-R2 or by pressing the open key (see p.15).
  - the automation will position itself at the closing point
6. Send an opening signal
  - the automation will perform a complete manoeuvre
7. Adjust the movement of the doors using the door trimmers (see p.15).
8. Adjust trimmer 3 to obtain the desired delay before automatic closing
9. Trimmer 2 can be adjusted only if function switch MA7041 has been installed and if this switch has been set to the "partial opening" position
10. Use the lever on the manual release system to re-arm the electric lock (if installed)

<sup>(1)</sup> If the automation system stops during the closing cycle, the motor polarity may be incorrect. If this occurs, proceed as follows:

- Disconnect the mains power
- Make sure dip switch 1 is set to OFF
- Reverse connections M-N on the terminal board for the motor, which is located in the electrical cabinet (on the right)
- Begin another start-up/calibration procedure starting from point 1.

### SAFETY FUNCTIONS - Actions taken by the automation system when a safety device trips

When the safety sensor detects an obstacle, the microprocessor control system in the electrical cabinet actuates:

- |                    |                                                                                                                  |
|--------------------|------------------------------------------------------------------------------------------------------------------|
| <b>re-opening,</b> | if the automation system is closing;                                                                             |
| <b>a stop,</b>     | if the automation system is opening. The system will then re-close when actuated by the automatic closing timer. |

If the obstacle is still detected:

- |                       |                                                                                                                                                                                                                                                                                            |
|-----------------------|--------------------------------------------------------------------------------------------------------------------------------------------------------------------------------------------------------------------------------------------------------------------------------------------|
| during <b>closing</b> | the automation will automatically try 4 times to close the doors, and then it will stop them in the open position, awaiting a new command.                                                                                                                                                 |
| during <b>opening</b> | the automation system will stop with the door wings resting against the obstacle and will re-close when actuated by the automatic closing timer. It repeats the checking operation at every opening command and resets with the following manoeuvre when the obstacle has been eliminated. |

(In both cases, normal operation with the programmed settings will automatically resume when the obstacle is removed)

### Changing the direction of door opening (Rodeo 1)

- With the door stopped, reverse connections M-N on the terminal board for the motor, which is located in the electrical cabinet (on the right);
- Re-align electric lock MA7012.
- Press the RESET key on the electrical cabinet (if the unit has already been calibrated, the relative settings will be deleted).
- Start up (or restart) the automation system as described in the section on start-up.

## INSTALLATION OF ACCESSORIES (available upon request)

### MA7032 - Battery-powered emergency system

This emergency system opens the door in case of power failure. It includes a pair of 12V (1.2Ah) batteries as well as a circuit card that keeps the batteries charged and distributes power to the automation system.

By using dip switches 9 and 10 (10-way module), the emergency system can be programmed to operate in the following ways when the power fails:

**Note:** When functioning is interlocked (see p. 20), the following functions are selected equally for both automations.



9 OFF  
10 ON

**Opening only.** The doors open and remain open until current returns to the line. The same occurs even if the MA7041 selector is set to "doors closed".

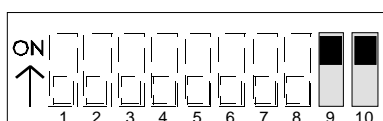

9 ON  
10 ON

**Closing only.** The doors close and stay closed (even if "door open" has been selected on MA7041) until the mains power is restored.

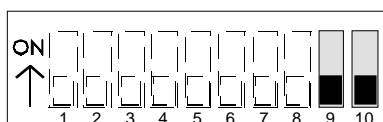

9 OFF  
10 OFF

**Normal functioning.** The doors continue to function until the current in the batteries drops below the safety level, in which case they stop. If the MA7041 function selector is set to "doors closed", the doors can only be opened by entering a command on the 2-M contact.

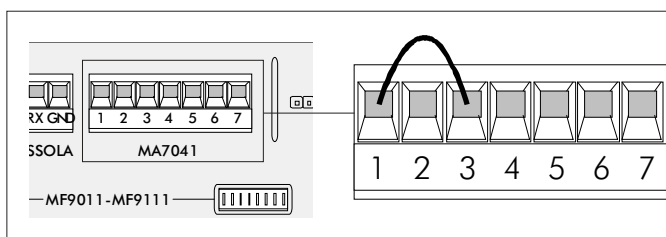

**Note:** in case the MA7041 selector is not connected and you wish to activate the antipanic function, bond contacts 1-3 as shown in the figure.

### Anti-panic device with constant battery control

Setting dip switch 2 of the 10-way module to the ON position (on the interlock system, set it on both panels) activates the **constant control of the battery charge buffer**, which during normal functioning with 230V power mains voltage checks the minimum charge of the 20V batteries; if it falls below this level (on the interlock system the voltage of the batteries of one of the two automations) the function activates a safety procedure. This procedure consists in the opening or closing of the doors (depending on the settings of dip switches 9 and 10). For the interlock system, the safety procedure (signalled by a continual flashing of LED No. 2 on the MASTER panel) causes the doors to open on both the automatic system. After reset of the batteries, the LED goes out and the system re-starts normally after an 'open' command.

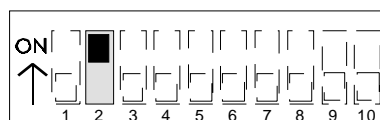

**N.B.:** For single automation installations, activating the battery control deactivates normal functioning (dip 9 OFF – 10 OFF).

- If function switch MA7041 is installed, make sure that the "EMERGENCY" function has been selected (which is indicated by a flashing yellow LED).
- In any event, normal operation with the programmed settings will automatically resume when the mains power is restored.

## INSTALLATION OF ACCESSORIES (available upon request)

### MA7012 - Electric lock

Electro-mechanical system for locking the door wings, with gravity-powered mechanical locking action and electric unlocking system. This device locks the door wing(s) in the closed position (and/or in the open position) by engaging a bracket installed on one of the trolleys.

By using dip switches 7 and 8 (10-way module), the electric lock can be programmed to operate as follows:

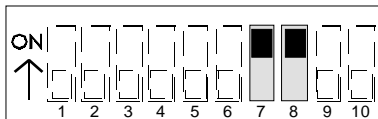

7 ON  
8 ON

**Deactivated.** Use this setting when the electric lock is not installed.

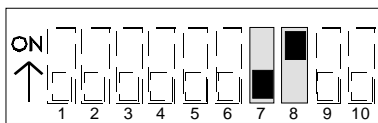

7 OFF  
8 ON

**Locking with doors closed.** This is normal operation: the unit locks on closure and is released electrically when the open command is given. This is the default setting.

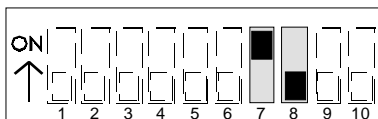

7 ON  
8 OFF

**Locking with doors closed and open.** The unit locks both when open and closed (when positioned correctly <sup>(1)</sup>), and is released electrically by each open and close command.

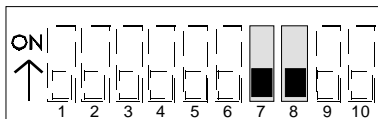

7 OFF  
8 OFF

**Delayed locking.** The electric lock is unlocked when the first "open" command is given at initial start-up or after a power failure, or when "door open" is selected on MA7041. The lock is locked when "door closed" or "output only" is selected on MA7041.

### MI1010 - Spring-loaded Anti-panic device

Mechanical device to open the doors, made up of a spring-loaded system which operates without electric power supply. With this device, use the dip-switches as indicated.

DIP SWITCH  
10-WAY

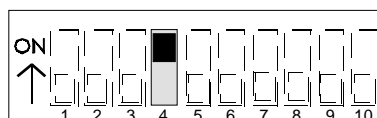

DIP SWITCH  
4-WAY

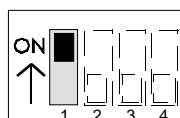

4 ON Activation of constant push while closing. (10-way dip switch)

1 ON Activation of spring-loaded anti-panic device. (4-way dip switch)

## INTERFACE FUNCTION

### DIAGRAM OF TWO INTERLOCKED AUTOMATION

- |                                        |                                   |
|----------------------------------------|-----------------------------------|
| ① 1 or 2 copies of photoelectric cells | ④ Electric lock <b>MA7012</b>     |
| ② Board ( <b>MA9011-MA9111</b> )       | ⑤ Radar ( <b>MR8002-MR8104</b> )  |
| ③ Anti-panic board <b>MA7032</b>       | ⑥ Function selector <b>MA7041</b> |

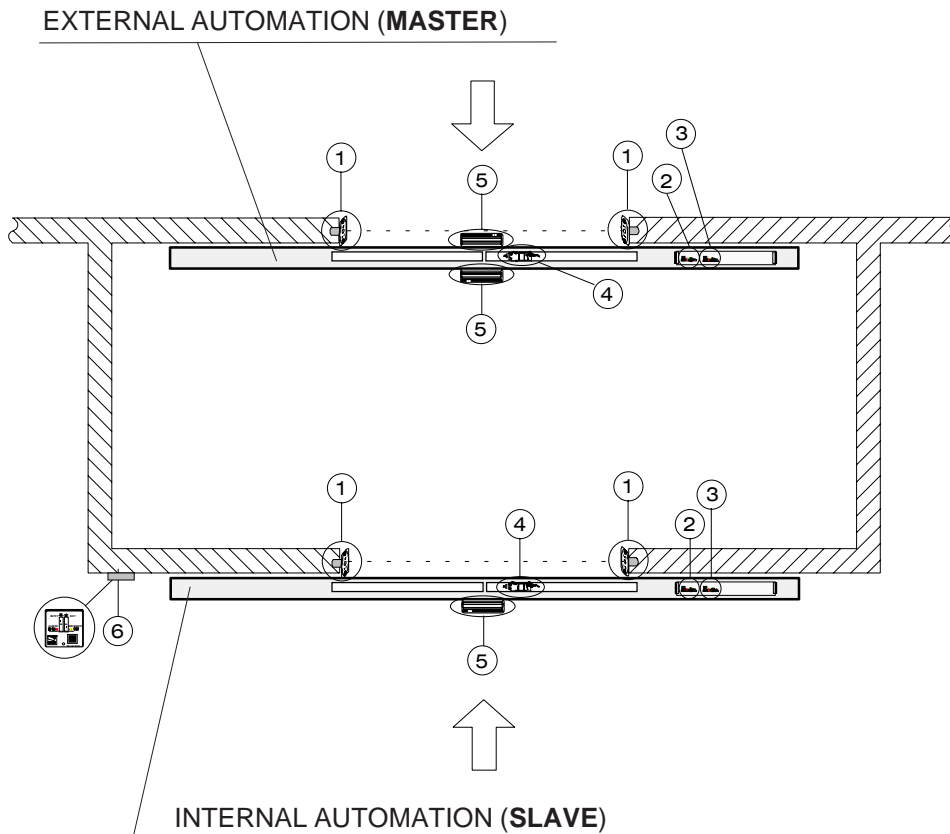

### Operation

When one of the radars is detected (internal or external), the automation opens the relative door and at the same time locks the other door, triggering a sequence of operations ending with the closing of the second door.

**STANDARD SEQUENCE:**

- DETECTION OF OBJECT BY **OUTER** OR **INNER** SENSOR
- OPENING OF **1<sup>ST</sup>** DOOR / DEACTIVATION OF OPPOSITE SENSOR
- CLOSING OF **1<sup>ST</sup>** DOOR
- OPENING OF **2<sup>ND</sup>** DOOR
- CLOSING OF **2<sup>ND</sup>** DOOR / ACTIVATION OF OPPOSITE SENSOR

The central sensor (intermediate) connected to clamps 2-RI detects the presence of persons between the two automations, and enables the microprocessor to reopen the automatic system opposite the one that was last opened, as always using the interlock function.

### Connections required

Connect the accessories to the two panels and to each other using the compass clamp (**bussola**) according to the illustrated diagram.

Set dip switch 6 on the **outer automation** system to ON, which will assign MASTER control status to that system.

All control sensors and function switch MA7041 (if installed) must be connected to the MASTER automation system, which controls the other automation system.

The photoelectric cells and the anti-panic device must be independent on both automations.

The trimmer adjustments on the two automation system act independently.

If contacts 1-2 and 2-C1 are not used, they must be connected by jumpers on both automations.

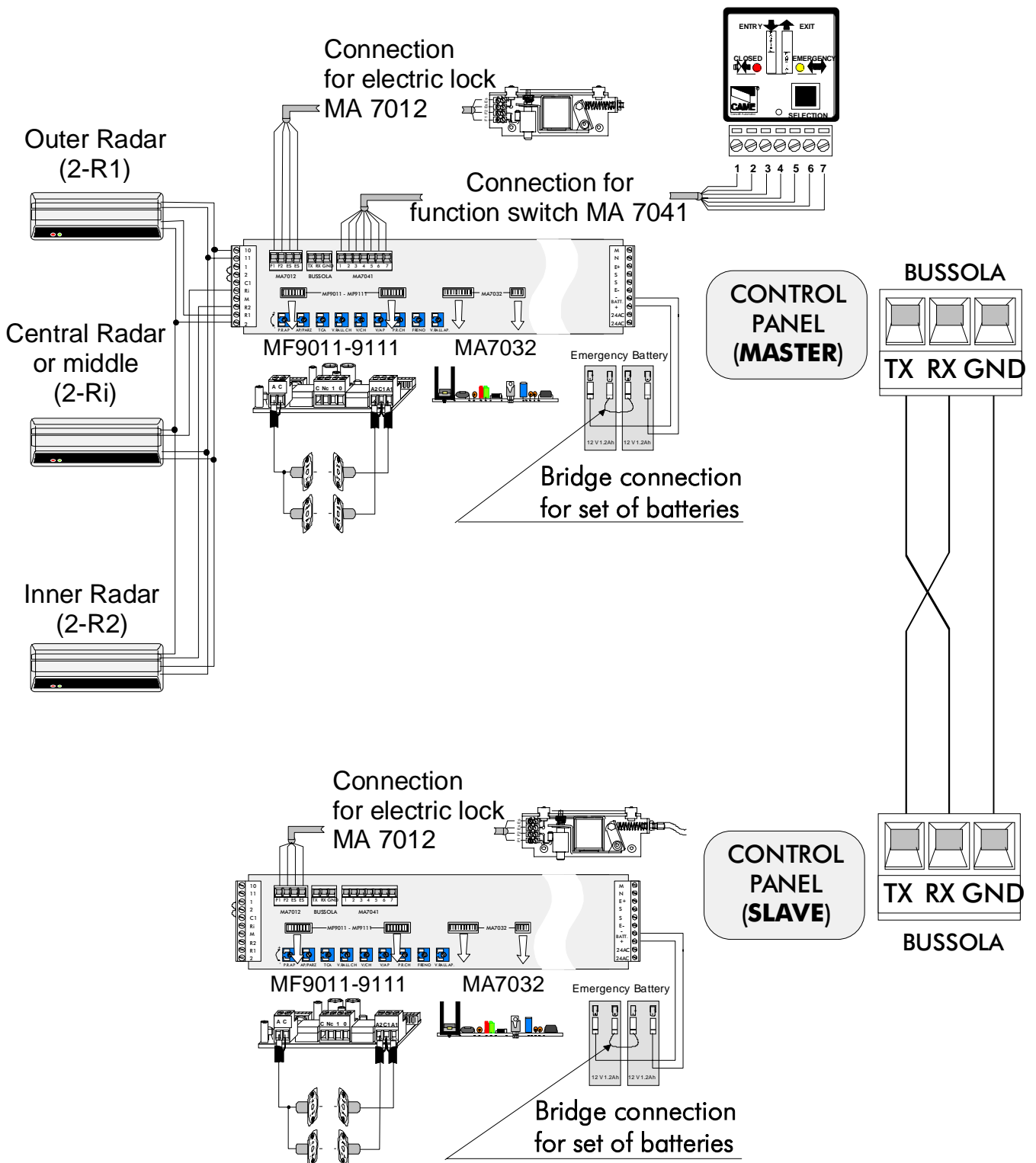

# CONNECTION OF ACCESSORIES TO THE PANEL

## FOREWORD

To facilitate the wiring procedure, the entire length of the beam is equipped with a space for lodging and distributing the cables.

Two no.2 (common) terminals have been provided on the terminal board for connection of accessories.

The power cables should be arranged on the left side of the beam, where the transformer is located.

The mains power and ground connection are connected to this transformer.

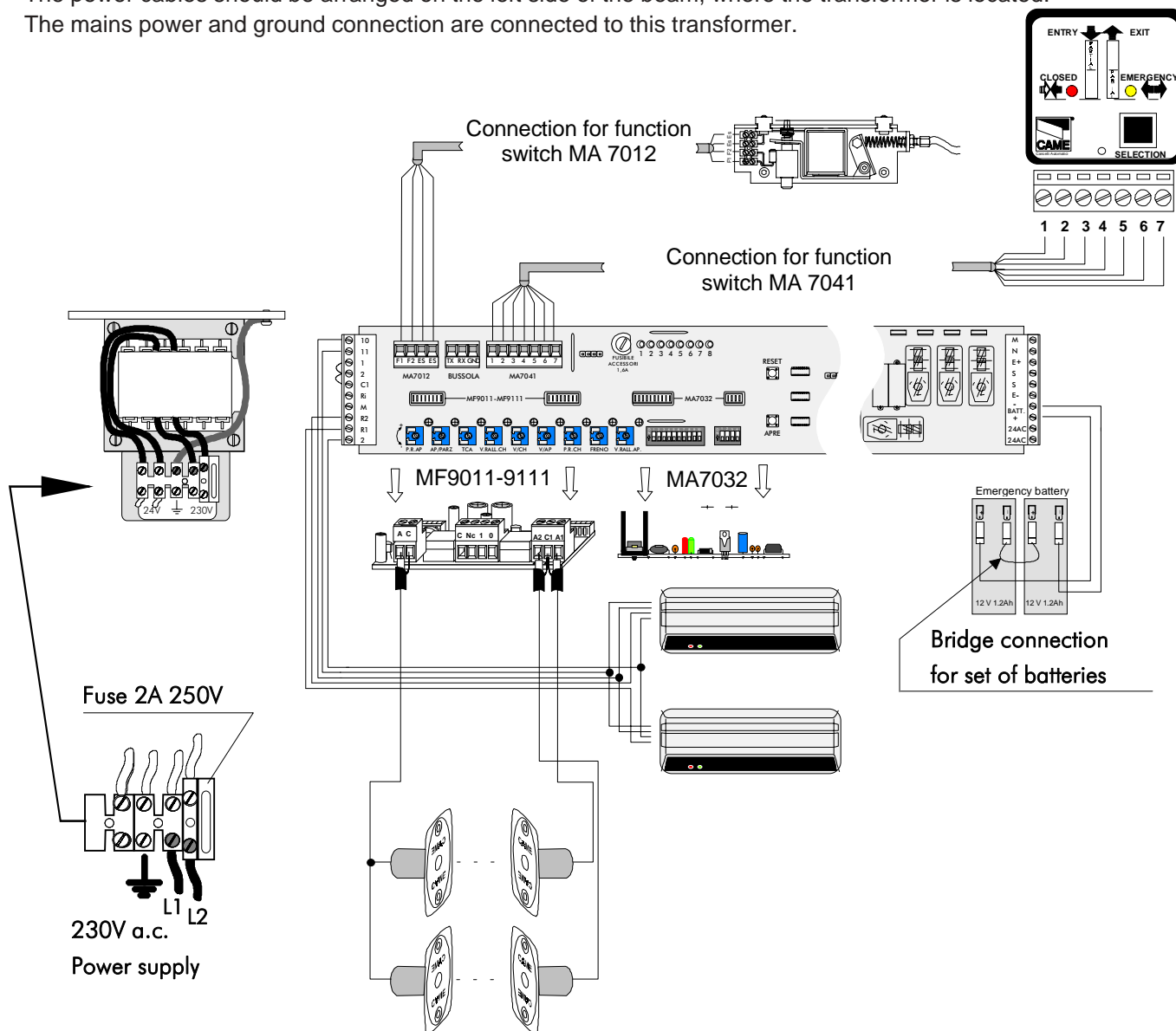

## SEQUENCE OF CONNECTIONS

- ✓ CONNECT OUTER SENSOR TO TERMINALS 2-R1 ON THE TERMINAL BOARD IN THE ELECTRICAL CABINET
- ✓ CONNECT INNER SENSOR TO TERMINALS 2-R2 ON THE TERMINAL BOARD IN THE ELECTRICAL CABINET
- ✓ CONNECT SENSOR POWER TO TERMINALS 10-11 ON THE TERMINAL BOARD IN THE ELECTRICAL CABINET
- ✓ CONNECT MAINS POWER<sup>(1)</sup> TO THE RELATIVE TERMINALS ON THE TRANSFORMER<sup>(2)</sup>
- ✓ CONNECT THE GROUND LEAD TO THE RELATIVE TERMINAL ON THE TRANSFORMER

<sup>(1)</sup> PROTECTED BY 30mA DIFFERENTIAL SAFETY SWITCH + 5A CIRCUIT BREAKER (AS FOR ITALIAN LAW 46/90)

<sup>(2)</sup> IF 24V A.C. POWER IS USED, THIS CONNECTION CAN BE MADE DIRECTLY ON THE TERMINAL BOARD IN THE ELECTRICAL CABINET.

### For 001MA7032

The leads for connecting the two batteries have been provided. Simply connect the batteries together using the bridge connection cable supplied with the system.

### For 001MF9011-9111

All that is needed is to insert the amplifier card into its appropriate place after connecting the sensors.

**N.B.:** If the card is not used, set dip switch 3 to ON (4-way dip switch).

No other connections are required. Bridge connection 2-C1 remains connected.

## ACCESSORIES

### SAFETY

- MF 9011** Pair of photocells with range of 7m.  
**MF 9111** Double pair of photocells with range of 7 m.  
**MA 7012** Electric lock, complete with release cord.  
**MA 7032** Emergency system, complete with batteries, for CORSA and RODEO systems.

### CONTROL

- MA 7041** Function switch  
**MR 8001** Narrow-field radar  
**MR 8002** Wide-field radar  
**MP 8030** Sensitive platform, 800 mm x 300 mm  
**MP 8060** Sensitive platform, 800 mm x 600 mm  
**MR 8104** Radar microware, 3 m max  
**MR 8105** Radar microware, 5 m max  
**MS 9502** Opening Sensor touch-type  
**MR 8334-70-90** Safety radar K4  
**MRT001** Remote control for MR8104 e MR8105

### FOR DOOR WINGS WITH FRAME

Complete kit for connecting with EXTERNAL floor guide RUNNERS to 10-mm GLASS doors (to be used with MA7370/7470/7570)

- MA 7353** L 1000 mm  
**MA 7453** L 1500 mm  
**MA 7553** L 2000 mm

Complete kit for connecting with INTERNAL floor guide RUNNERS to Framed doors (to be used with MA7371/7471/7571)

- MA 7351** L 1000 mm  
**MA 7451** L 1500 mm  
**MA 7551** L 2000 mm

### FOR GLASS DOOR WINGS (with max thickness of 10 mm.)

Kit complet pour fixer les VANTAUX En VERRE de 10mm, avec patinS DE guidaGE INTERNES au sol (a utiliser avec MA7370/7470/7570)

- MA 7353** L 1000 mm  
**MA 7453** L 1500 mm  
**MA 7553** L 2000 mm

Complete kit for connecting with EXTERNAL floor guide RUNNERS to 10-mm GLASS doors

- MA 7370** L 1000 mm  
**MA 7470** L 1500 mm  
**MA 7570** L 2000 mm

**MAM 600** Central weather stripping for sliding glass doors (package of 30 m.)

**MAM 601** Lateral weather stripping for non-moving and sliding glass doors (package of 30 m.)

### BREAKTHROUGH ANTI-PANIC SYSTEM for:

- MI 6010** 1 mobile door (L=1,100 mm per door)  
**MI 6110** 1 mobile door (L=1,500 mm per door)  
**MI 6020** 2 mobile doors (L=1,100 mm per door)  
**MI 6120** 2 mobile doors (L=1,500 mm per door)  
**MI 6030** 1 mobile door and 1 fixed door (L=1,100 mm per door)  
**MI 6130** 1 mobile door and 1 fixed door (L=1,500 mm per door)  
**MI 6040** 2 mobile doors and 2 fixed doors (L=1,100 mm per door)  
**MI 6140** 2 mobile doors and 2 fixed doors (L=1,500 mm per door)

**OUR S20 AND S40 SYSTEMS ARE ALSO AVAILABLE FOR THE COMPLETE CONSTRUCTION OF SLIDING ALUMINIUM DOORS. THESE SYSTEMS ARE SPECIALLY DESIGNED FOR USE WITH RODEO AUTOMATION SYSTEMS.**

MALFUNCTIONS	RIFERIMENTI	POSSIBLE CAUSES
- The automation system does not open	A - B - C - D - E - F - J - K - N - S - T - U - V - X - Z	<b>A</b> No power or incorrect power is being supplied from the power mains.
- The automation system does not close	D - E - F - G - H - K - L - J - N - R - S - V - Z	<b>B</b> The fuses are blown. <b>C</b> Initial programming - lacking or unsuitable <b>D</b> Function switch is set to the wrong position. <b>E</b> Electrical connections are wrong.
- The automation system does not open completely	C - D - K - O - P - Q - S - V - W - X - Y - Z	<b>F</b> Bridge connection 1-2 is missing <b>G</b> Safety devices are not connected to contacts 2 -C1 and the contacts have not been short-circuited.
- The automation system does not close completely	C - H - K - O - P - Q - S - V - W - X - Z	<b>H</b> Safety photocells are improperly aligned or inoperative. <b>I</b> Dip 3 (4-way module) to select
- The automation system operates at reduced speed, only	S - Q - W - V - X - Y	<b>J</b> Motor connections are wrong. <b>K</b> Encoder is inoperative.
- The automation does not maintain the initial settings	O - P - Q - S - V - W - X - Y - Z	<b>L</b> Circuit card MA7032 for the emergency system is inoperative. <b>M</b> Batteries are dead.
- The electric lock does not unlock to allow the door to open	E - S - T - U	<b>N</b> Dip 2 (10-way module) activated (function verification on page 18) <b>O</b> Slow-down adjustments (open and close) inadequate <b>P</b> Adjustments of the slow-down points (open and close)
- The photocells do not operate	E - G - H - I - S	<b>Q</b> Speed adjustments (open and close) inadequate <b>R</b> TCA adjustment, excessive
- The automation system does not operate in the manner selected on the function switch	E - J - S	<b>S</b> ZP7 main board is inoperative. <b>T</b> Microswitch on electric lock is inoperative.
- The emergency system does not operate	D - L - M - N - V - W - X - Y	<b>U</b> The bracket that engages the electric lock to the trolley is incorrectly positioned. <b>V</b> Mechanical interference is occurring between moving door wings and non-moving parts (for example: door wings/pavement; non-moving door wings/moving door wings; moving door wings/pavement-mounted guides; weather stripping/non-moving door wings)
- The automation system is excessively noisy	V - W - X - Y	<b>W</b> There is mechanical interference with the drive system (for example: interference between trolleys and cables). <b>X</b> Scraps of materials / objects are present in guide track. <b>Y</b> Belt tension is incorrect. <b>Z</b> Mechanical stops are incorrectly positioned.
ALSO, SEE THE SECTION ON THE "FUNCTIONS OF INDICATOR LEDS"		

## NOTES

## SERVICE CENTRE

## DATE

Tutti i dati sono stati controllati con la massima cura. Non ci assumiamo comunque alcuna responsabilità per eventuali errori od omissioni.

All data checked with the maximum care. However, no liability is accepted for any error or omission.

Toutes les données ont été contrôlées très soigneusement. Nous n'assumons de toute façon aucune responsabilité pour les erreurs ou omissions éventuelles.

Die Daten wurden mit höchster Sorgfalt geprüft. Für eventuelle Fehler oder Auslassungen übernehmen wir keine Haftung.

Todos los datos se han controlado con la máxima atención. No obstante no nos responsabilizamos de los posibles errores u omisiones.



ASSISTENZA TECNICA  
NUMERO VERDE  
800 295830  
WEB  
www.came.it  
E-MAIL  
info@came.it



CAME LOMBARDIA S.R.L. COLOGNO M. (MI)

☎ (+39) 02 26708293 ☎ (+39) 02 25490288

CAME SUD S.R.L. NAPOLI

☎ (+39) 081 7524455 ☎ (+39) 081 7529109

CAME (AMERICA) L.L.C. MIAMI (FL)

☎ (+1) 305 5930227 ☎ (+1) 305 5939823

CAME AUTOMATISMOS S.A. MADRID

☎ (+34) 091 5285009 ☎ (+34) 091 4685442

CAME BELGIUM LESSINES

☎ (+32) 068 333014 ☎ (+32) 068 338019

CAME FRANCE S.A. NANTERRE CEDEX (PARIS)

☎ (+33) 01 46130505 ☎ (+33) 01 46130500

CAME GMBH KORNTAL BEI (STUTTART)

☎ (+49) 07 11839590 ☎ (+49) 07 118395925

CAME GMBH SEEFELD BEI (BERLIN)

☎ (+49) 03 33988390 ☎ (+49) 03 339885508

CAME PL SP.ZO.O WARSZAWA

☎ (+48) 022 8365076 ☎ (+48) 022 8369920

CAME UNITED KINGDOM LTD NOTTINGHAM

☎ (+44) 01159 387200 ☎ (+44) 01159 382694

CAME CANCELLI AUTOMATICI S.P.A.

DOSSON DI CASIER (TREVISO)

☎ (+39) 0422 490960 ☎ (+39) 0422 490944