

MI6030 - 6130 MI6040 - 6140

COMPLETE MECHANICAL ENSEMBLE
to be applied on sliding opening frames.
In emergencies, it allows the **OPENING** of the **ESCAPE EXIT**
by **BREAKING THROUGH THE DOORS**.

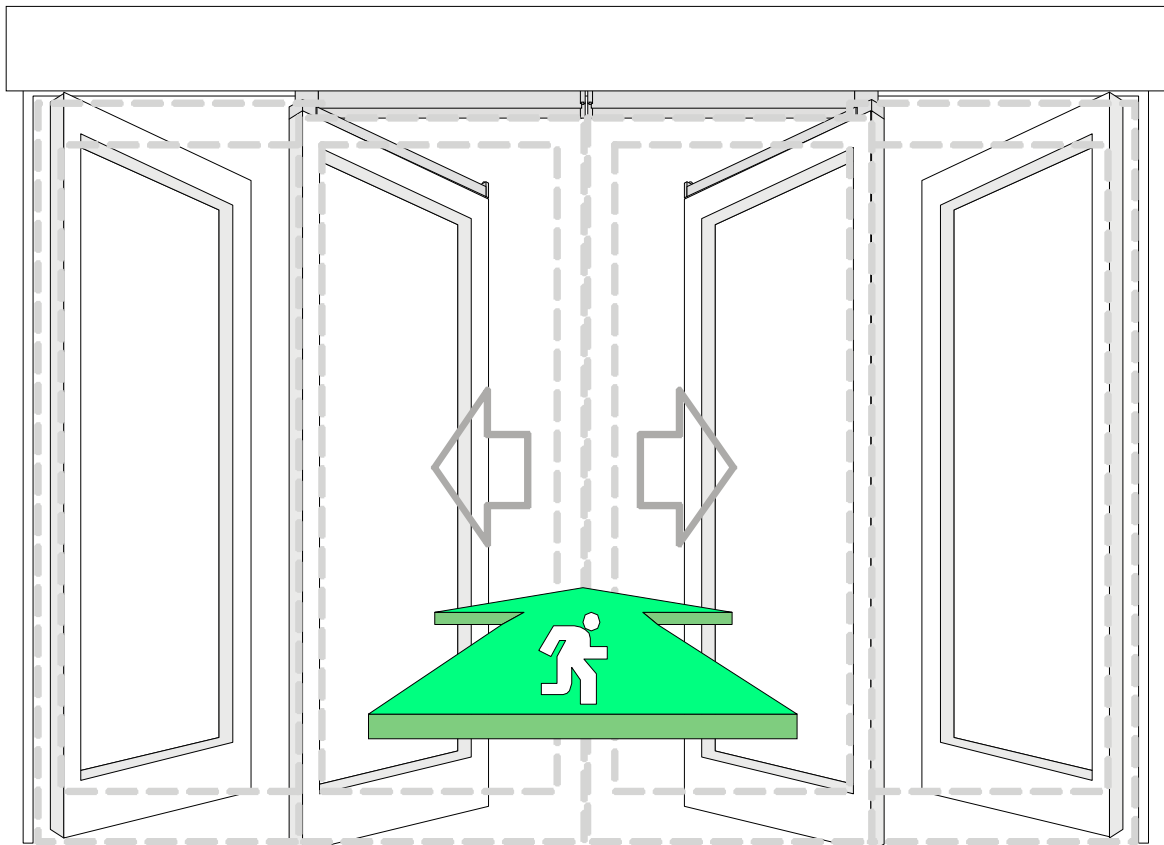

Up to **120** kg per door

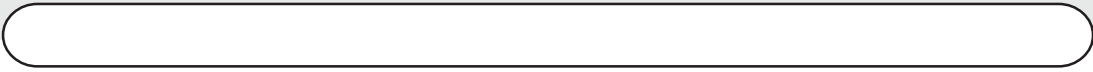

This page left intentionally blank

TABLE OF CONTENTS

- pg. 4 - Operation and Use Limits
- pg. 5 - Type of MI Antipanic System
- pg. 6/7 - What the MI Package Contains

MI FOR COMMERCIAL SERIES

- pg. 10÷18 - Section types and special instructions for door construction

MI FOR CAME S40 SERIES

- pg. 20/21 - Section Types
- pg. 22 - MI Antipanic Bar Machining
- pg. 23÷25 - Mounting of MI Antipanic System
- pg. 26 - Spiral cable application and mobile door mounting
- pg. 27 - Power connections

OPERATION and USE LIMITS

Complete antipanic breakthrough can be achieved **NO MATTER WHAT POSITION THE SLIDING DOORS ARE IN** during movement; this is also true of the **FIXED DOORS**.

To ensure a steady flow or for the passage of bulky objects, the fixed and mobile doors can be broken through and gathered at both sides of the doorframe.

The sliding door/doors is/are reactivated by simply moving the door/doors to the side.

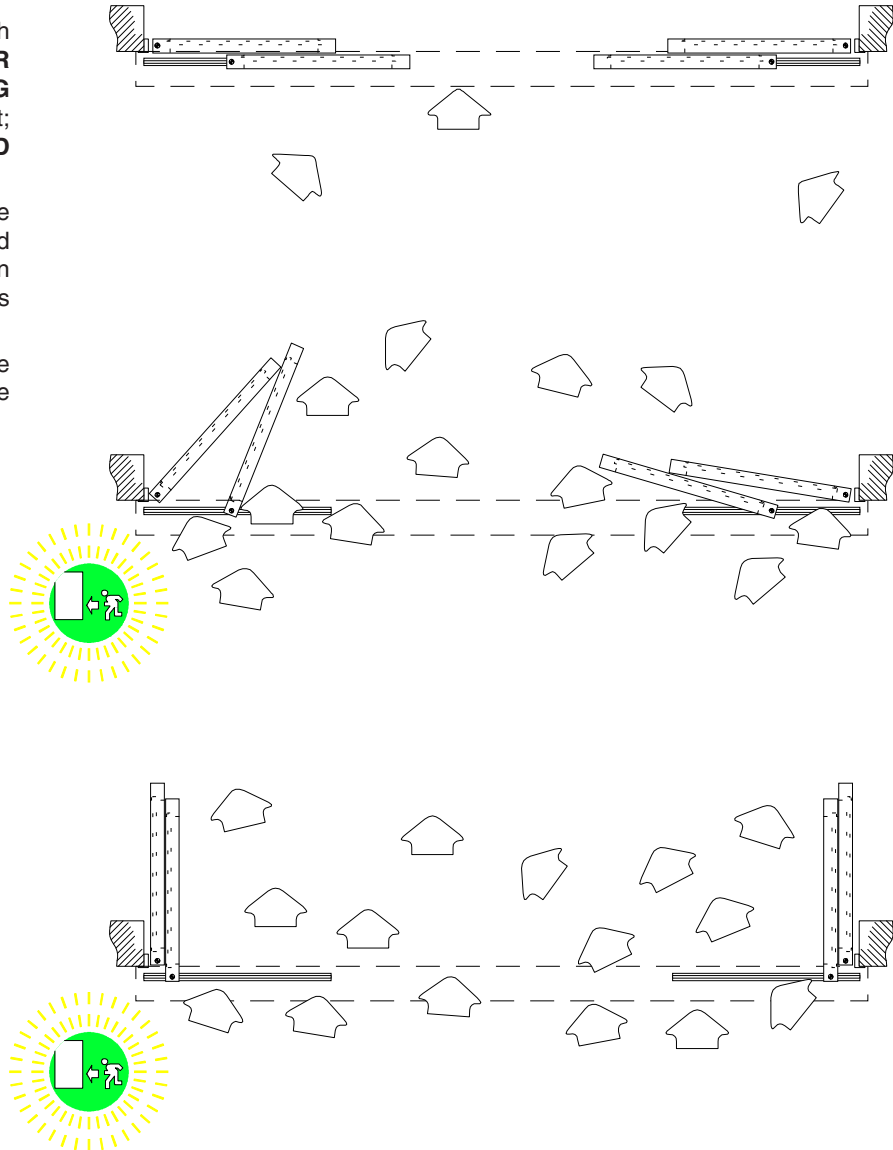

EMPLOYMENT LIMITS

For **MI6030** and **MI6040** (door width of up to 1100 mm), the maximum weight for each door indicated can be increased by attaching a **sliding wheel** on the ground (part. P4173, pages 6 & 18).

WARNING: if the P4173 sliding wheel is added, the adequate linearity of the plane on which it must turn must be ensured.

Width A (mm) SINGLE DOOR	Max. weight (kg) admitted per SINGLE DOOR	
	With CORSA automatic system	With RODEO automatic system
500	75	120
600	75	90
700	75	80
800	60	70
900	50	60
1000	45	50
1100	40	40
The mounting of the P4173 wheel is mandatory with over 1100 and up to 1500 mm (MI6130/MI6140) .		

Types of MI Antipanic Systems

COMPLETE ANTIPANIC BREAKTHROUGH
SYSTEM FOR **1 SLIDING** AND **1 FIXED**
DOORS SYSTEMS

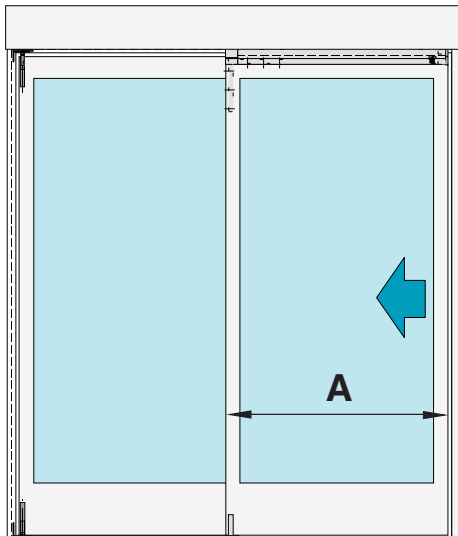

with **A** up to 1100 mm = **MI6030**
with **A** up to 1500 mm = **MI6130**

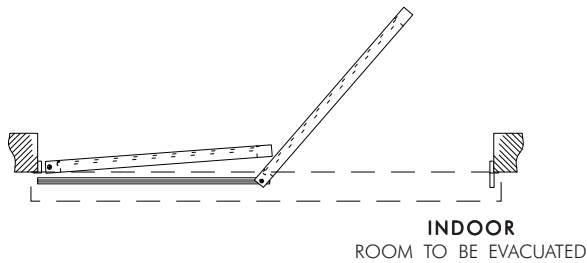

COMPLETE ANTIPANIC BREAKTHROUGH
SYSTEM FOR **2 SLIDING** AND
2 FIXED DOORS SYSTEMS

with **A** up to 1100 mm = **MI6040**
with **A** up to 1500 mm = **MI6140**

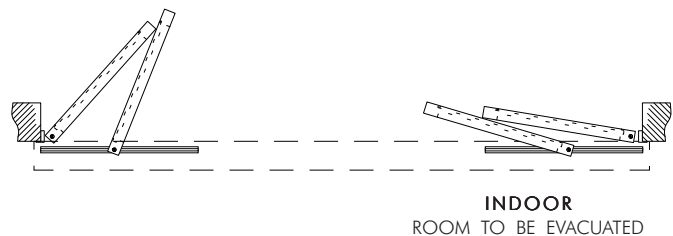
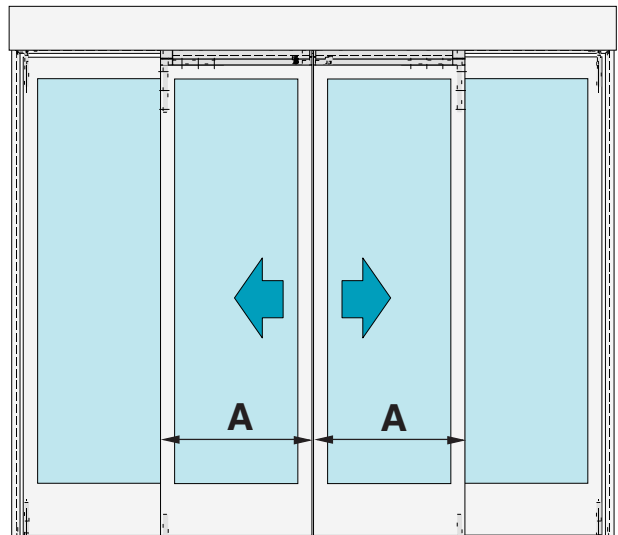

Antipanic breakthrough kit components

ANTIPANIC SYSTEM FOR MOBILE DOOR

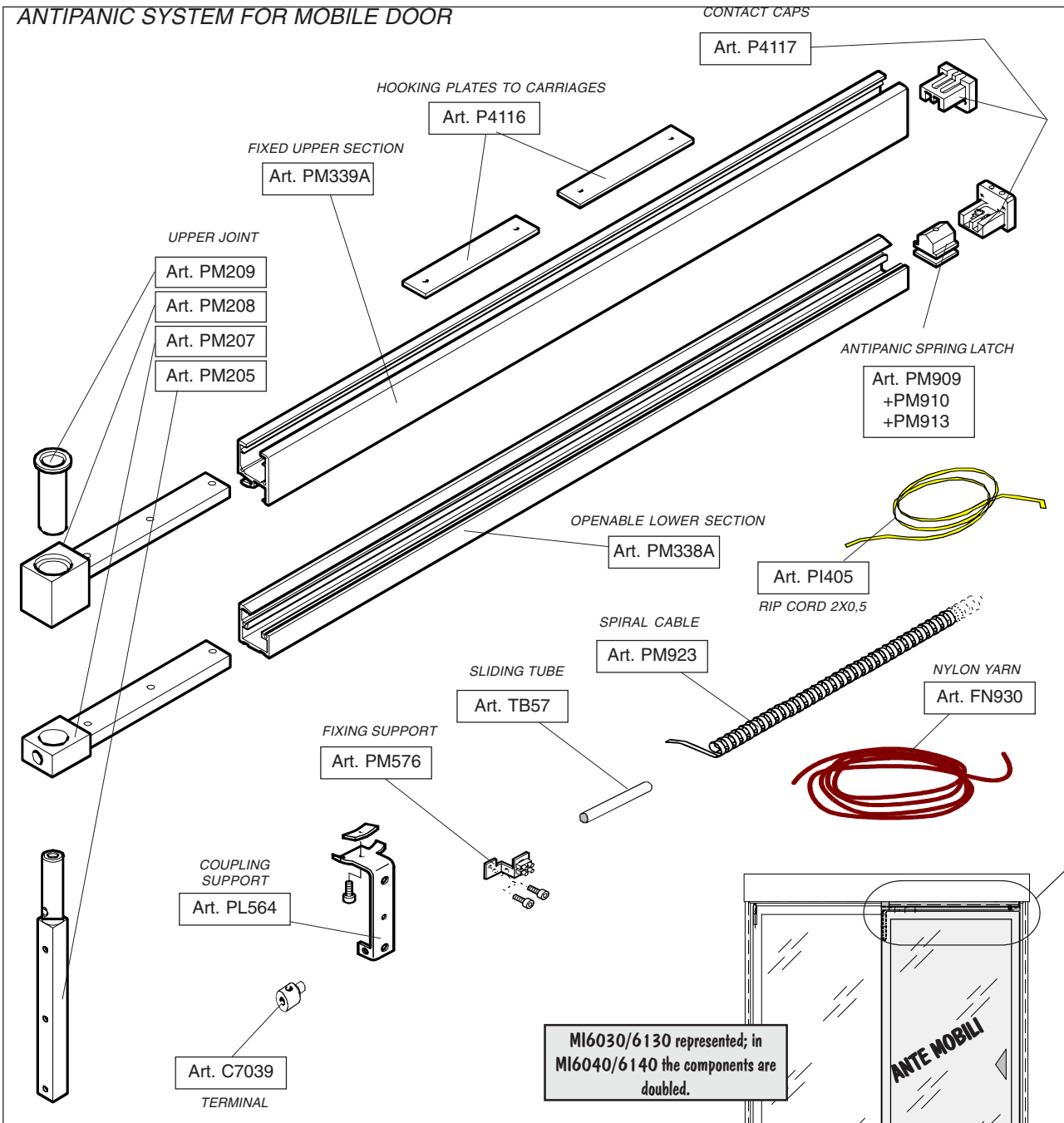

LOWER HINGE FOR MOBILE DOOR

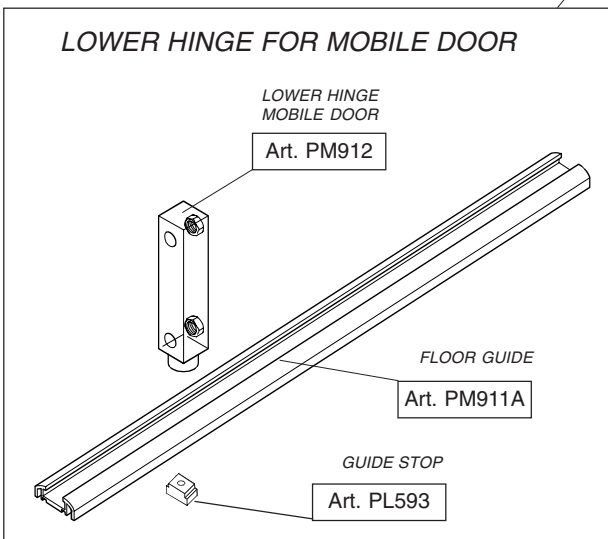

SLIDING WHEEL

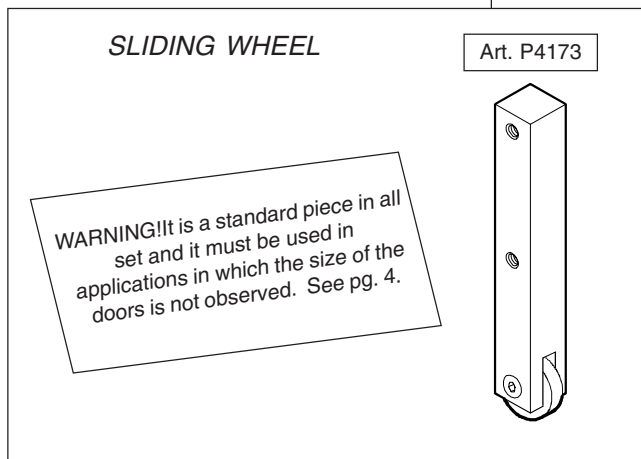

Antipanic breakthrough kit components

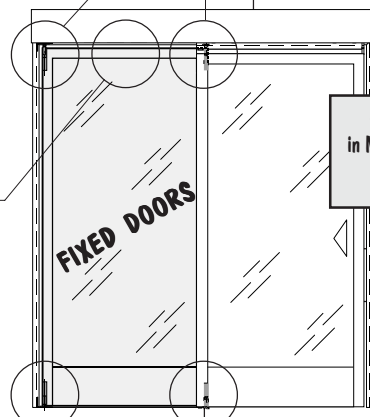
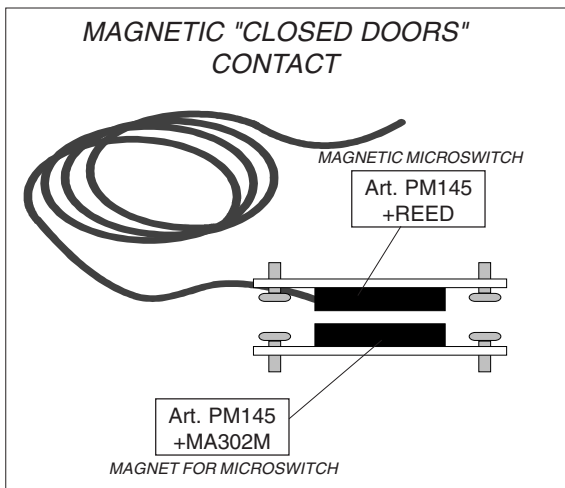
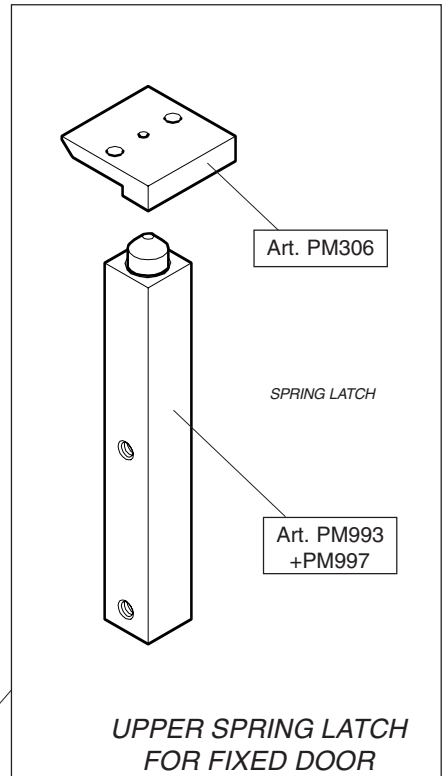
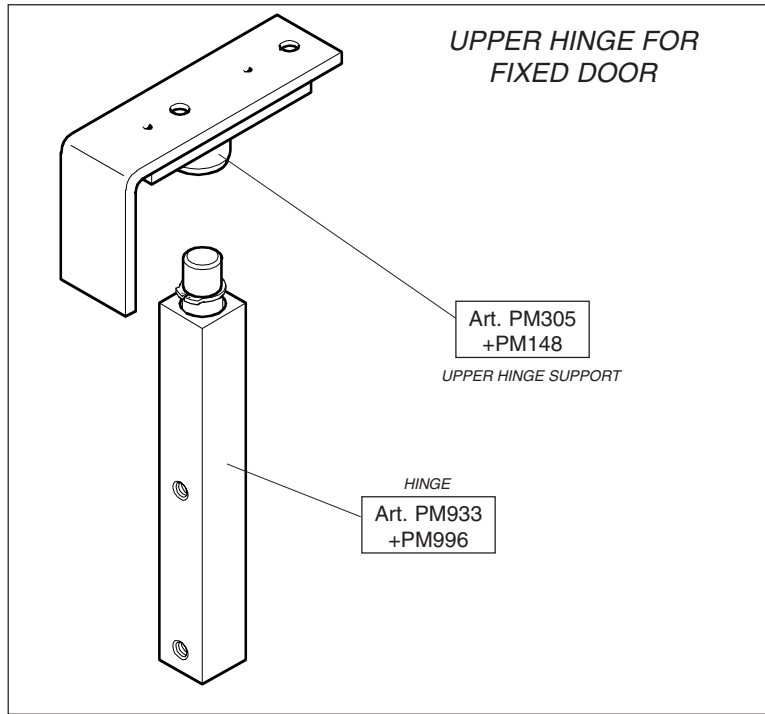

MI6030/6130 represented;
in MI6040/6140 the components
are doubled.

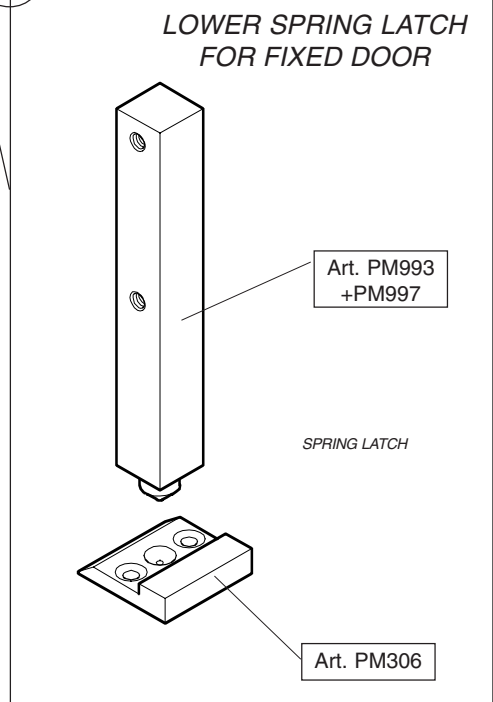
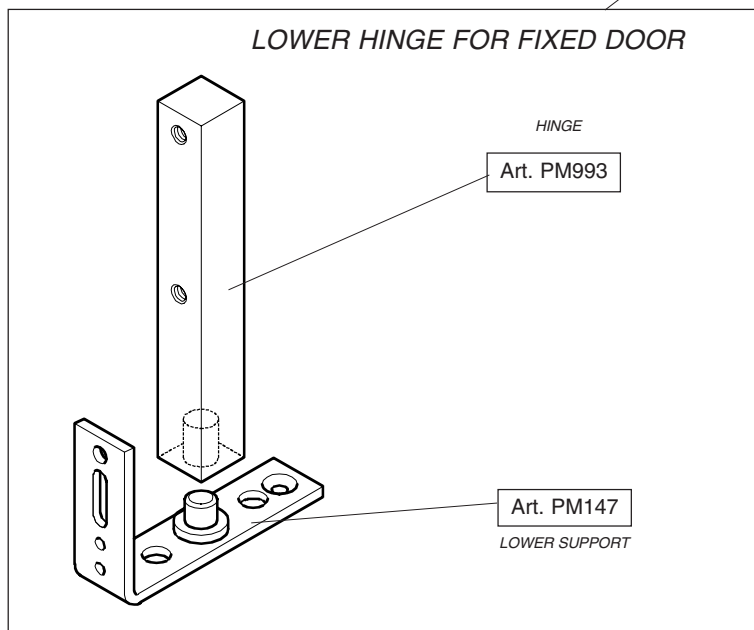



This page left intentionally blank

MI System

applied to
commercial series
of sections for
automatic sliding doors

The sections, sizes, weather strip and everything else mentioned in the following pages as ***commercial series*** are purely indicative and appear solely for the purpose of illustrating the applicability of the MI system on sliding doors with frames other than our series **S40** type.

Our MI antipanic breakthrough series have been designed to be applied even on sliding doors built with any type of adequately adapted commercial series. To this purpose, the following pages contain the necessary measurements and/or notes to plan and resize the doors.

Preliminary Notes:

WALL-TYPE FRAMES:

- They must be able to contain the hinging corners (pg. 14/15);
- Machining and thickening must be performed according to the best functional lodging of the hinges;
- It is important to set adequate passages for the "CLOSED DOORS" sensor connections and photoelectric cells.

FIXED AND MOBILE DOORS

- The preparation of the doorframes must allow the insertion of the hinge pins; it is recommended that the faced and fixed cross members be mounted with U-bolts;
- Pay attention to how the hinge elements are attached to the structure. They should be fixed rigidly in order to avoid that with time vibrations and movement limit efficiency and make the system unsafe for users;
- If the structure is not strong enough, the assembler must reinforce it.
- Upper and lower hinges must be aligned axially.
- Only in case of mobile doors, it is recommended that the glass be firmly set with silicone sealant in addition to any other types of weather strip.
- Only stratified or tempered glass should be used.

MACHINING SEQUENCE

FRAME

- Follow directions on page 14 for wall-type frame machining and assembly. Pay particular attention to hinge axle alignment.
- It is possible to make both vertical and horizontal adjustments for the alignment of the fixed door by turning the adjustment screws.
- Ensure adequate passages for the "closed doors" magnetic sensor cables and for the photoelectric cells.

FIXED DOORS

- Resize the doors according to the dimensions and the useful characteristics referring to the notes on sizes in pages 12/13.
- Carry out work for the housing of hinging devices as indicated in pages 15/16; prepare housings for any photoelectric cells.
- Assemble the devices indicated, making sure the hinges and spring latches are aligned axially.
- Insert the fixed doors in the hinge supports, working with a screwdriver for the insertion of the upper pin (pg. 15); align the doors and set the adjustments of the hinges.
- Align the closing blocks (PM306) to the closing spring latches in the "closed doors" position and fasten the blocks to the upper frame and to the ground (pg. 16).

MAKE SURE THE BREAKTHROUGH SIDE IS CORRECT!

- Align and lock the "closed doors" magnetic contacts.

MOBILE DOORS:

- Resize the length of the upright and cross sections according to the size of the sections used- follow indications on pages 12/13.
- Fasten the elements that make up the antipanic system for mobile doors.
- If necessary, insert the "wheel" device (art. P4173). See pg. 18.

ANTIPANIC BAR

- Cut sections PM339A and PM338A and chamfer and bore holes in section PM338A as indicated on page 22.
- Apply the bar on the mobile door, mount the spiral cable and finish mounting the doors on the Corsa or Rodeo beam, adapting the instructions for the S40 series on pages 24-26.
- Carry out the power connections and checks as indicated on page 27.

MAKE SURE THE BREAKTHROUGH SIDE IS THE CORRECT ONE AND THAT THE ANTIPANIC SYSTEM FOR MOBILE DOORS IS COMPLETE BEFORE PERFORMING ANY MACHINING WORK!

Horizontal sections with the COMMERCIAL SERIES

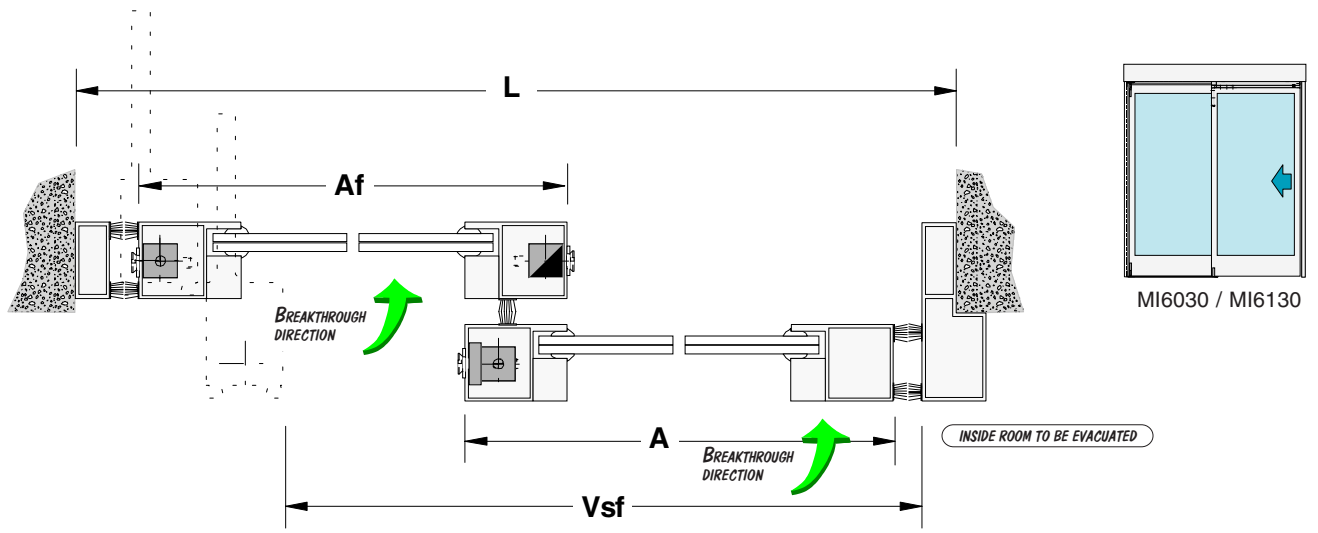

LEGEND

- L** = Wall opening width
- A*** = Sliding door width
- Af** = Fixed door width
- Vsf** = Width of passage created with breakthrough

Other specific sizes are not provided for the doors.
Please refer to the door supplier's documentation.

* Use **MI6030** or **MI6040** with **A** up to **1100**;
use **MI6130** or **MI6140** with **A** up to **1500**.

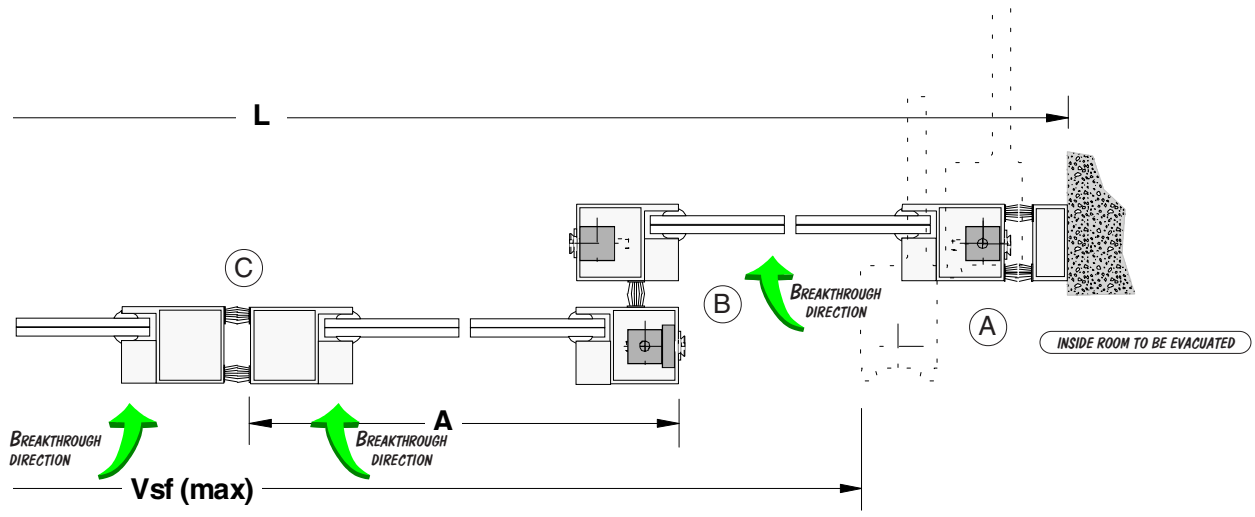
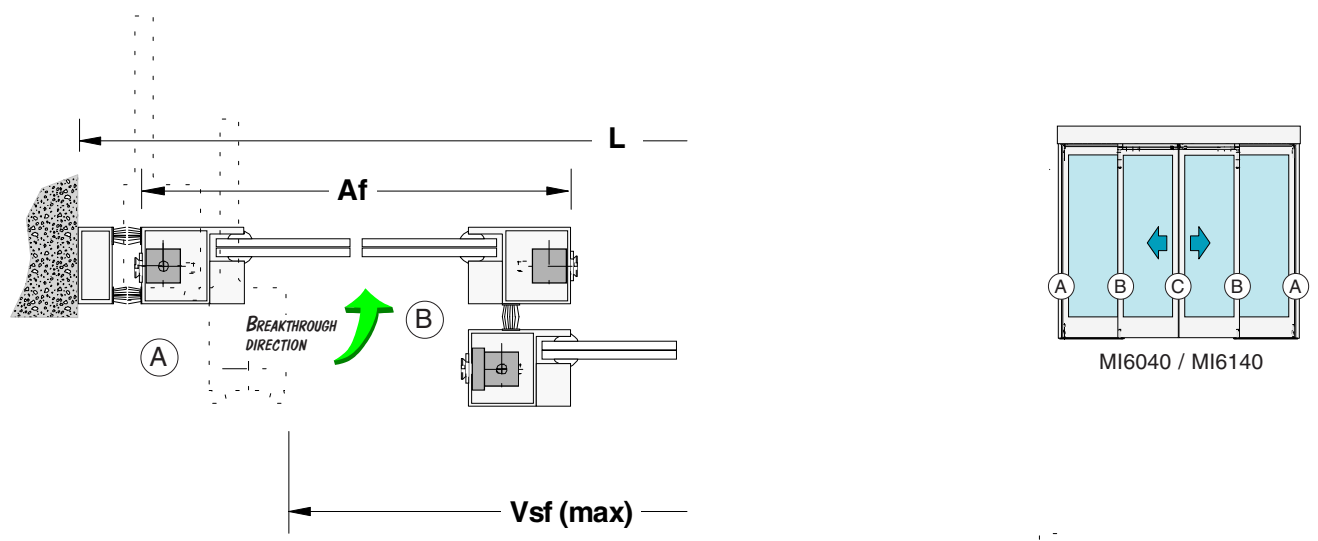

FIXED FRAMES

machining work on the fixed frame depend on the section series used in the construction of the door system; it is therefore important to take into account the size and dimensions indicated in the sections illustrated in the previous pages

A) upper hinge:

- it is recommended that an access area be allowed for the hinge for easier mounting, adjustment and/or maintenance (as in the figure).

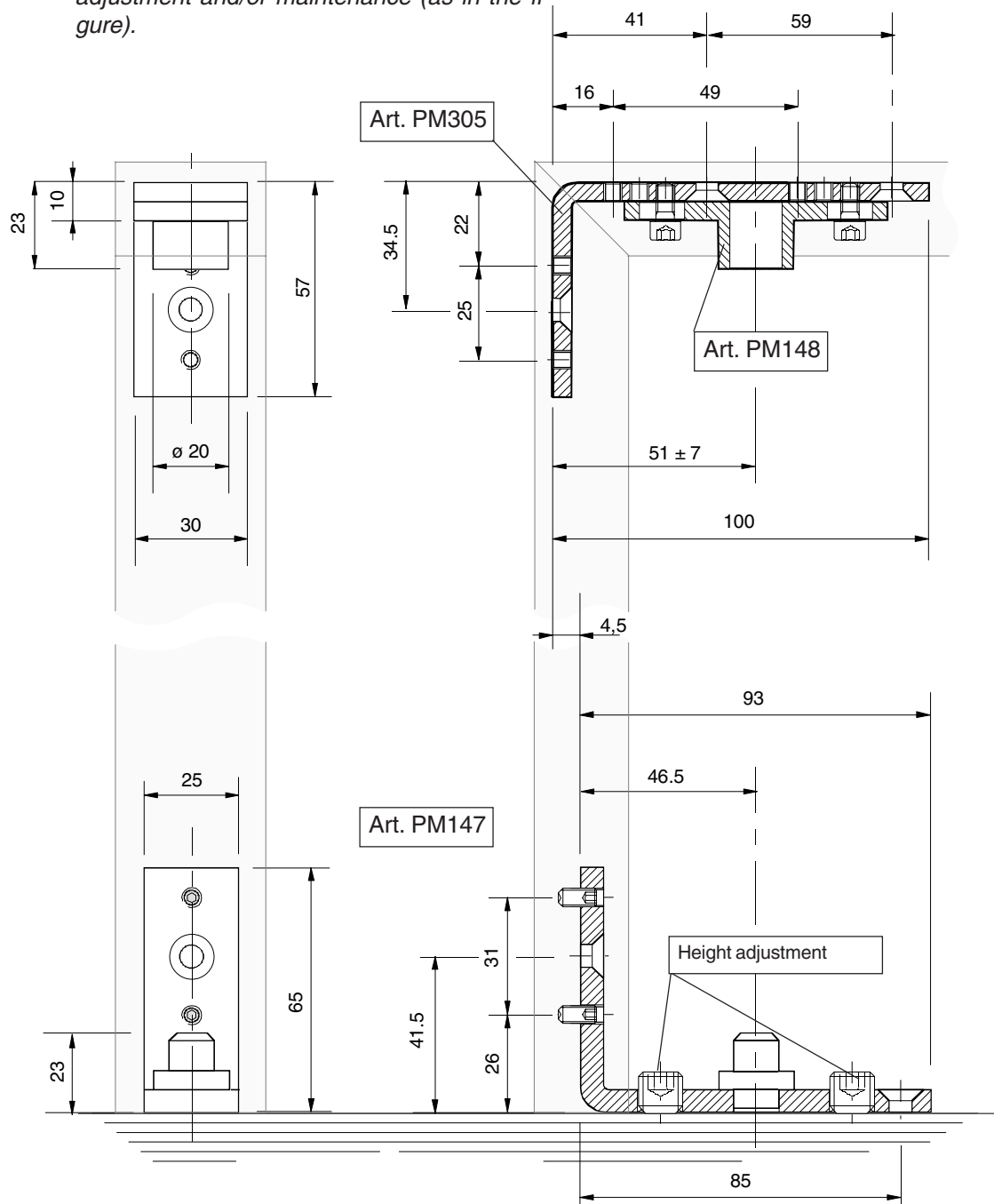

B) lower hinge:

- alignment to the upper hinge should be carried out at the adjustment median so as to allow subsequent adjustments during installation.

HINGING OF FIXED DOORS

To mount the fixed door, press the Seeger ring with a screwdriver to lower the pin and make it enter the hinge seat.

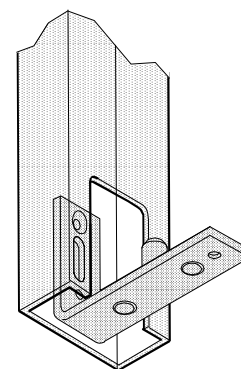
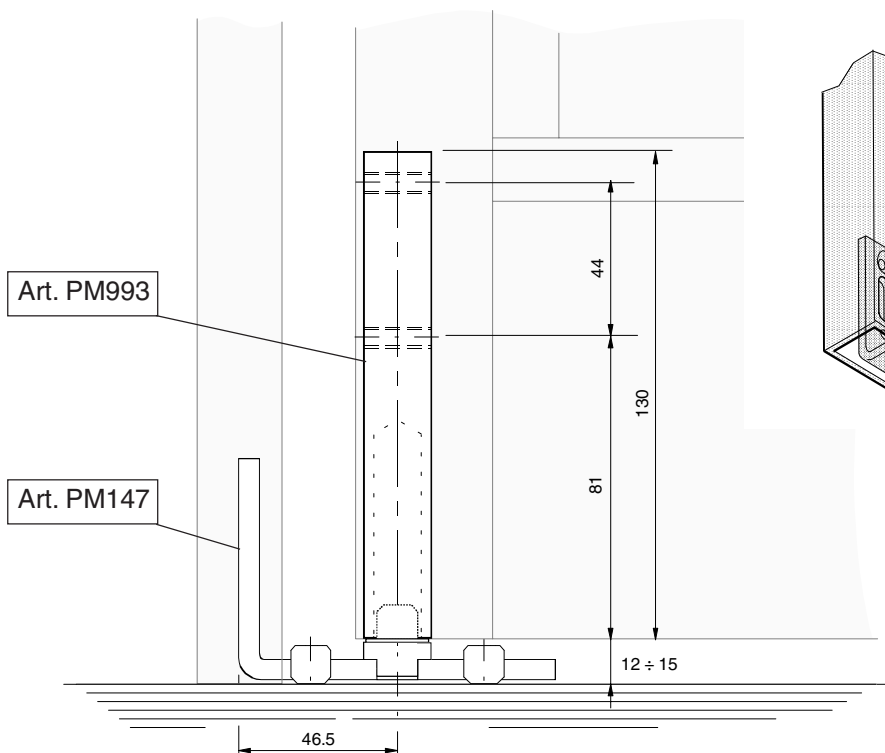
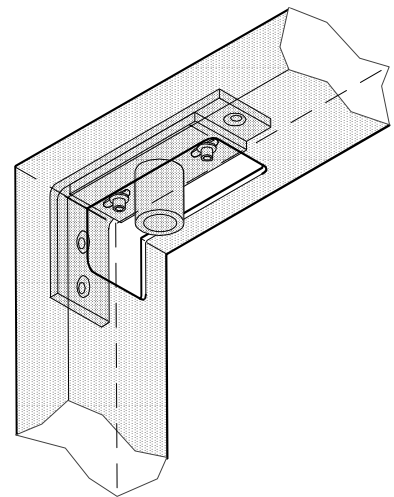
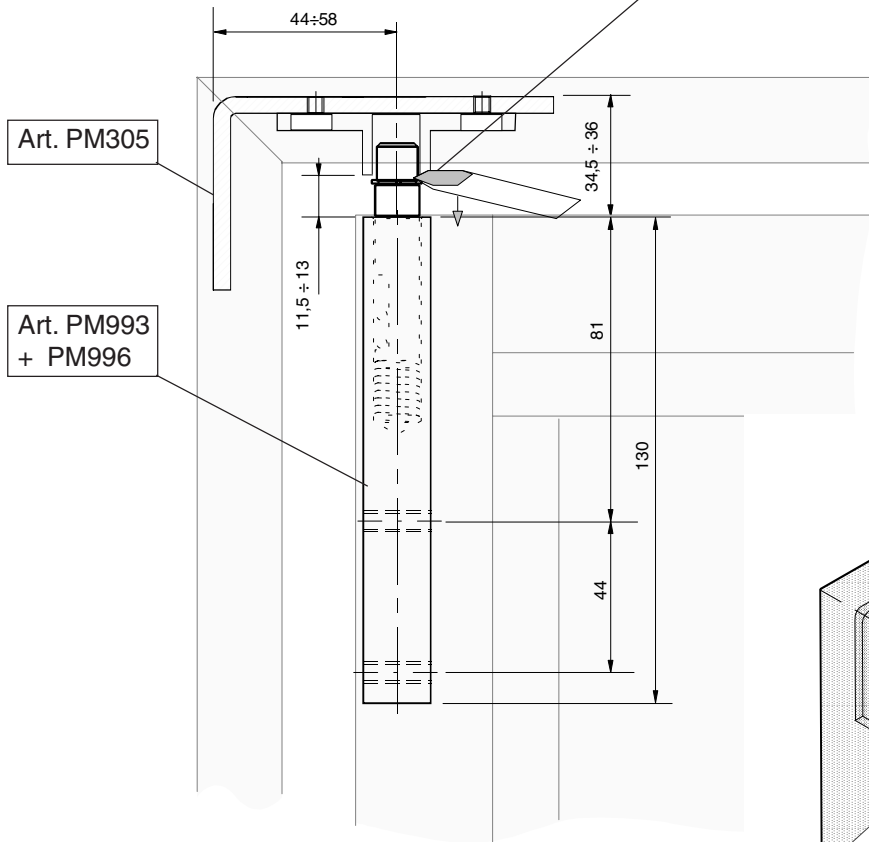

COMMERCIAL SERIES mounting instructions

**FIXED DOORS
SPRING LATCH**

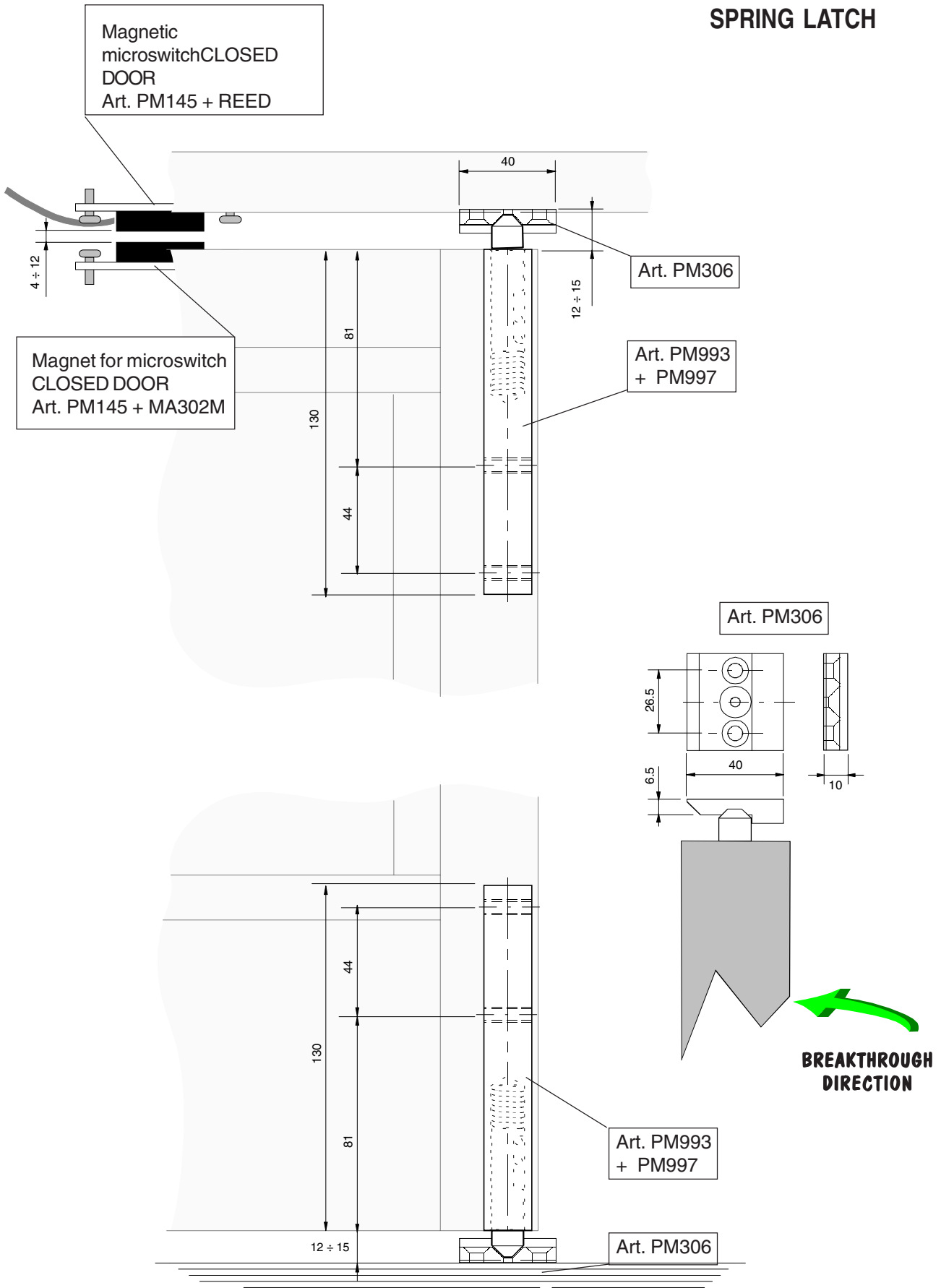

MOBILE DOOR
HINGING

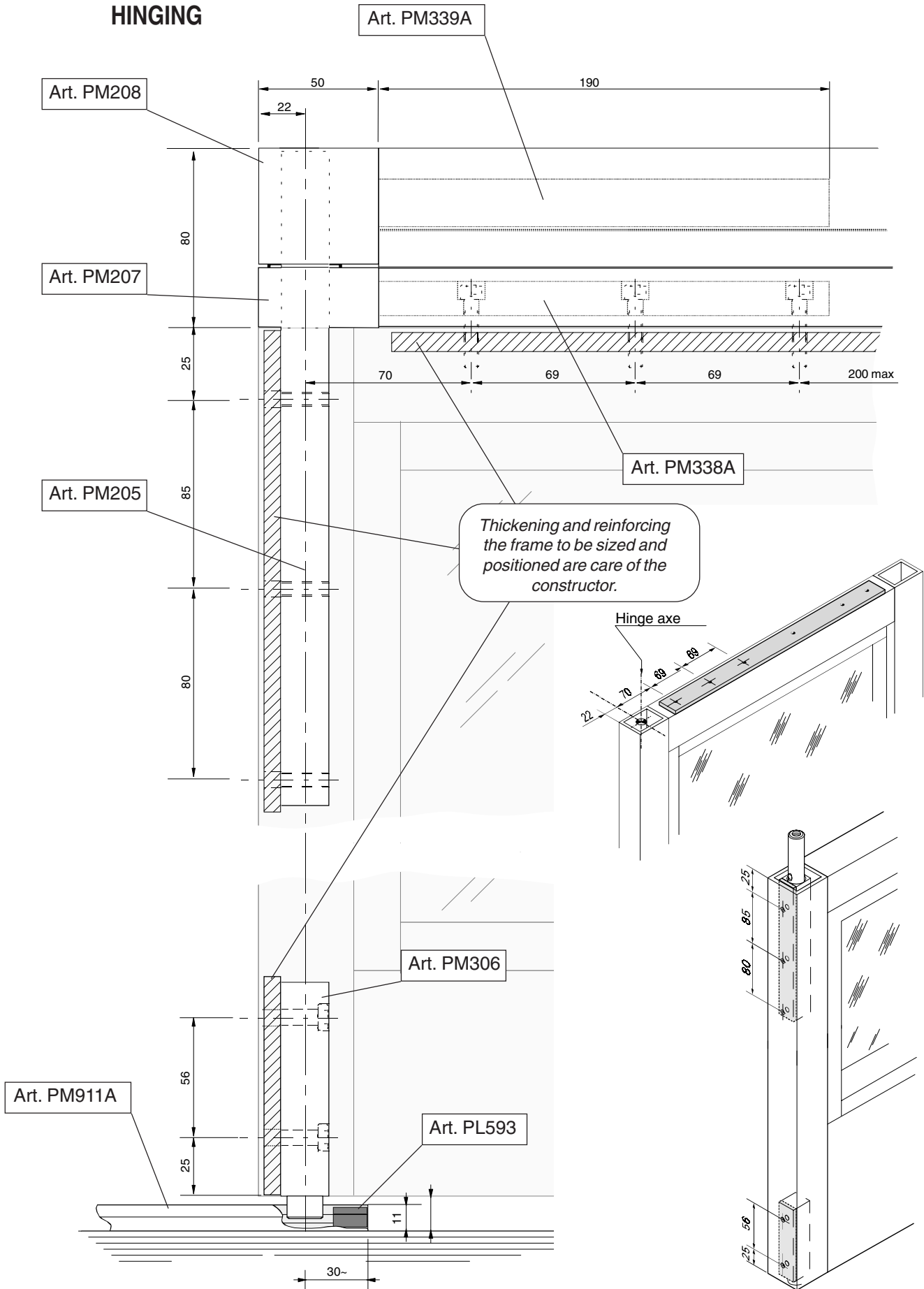

COMMERCIAL SERIES mounting instructions

**MOBILE DOORS
FRONTAL MATCH**

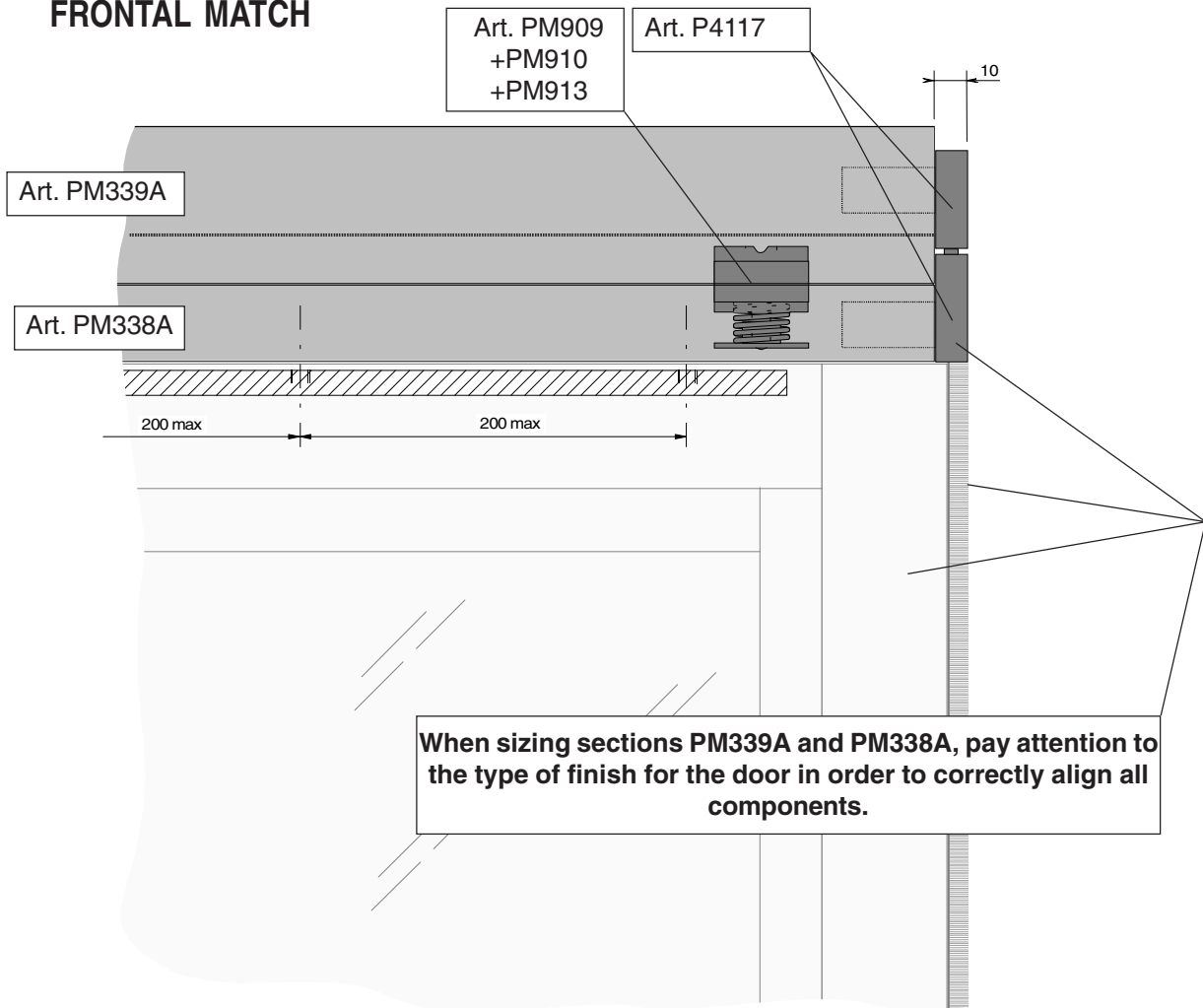

SLIDING WHEEL - OPTIONAL

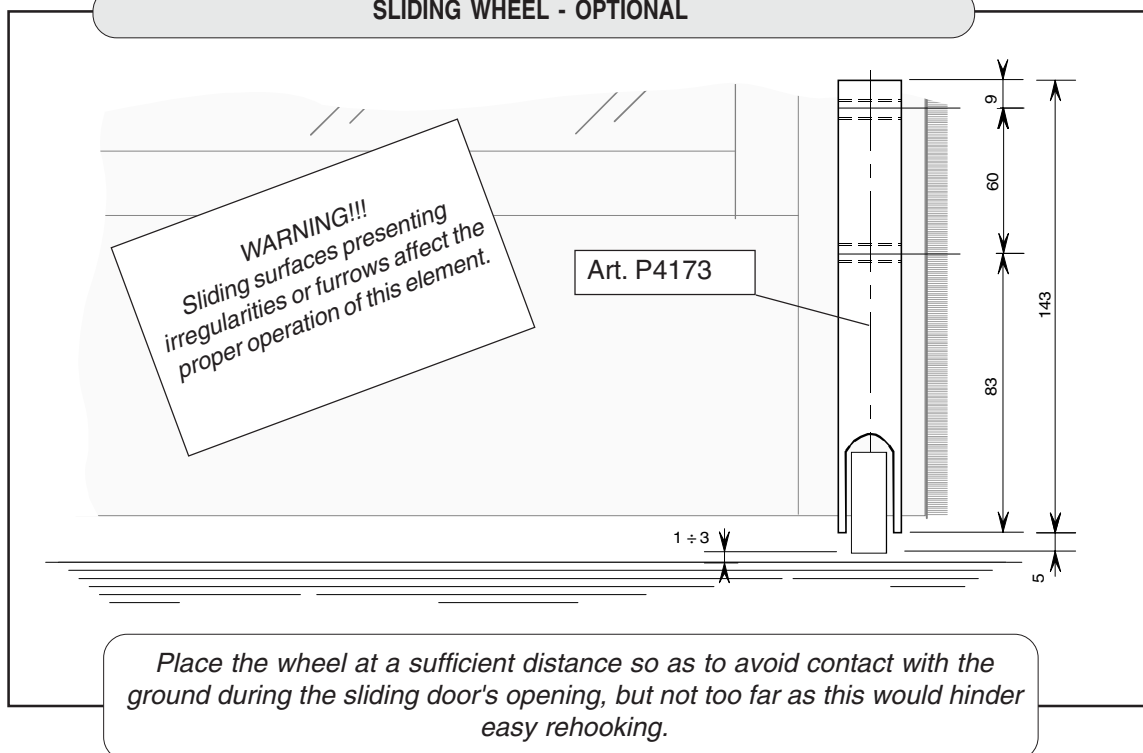

MI System

Applied to our section series

for **S40**

automatic sliding doors

The following two pages have only some application examples with our sections; for a complete series of the construction types, heights and construction parts for the creation of these doorframes, please refer to the **technical documentation** of the **S40** series.

S40 series - sections

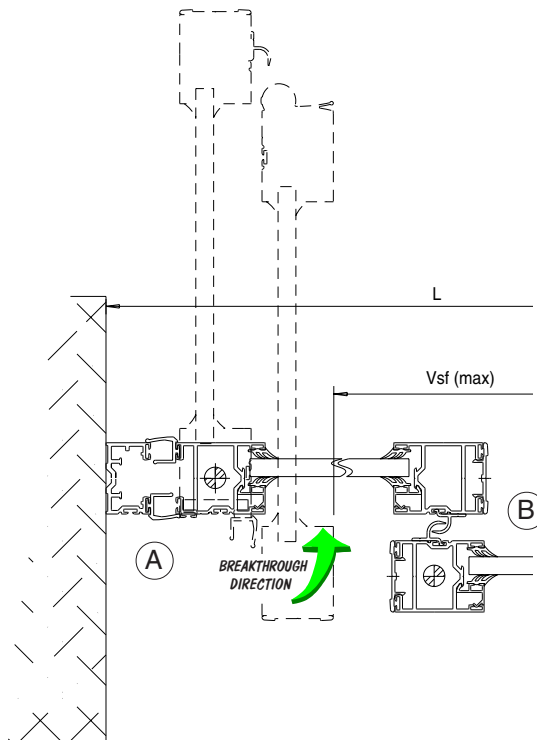
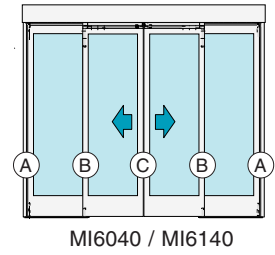
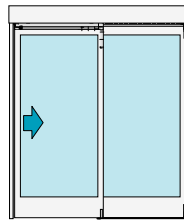
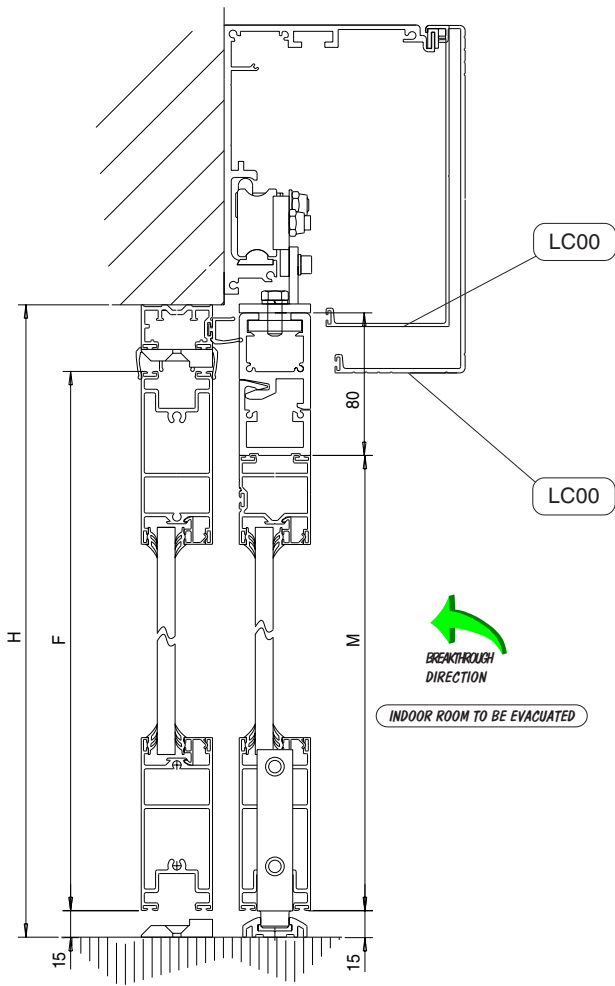

S40 series - sections

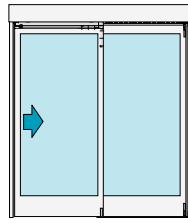

MI6030 / MI6130

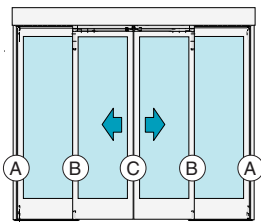
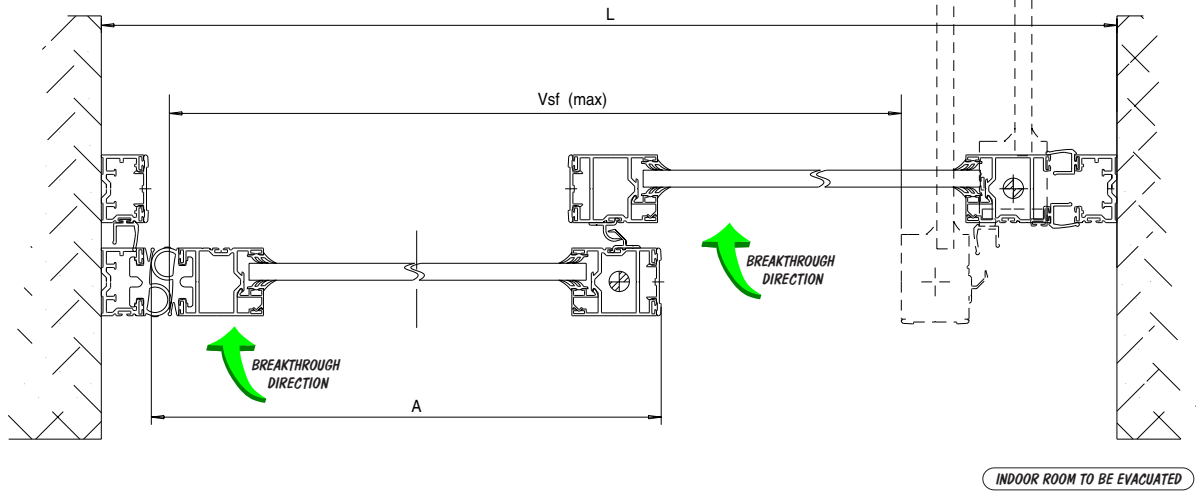

MI6040 / MI6140

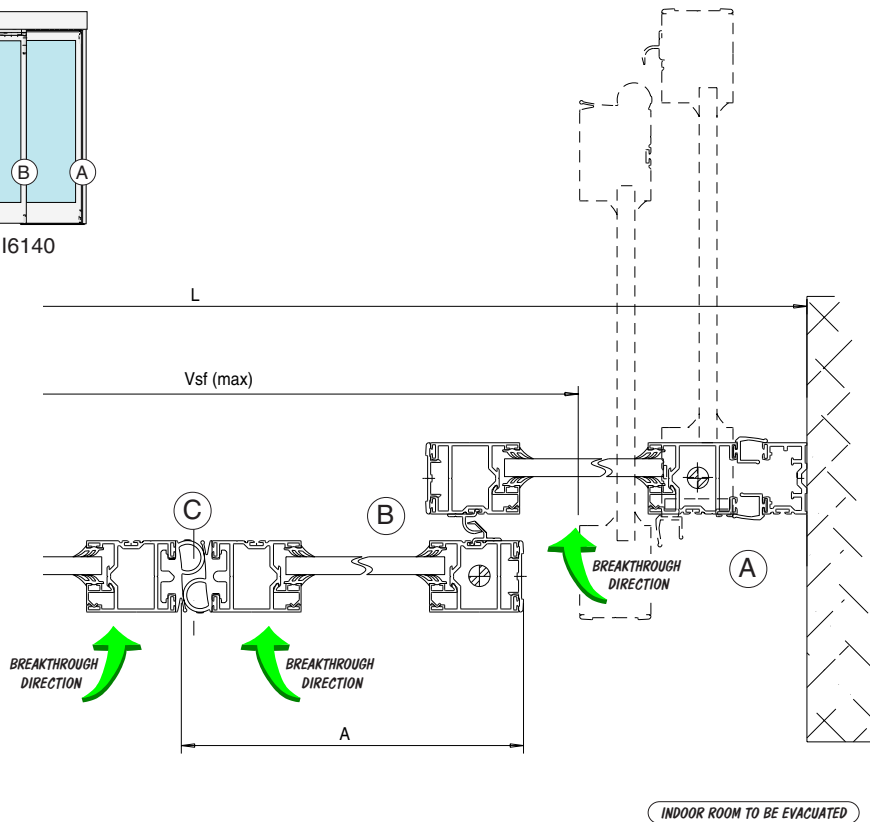

ANTIPANIC BAR machining

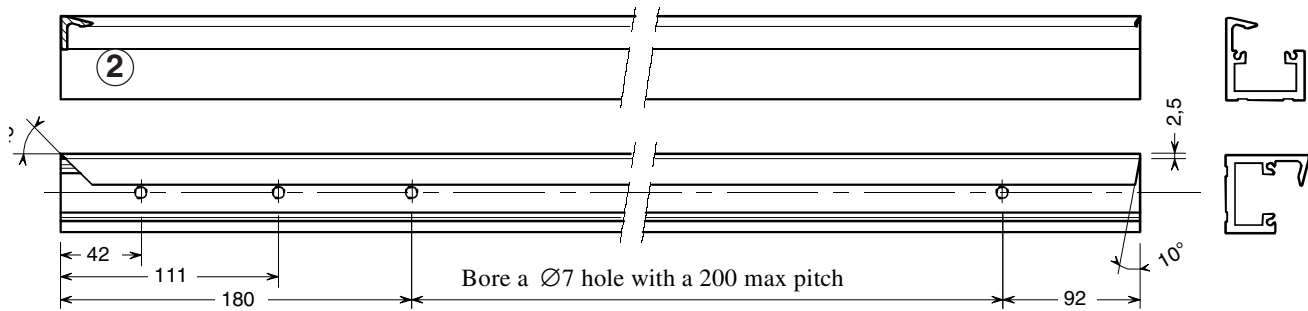
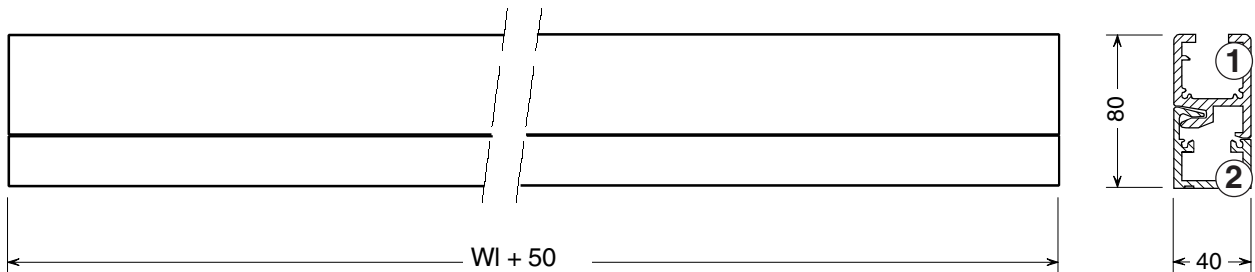
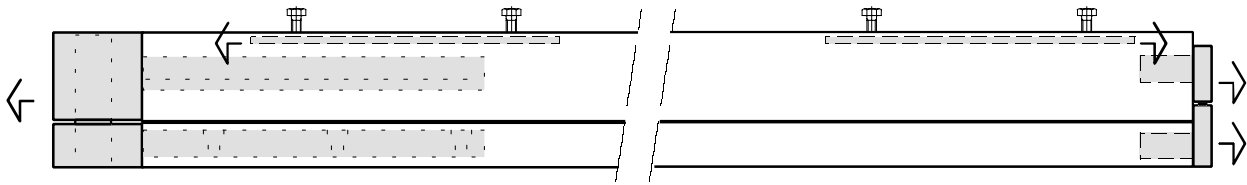

- Take out the PM339A (1) and PM338A (2) upper and lower hooking sections from the package and remove the parts inserted into them.

- Cut them to the proper length using the indicated formula.

- Correctly evaluate the breakthrough side of the doors and work the lower section (2) as in the illustration **.

** The illustration shows the work that must be performed on the **left** door. The **right** door will require mirror-image work.

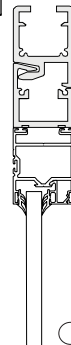
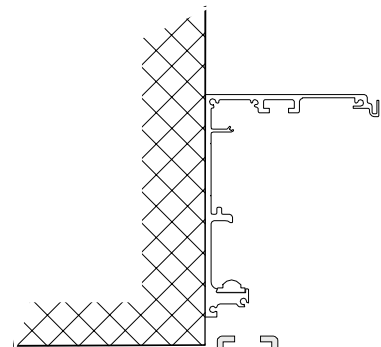

INDOOR ROOM TO BE EVACUATED

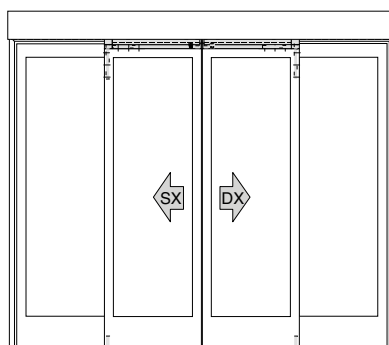

S40 series - ANTIPANIC application on FRAME and FIXED DOORS

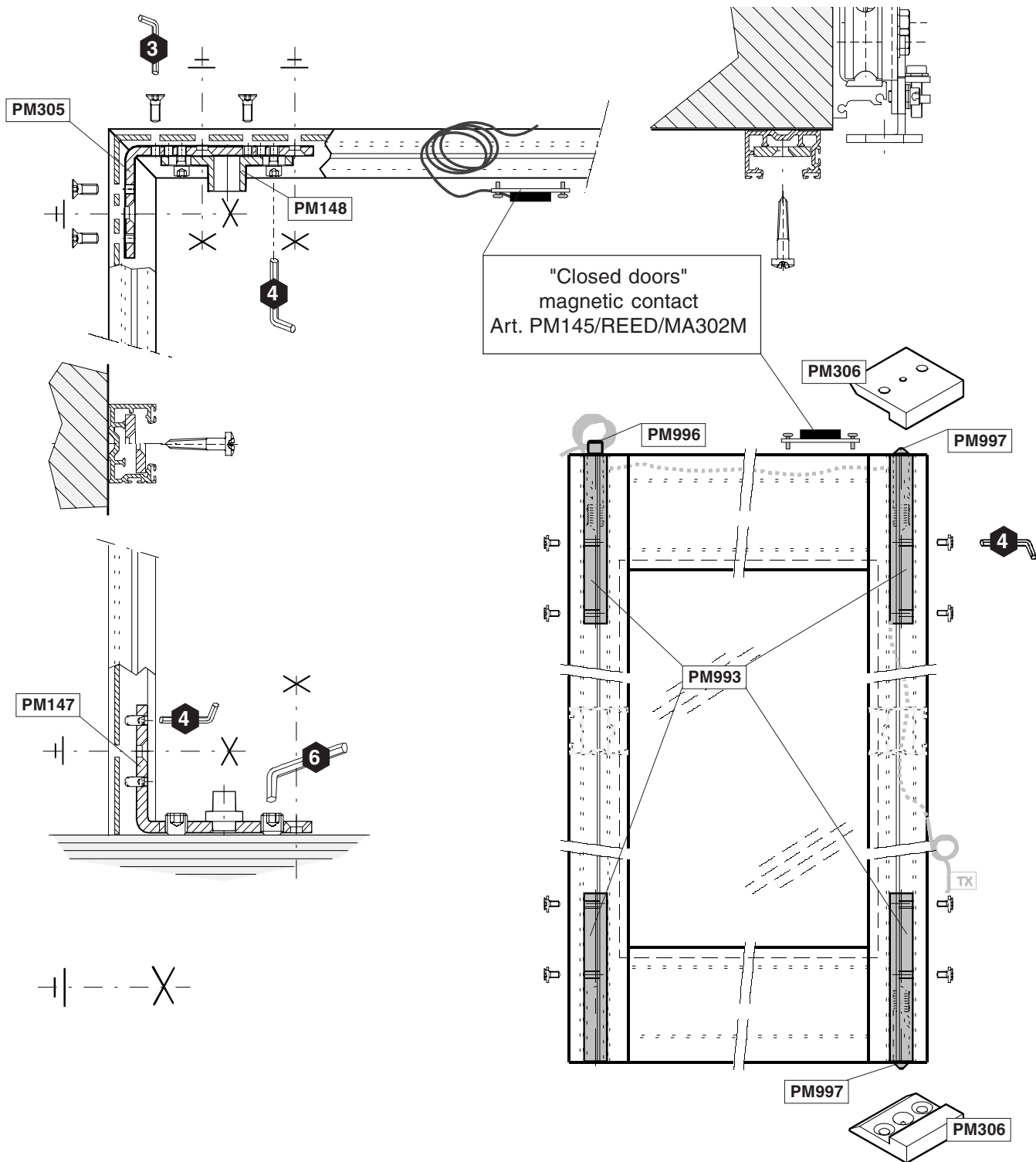

Fixed Frame

- Insert the upper angle elements with the adjustment device (PM305 + PM148) in the frame section and fasten the edge with the flathead screws provided.
- Insert the lower hinge brackets (PM147) in the section and temporarily screw with the M6 socket head screws counter to the frame section (this will allow subsequent door aligning adjustments).
- Fasten the frame to the opening to be covered, starting by fixing the angle elements and lower brackets (bore holes at the points indicated in the illustration with).
- Temporarily insert and align the "closed door" magnetic microswitch (art. PM145 + REED)

Fixed Door

- Insert and fasten hinge parts (art. PM993...) and the magnet (PM145).
- Insert the fixed doors to the wall-type frame, square the doors with the frame and insert the spring latch blocks (PM306), making sure the doors' breakthrough side is correct. Align the microswitch and the magnets and then connect the photoelectric cell cables.
- Verify the correct operation of the latches by moving them a few times.

S40 series - ANTIPANIC BAR application on MOBILE DOORS

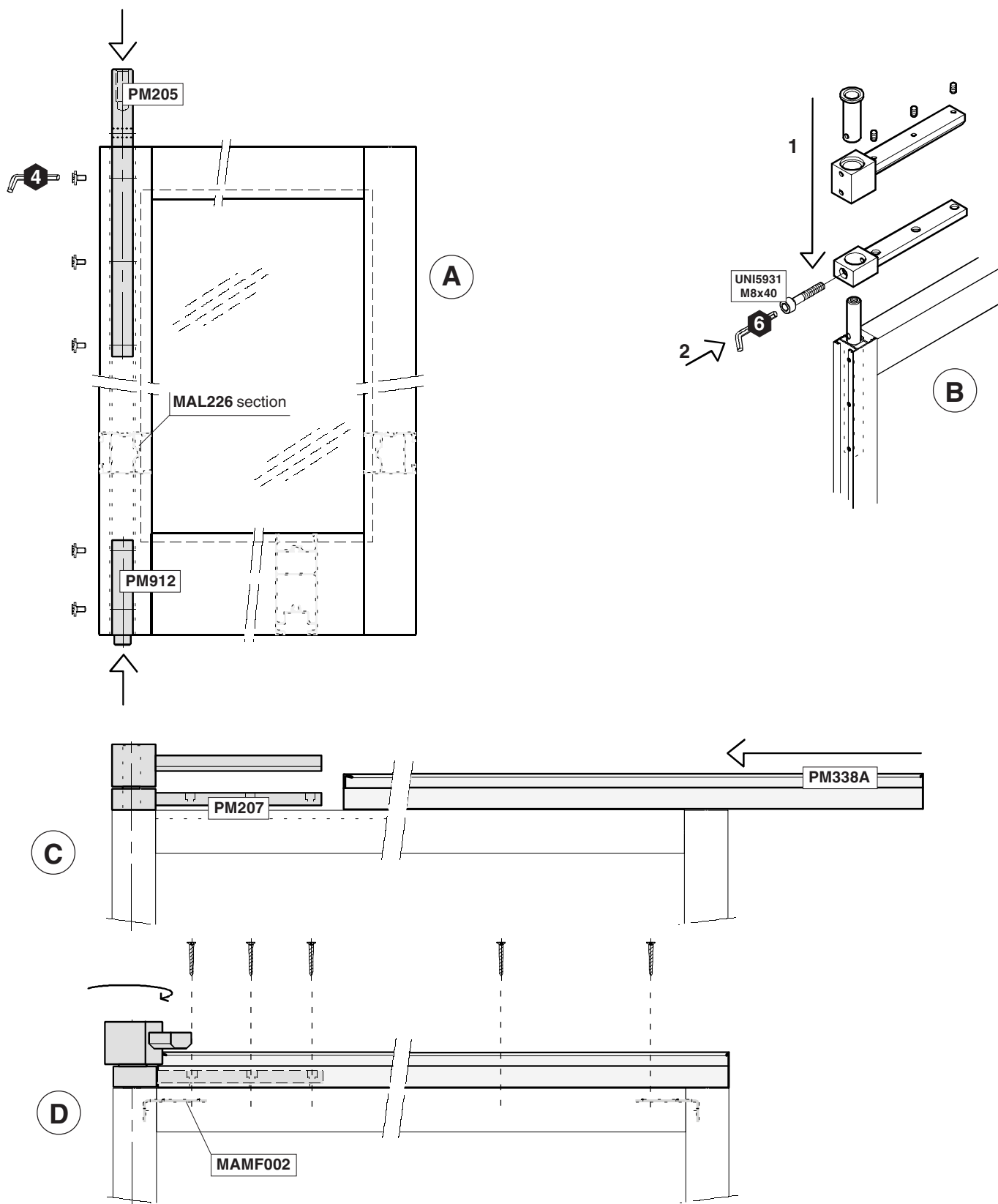

- A** - Insert the PM205 upper pin and PM912 lower pin in the MAL226 back upright section and screw on with screws provided in the holes indicated. Correctly align to the section before screwing on.
- B** - Assemble the joint parts to the jutting pin. Temporarily fasten M8X40 hooking screw.
- C** - Insert the PM338A lower section to the PM207 lower joint, making sure the breakthrough side is facing the right way.
- D** - Match the two elements together (loosen M8X40 screw if necessary), align the door and bore a \varnothing 4.5 hole matching the holes previously bored on the PM338A section and screw with \varnothing 5.5 self-tapping screws. The two edge screws will be screwed onto the MAMF002 edge elements (doorframe fixing squares) to ensure more stability when fastening.

S40 series - ANTIPANIC BAR application on MOBILE DOORS

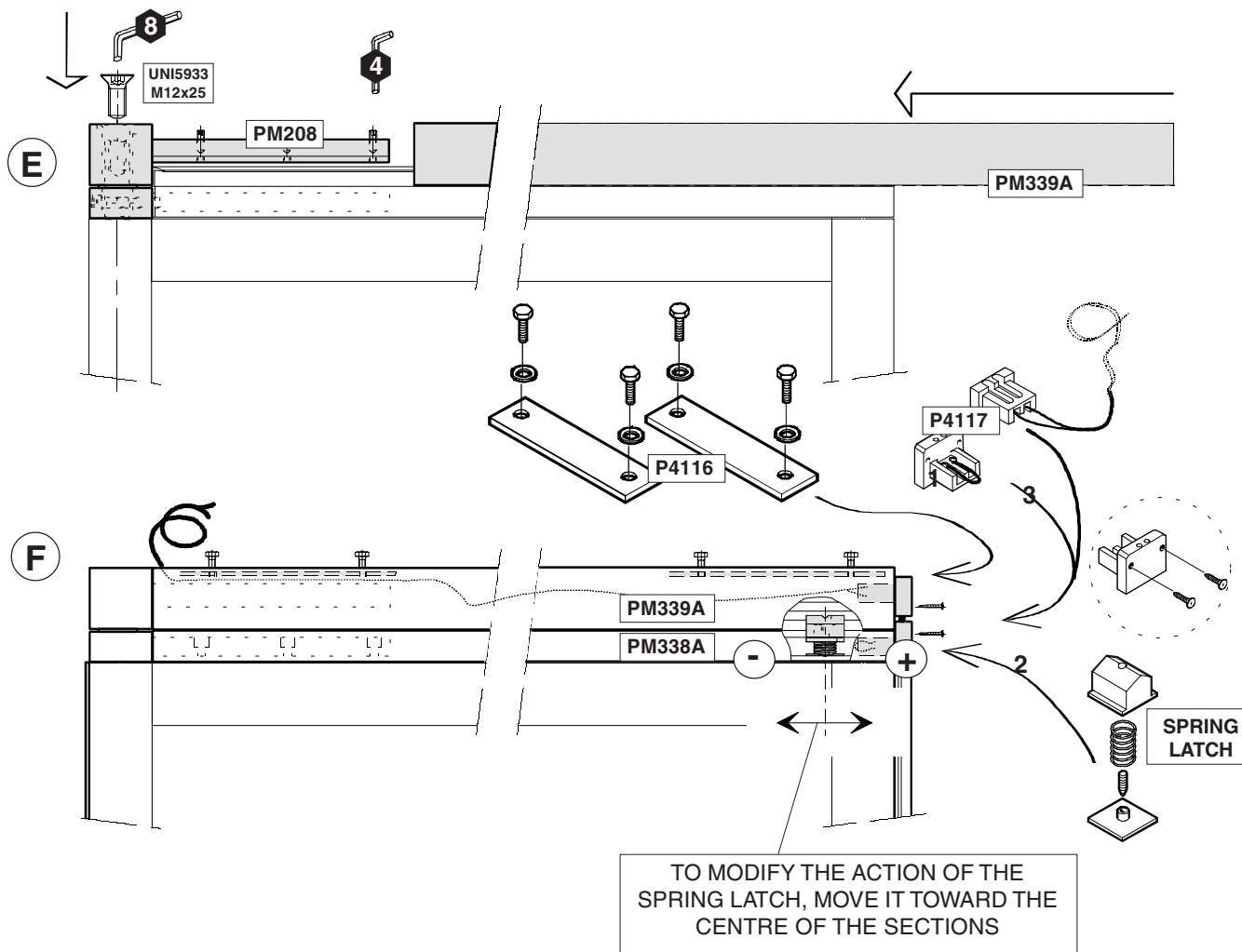

- E -** Screw the M12X25 coupling screw and retighten the hooking screw (if necessary). Insert the PM339A upper section on the PM208 upper joint and screw on the socket head screws provided. Correctly align to the section before screwing.
- F -** Insert the two P4116 hooking plates (to attach to carriages) to the PM339A upper section and insert the closing spring latch to the PM228A lower section, temporarily placing it at 5-8 cm from the edge. Prepare the P4117 contact caps, making a bridge over the lower one and connecting the 2x0.50 bipolar cable to the upper one (for connection to the "closed doors" control circuit). Close the two sections with the two caps and thread the cable through the upper section until it reaches the other end (next to the joint).

** In case of doors with irregular dimensions (see table on page 4), insert the P4117 sliding wheel as indicated on page 18.

SPIRAL CABLE application and MOBILE DOOR mounting

- Apply the PL564 couplings to the beam (two at opposite edges if CORSA1 or RODEO1; one at the centre and two at opposite edges if CORSA2 or RODEO2).
- Insert the coupling in FN930 nylon cable and fasten one end with the C7039 terminal. On the other end, in sequence, attach:
 - a) a PM576 support with the TB57 sliding tube.
 - b) A PM923 spiral cable sized according to sliding length (extension admitted is 20% as opposed to the coiled cable).
 - c) Thread through the central coupling and repeat a) and b) sequences for the second door (only for CORSA2 and RODEO2).
- Then insert the opposite coupling's nylon cable and fasten with the terminal.

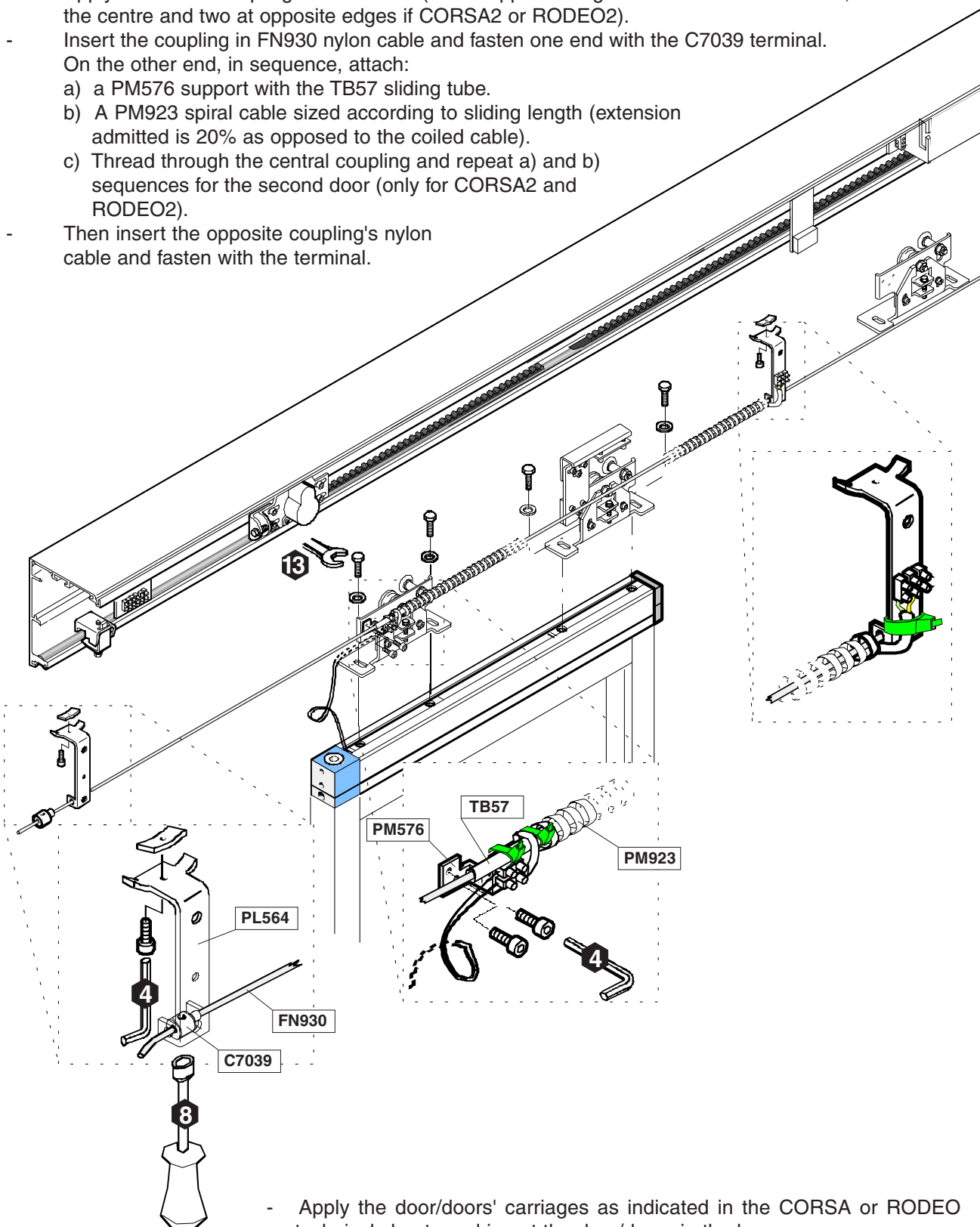

- Apply the door/doors' carriages as indicated in the CORSA or RODEO technical sheets and insert the door/doors in the beam.
- Check the sliding movement and then align and fasten the PM576 connection supports to the appropriate carriages. Verify the correct sizing of the spiral cable, close its ends with the clamps provided and electrically connect the ends as shown in the electric diagram on the next page.
- Similarly, size and connect the 2X0.50 bipolar connection cable to the contact caps previously threaded through the door's structure.
- Lastly, set the PM911A guide to the ground as illustrated on page 17.

