

TECHNICAL SPECIFICATIONS

Technology	: hyperfrequency and microprocessor
Frequency emitted	: 24.125 GHz
Power density emitted	: << 5 mW/cm ²
Mounting height	: 4 m max
Tilt angle	: 0° to 90° vertical : -30° to +30° lateral
Detection area (typical)	
• wide sensing field	: 4 m (W) x 2 m (D)
• narrow sensing field	: 2 m (W) x 2.5 m (D)
Detection mode	: motion
Minimum speed	: 5 cm/s (measured in axis of radar)
Supply voltage	: 12 to 24 V AC ±10% : 12 to 24 V DC +30 %/-10 %
Mains frequency	: 50 to 60 Hz
Power consumption	: < 2 W
Standard output relay (free potential contact)	
• Max contact voltage	: 75 V DC / 50 V AC
• Max contact current	: 1 A (resistive)
• Max switching power	: 30 W (DC) / 60 VA (AC)

Output hold time	: 0.5 s to 9 s (adjustable)
Manual adjustments	
• sensitivity (by push buttons)	
• orientation of sensing field (mechanically)	
• shape of sensing field (choice of antenna)	
Remote control adjustment	
• sensitivity	
• hold time	
• multiple functions	
Temperature range	: from -20°C to +55°C
Immunity	: electromagnetic compatibility (EMC) in accordance with 89/336/EEC
Dimensions	: 120 mm (W) x 80 mm (H) x 50 mm (D)
Weight	: 0.215 kg
Material	: ABS
Colour of housing	: anthracite grey, aluminium finish or white
Length of cable	: 2.5 m

DESCRIPTION OF THE SENSOR

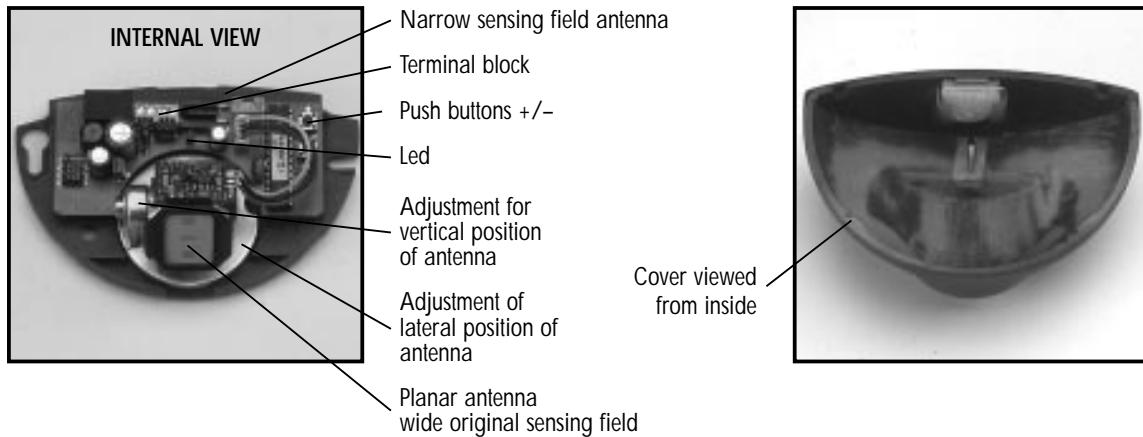

INSTALLATION TIPS



- The sensor must be firmly fastened in order not to vibrate



- The sensor must not be placed directly behind a panel or any kind of material



- The sensor must not have any object likely to move or vibrate in its sensing field



- No fluorescent lighting in the sensing field

OPENING THE SENSOR



• From behind, before installation

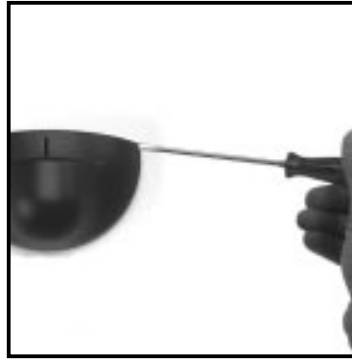

• From the front, after installation

PREPARATION FOR MOUNTING THE SENSOR

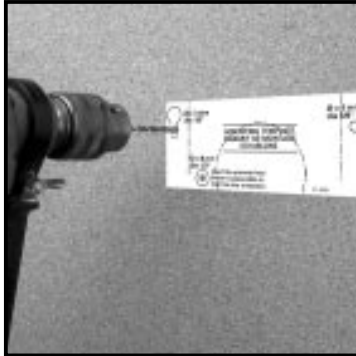

• Paste the template
• Drill as instructed

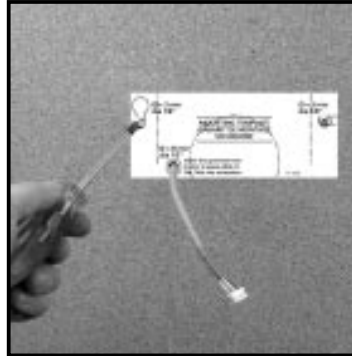

• Insert screws but do not screw them fully home
• If possible, pass the cable where it is supposed to go through

CONNECTING AND MOUNTING THE SENSOR



• Run the cable through the orifice designed for this purpose

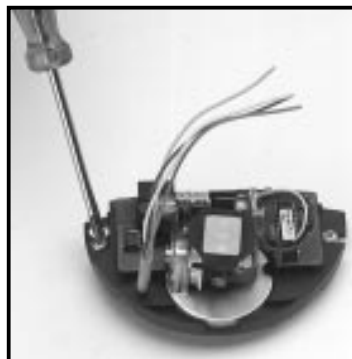

• Position the sensor and tighten the two screws. Make sure you leave enough cable to reach the terminal block



① 12-24V ac/dc ② COM ③ NO ④ NC ⑤

OTHER MOUNTING OPTIONS

1. This device may be fixed on the ceiling, so long as the spherical part of the sensor is facing in the opposite direction to the door, and so long as an angular position of around 60° is chosen for the antenna.

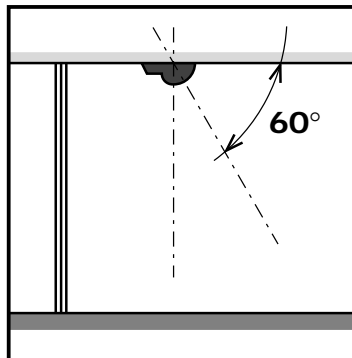

SETTING THE SENSING FIELD DIMENSIONS

A. THE WIDTH OF THE SENSING FIELD IS DETERMINED BY THE CHOICE OF THE PLANAR ANTENNA

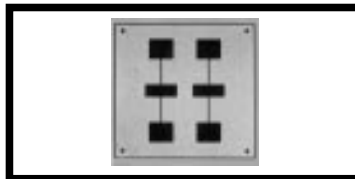
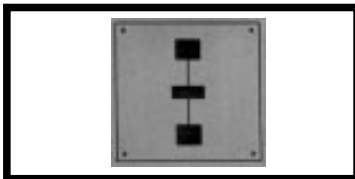

• To obtain a **wide sensing field** : use the **3-elements** antenna

• To obtain a **narrow sensing field** : use the **6-elements** antenna

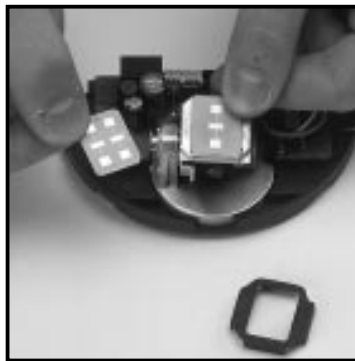
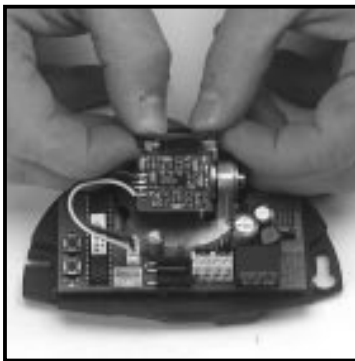

• Carefully remove the protective cover of the antenna

• Change the antenna and replace the protective cover

SENSING FIELDS ACCORDING TO THE TYPE OF ANTENNA TYPE

The sensing fields here on the right correspond to the following adjustments :

- vertical angle of antenna : 30°
- sensitivity : 9

Mounting height : 2.2 m

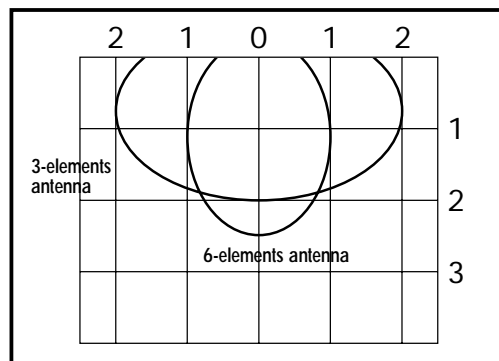

B. THE POSITION OF THE SENSING FIELD IS DETERMINED BY THE VERTICAL TILT ANGLE OF THE ANTENNA

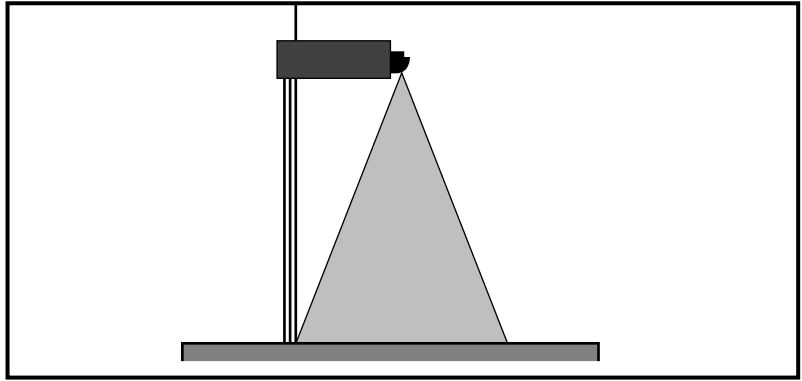
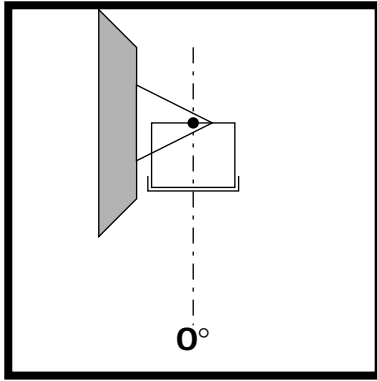

• To obtain a sensing field **as close to the door as possible** :
the tilt angle of the antenna must be set at the **minimum** position (0°)

- Example of use with a very deep operator

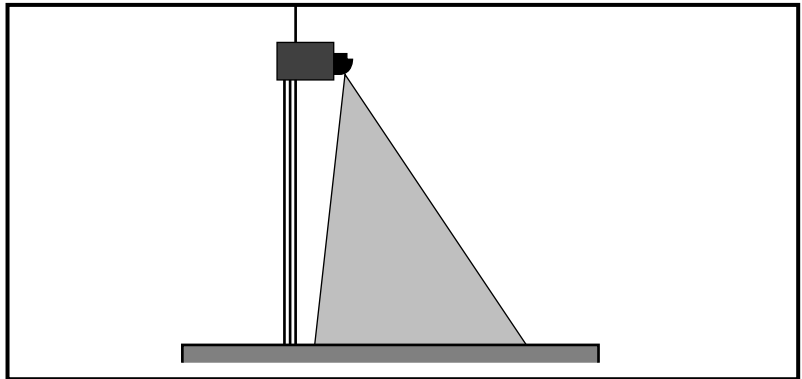
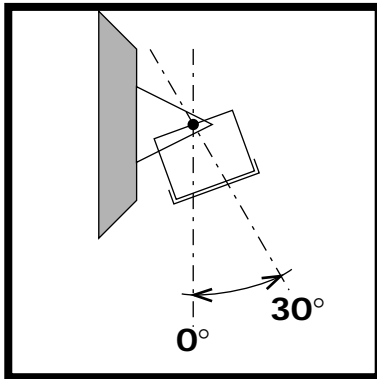

• To obtain a sensing field **close to the door** :
the tilt angle of the antenna must be set at the position 30°

- Example of use with a normal operator

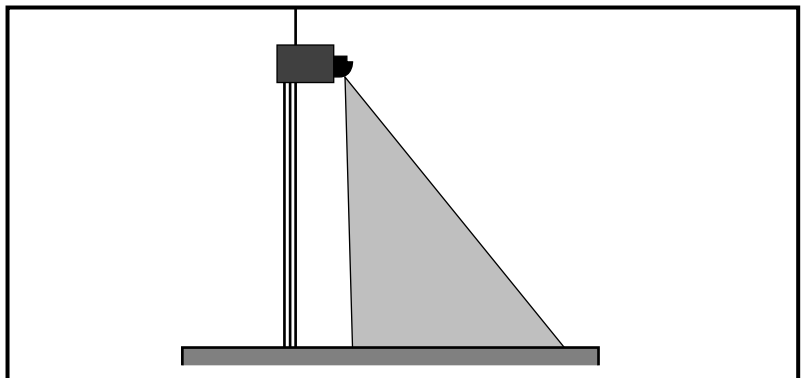
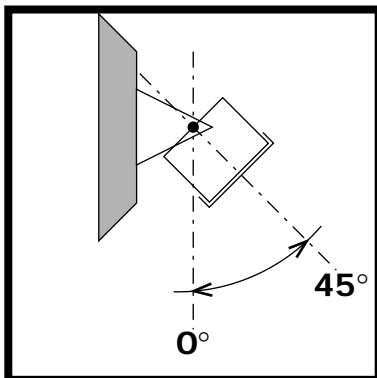

• To obtain a sensing field **far from the door** :
the tilt angle of the antenna must be set at the maximum position (45°)

- Example of use with a normal operator

DETECTION SENSING FIELD ACCORDING TO THE VERTICAL TILT ANGLE OF THE ANTENNA

The sensing fields here on the right correspond to the following adjustments :

- vertical angle of antenna : 0° , 20° , 45°
- sensitivity : 9

Mounting height : 2.2 m

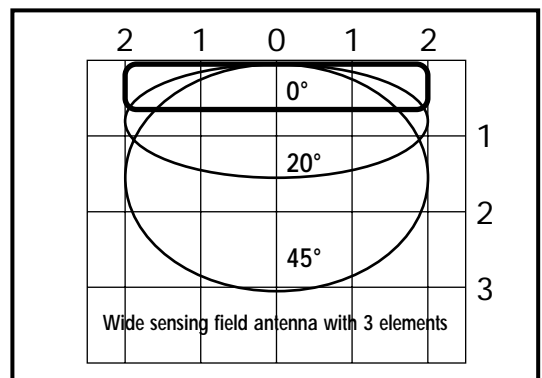

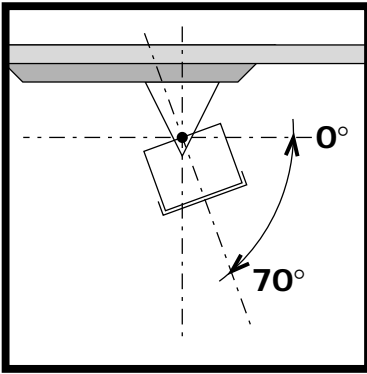

DETECTION SENSING FIELDS FOR A CEILING MOUNTING

The sensing fields here on the right correspond to the following adjustments :

- vertical angle of antenna : 70°
- sensitivity : 9

Mounting height : 2.2 m

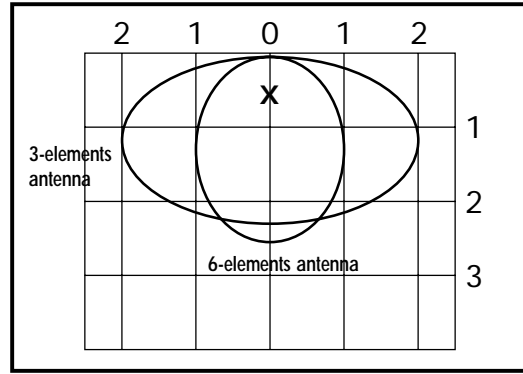

- For ceiling mounting, the vertical tilt angle of the antenna must be set at the maximum position of $70-75^\circ$ and the spherical part of the sensor must be oriented in the opposite direction to the door

C. THE LATERAL POSITION OF THE SENSING FIELD IN FRONT OF THE DOOR IS DETERMINED BY THE LATERAL TILT ANGLE OF THE ANTENNA

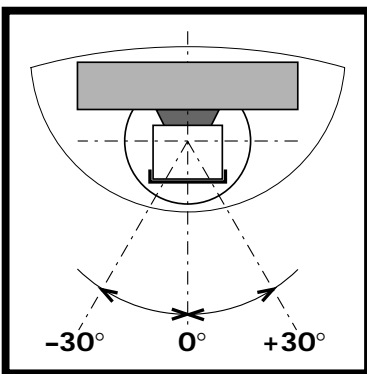

The sensing fields here on the right correspond to the following adjustments :

- wide sensing field antenna
- lateral angle of antenna : $30^\circ, -30^\circ$
- sensitivity : 1, 6, 9

Mounting height : 2.2 m

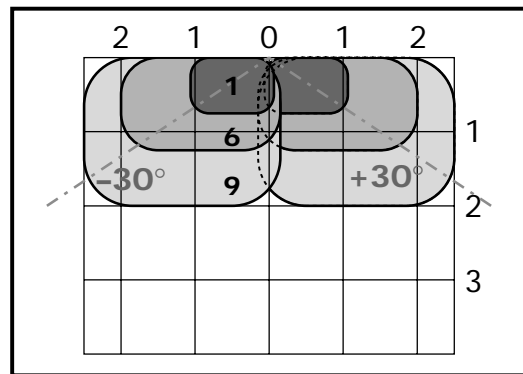

D. THE DIMENSIONS (WIDTH, DEPTH, DEAD ZONE) OF THE SENSING FIELD DEPEND ON THE SENSITIVITY SETTING : SET BETWEEN 0 AND 9

The sensing fields here on the right correspond to the following adjustments :

- wide sensing field antenna
- vertical angle of antenna : 30°

Mounting height : 2.2 m

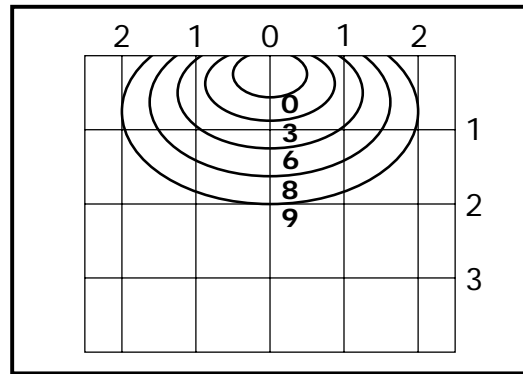

E. THE DIMENSIONS (WIDTH, DEPTH, DEAD ZONE) OF THE SENSING FIELD DEPEND ON THE MOUNTING HEIGHT

The sensing fields here on the right correspond to the following adjustments :

- wide sensing field antenna
- vertical angle of antenna : 20°
- sensitivity : 9

Mounting height : 3 m

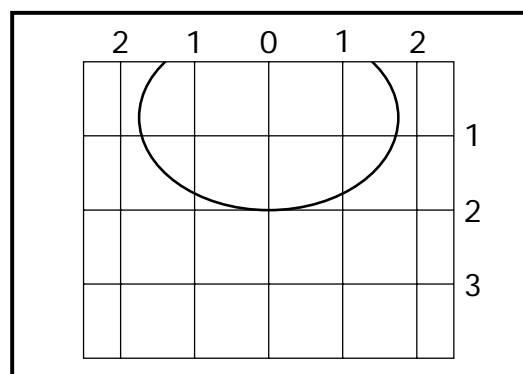

**MANUAL
CONFIGURATION
OF
THE SENSOR**

If you do not have a remote control, you can adjust the sensitivity parameter only, by means of the push buttons + and -.

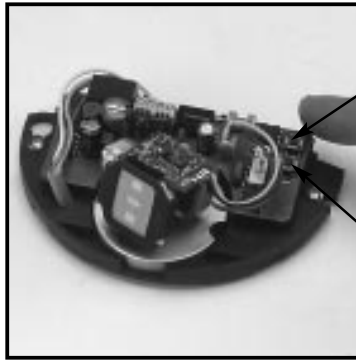

+ : press to increase sensitivity by one unit

- : press to decrease sensitivity by one unit

All the sensor parameters not accessible manually are set at the factory values. These default values may be restored by pressing the two push buttons together for at least two seconds, which resets everything, including the access code.

**LED
SIGNAL**



The LED flashes for a few seconds when the unit is started up, and flashes continuously during configuration. The LED then lights up when the sensor detects motion.

TROUBLESHOOTING

SYMPTOM	PROBABLE CAUSE	CORRECT ACTION
The door will not open The LED does not light up	The sensor power is off	a. Check the supply b. Check the supply voltage
The sensor does not respond to the remote control	The batteries have been inserted incorrectly	Check battery insertion
The sensor does not respond to the code entered with the remote control	The access code has been changed	Remove the cover and press the 2 buttons simultaneously for at least two seconds. Then press the unlock button to begin the configuration process again.
The door opens and closes constantly	The sensor «sees» the motion of the door	a. Increase the tilt angle of the antenna b. Reduce the sensitivity

1. INSERTION OF BATTERIES



remote control **OPTIONAL!**
article code: **MRT001**

- Open the battery compartment
- Insert two AAA batteries as shown above
- Close the battery compartment





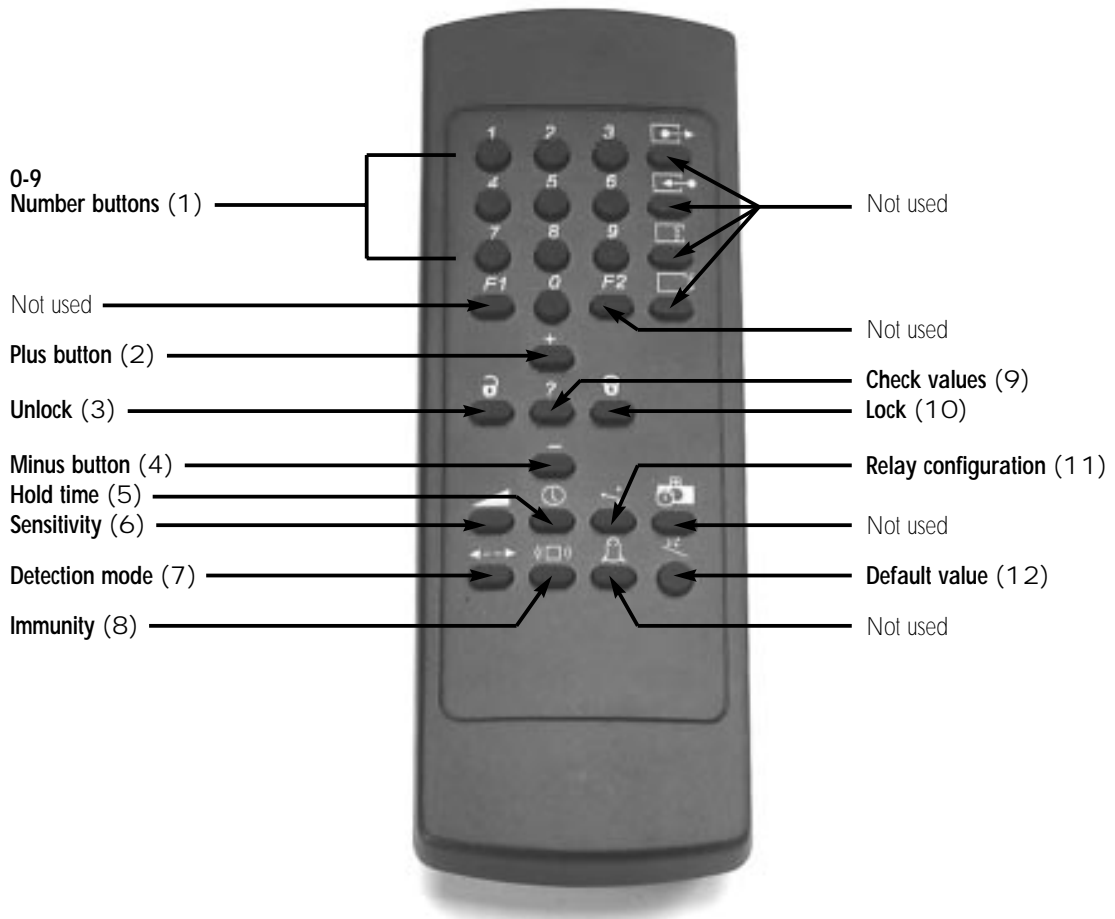

2. REMOTE CONTROL OPERATION

For optimum results, point the remote control directly at the sensor before you press the buttons. It has a range of about 5 metres. The sensor can be adjusted with or without its cover.



3. CONFIGURING YOUR SENSOR

Every adjustment session using the infrared remote control must start with unlocking and end in locking. (The table below lists the parameters able to be adjusted by remote control and the operations required in order to adjust these parameters).

PARAMETER	USER ACTIONS	FACTORY SETTING	LED STATUS
Unlock 	Press UNLOCK button (3) Then type in your four-figure pin number using NUMBER buttons 0-9 (1). The first time you adjust your sensor*, enter the factory value code (0000).	0000	The LED flashes slowly to indicate that an adjustment session is under way.
Sensitivity 	Press the SENSIVITY button (6). Use NUMBER buttons 0-9 (1) to enter the sensitivity coefficient you want or adjust this coefficient using the PLUS (2) or MINUS (4) buttons. Repeat this operation to change the sensitivity again.	7	The LED flashes more rapidly while the unit waits for the corresponding numerical value. It then continues to flash more slowly.
Hold time 	Press the HOLD TIME button (5) and use NUMBER buttons 0-9 (1) to enter the required hold time (up to 9 seconds).	0,5 seconds	The LED flashes more rapidly while the unit waits for the corresponding numerical value. It then continues to flash more slowly.
Detection mode <i>only for MR8106</i> 	Press the DETECTION MODE button (7). Use NUMBER buttons 1-3 (1) to select the required mode : button 1 : bidirectional mode 2 : unidirectional mode 3 : unidirectional mode with MTF function	unidirectional for MR8106 with MTF function	The LED flashes more rapidly while the unit waits for the corresponding numerical value. It then continues to flash more slowly.
Relay configuration 	Press the RELAY CONFIGURATION button (11) and use NUMBER buttons 1-4 (1) to select the required relay configuration : button 1 : active output, relay contact closed during detection, open during non-detection 2 : passive output, relay contact open during detection, closed during non-detection 3 : continuous detection, relay contact always closed 4 : continuous non-detection, relay contact always open	active output	The LED flashes more rapidly while the unit waits for the corresponding numerical value. It then continues to flash more slowly.
Immunity 	Press the IMMUNITY button (8). Use NUMBER buttons 1-3 (1) to select the type of digital filter required : button 1 : detection of quasi-presence 2 : norma 3 : increased immunity	Normal	The LED flashes more rapidly while the unit waits for the corresponding numerical value. It then continues to flash more slowly.
Lock 	When all the parameters have been recorded, press the LOCK button (10). If you wish to enter a new access code, use NUMBER keys 0-9 to enter the new four-figure code within 10 seconds. It must begin with 1. If you want to keep the current access code, press a second time the LOCK button (10).	0000	The LED stops flashing to return to its normal function.

When the remote-controlled configuration of the sensor is complete, you can find out the values entered for the parameters at any time in the following way :

PARAMETERS	USER ACTIONS
Check values 	Press the button for the parameter whose value you wish to check (button 5, 6, 7, 8, 11), then press the CHECK VALUES button (9). Then simply count the number of times the LED flashes. This corresponds to the status of the parameter in question. Repeat the operation to find out the status of the other parameters. eg : <ul style="list-style-type: none"> • <u>detection mode button - 2 flashes</u> the parameter is set in unidirectional mode • <u>sensitivity button - 6 flashes</u> the parameter is set at 6

When the remote-controlled configuration of the sensor is complete, you can reset all the parameters to their factory values by means of the following procedure :

PARAMETERS	USER ACTIONS
Default 	Press the DEFAULT VALUE button (12), then press the number button 1. All the parameters are reset to their factory values. In case of high mounting, the sensor can be configured in order to be more sensitive : before adjusting the sensor , press the DEFAULT VALUE button (12). Then press the number button 2. All the parameters are reset to their factory values but the sensor has now an increased sensitivity scale. Then adjust the other parameters. Should you come back to the standard sensitivity scale, repeat the procedure with the DEFAULT VALUE button followed by 1.

* **Note : when your access code is reset to the factory value (0000) you can access adjustment mode directly without the need to re-enter this code.**