

The CAME digital inductive loop detector range is the ideal solution for parking barrier control, motorized gates and doors, vehicle access control and industrial control systems.

SMA
Single loop detector
with 12 to 24V ac/dc power supply

SMA2
Dual loop detector
with 12 to 24V ac/dc power supply

SMA230
Single loop detector
with 230V ac power supply

TECHNICAL SPECIFICATIONS

Technology	inductive loop
Tuning	automatic
Detection mode	presence
Presence time	1 min to infinity (permanent presence) with 250 steps
Pulse time output	100 ms or 500 ms
Inductance range	20 μ H to 1000 μ H
Frequency range	20 kHz to 130 kHz
Frequency steps	4 for single loop 2 for dual loop (for each loop)
Sensitivity (ΔL/L)	0.005% to 0.5% with 250 steps
Reaction time	25 ms for single loop 50 ms for dual loop (each channel)
Setup time at power on	8 s max by channel
Power supply (depending on model)	12-24 AC/DC \pm 10% 230 V AC \pm 10%
Mains Frequency	48 to 62 Hz
Power Consumption	< 2.5 W
Storage temperature range	-30°C to +70°C

Operating temperature range	-30°C to +40°C
Degree of protection	IP40
2 Output relays (free potential change-over contact)	<ul style="list-style-type: none"> max contact voltage : 230 VAC max contact current : 5A (resistive)
LED indicators	<ul style="list-style-type: none"> 1 green LED : power 1 red LED : Loop status 1 1 red LED : Loop status 2
Protections	<ul style="list-style-type: none"> loop insulation transformer zener diodes gas discharge clamping
Connection	standard 11-pin round connector 86CP11
Dimensions	77mm (H) x 40mm (W) x 75mm (D)
Weight	< 200gr
Product compliance	R&TTE 1999/5/EC EMC 89/336/EEC UL listed equipment for UL 508

DESCRIPTION OF THE SENSOR

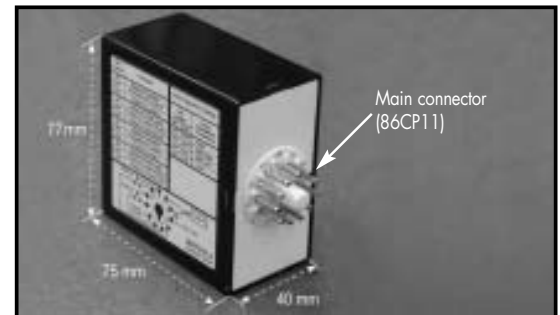
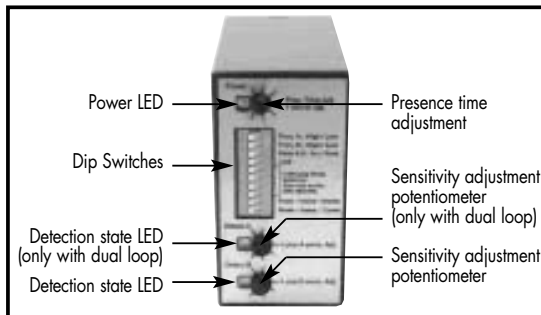

LOOPS INSTALLATION TIPS

A. CABLE SPECIFICATIONS FOR LOOP AND FEEDER

- 1.5mm² cross section area
- Multi-strand cable
- Insulation material : PVC or Silicone
- For the feeder cable, the wire must be twisted at least 15 times by meter
- Feeder for long runs used for foil screened cable is recommended (earth at equipment end only)
- The feeder cable must be firmly fixed to avoid any false detection (max length : 100 m)
- Waterproof cable junction box is required

B. LOOP GEOMETRY

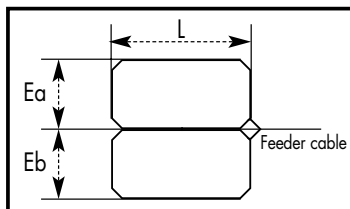

- With two adjacent loops connected to a dual channel sensor, it is possible for these loops to share a common slot, if so required. As the channels are multiplexed, no interference will occur
- Avoid large loops or long feeder (max 100 m), the sensitivity will be affected

C. DETERMINATION OF THE NUMBER OF LOOP TURNS

WARNING :

For conformity reasons, in any situation, the antenna factor defined as the loop surface multiplied by the number of turns should not exceed $NA = 20$

For example, if $L=2m$, $Ea=1m$ and the number of turns=4, then the $NA = 2 \times 1 \times 4 = 8 < 20$.

Find hereafter the recommended values for the turns :

Area	Number of turns
< 3 m ²	4
3 - 5 m ²	3
6 - 10 m ²	2

D. SLOT DEPTH

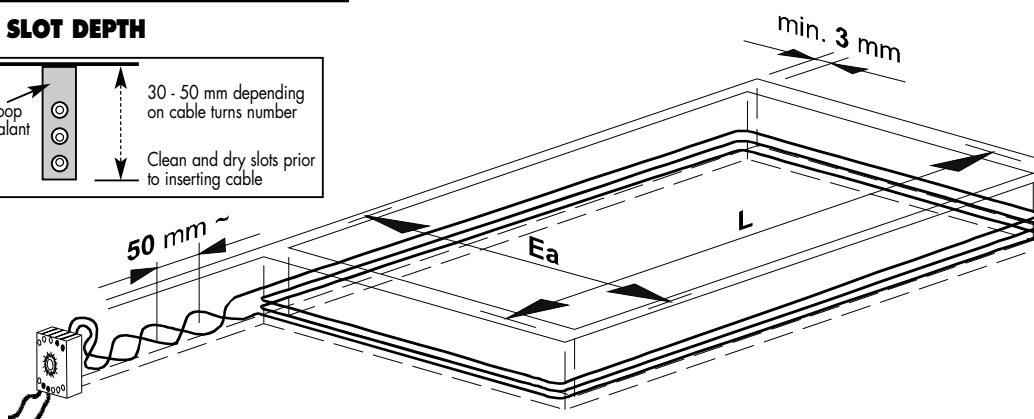
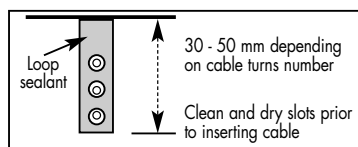

WIRING

WARNING :

Do not remove the grease on the connector's pins

UL REQUIREMENT : The unit has to be mounted on a suitable UL recognized SWIV2 Relay Socket

Relay socket suggested references :

- OMRON PF113A-D
- LUNDBERG R11
- MAGNECRAFT 70-465-1
- IDEC SR3P-05C
- ERSCE ES11
- CUSTOM CONNECTOR CORPORATION OT11



- Pin 1** : Power supply
- Pin 2** : Power Supply
- Pin 3** : Relay 2 (NO)
- Pin 4** : Relay 2 (COM)
- Pin 5** : Relay 1 (NO)
- Pin 6** : Relay 1 (COM)
- Pin 7** : Loop A
- Pin 8** : Loop common and earth
- Pin 9** : Loop B
- Pin 10** : Relay 1 (NC)
- Pin 11** : Relay 2 (NC)

ADJUSTMENTS

A. THE 3 CONFIGURATIONS

- Configuration # 1 : single loop detector (SMA/SMA230)
- Configuration # 2 : dual loop detector in independent mode (SMA2 with dip-switch # 10 OFF)
- Configuration # 3 : dual loop detector in combined mode (SMA2 with dip-switch # 10 ON)

B. POTENTIOMETERS

PRESENCE TIME

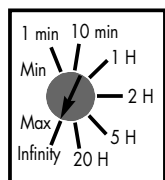

SENSITIVITY

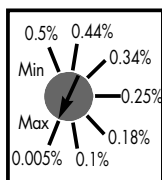

- A potentiometer for adjustment of the maximum duration of a presence detection : from 1 min to infinity
- A potentiometer for adjustment of the linear sensitivity (Δf) for the loop A : from 0.005% to 0.5 %
- A potentiometer for adjustment of the linear sensitivity (Δf) for the loop B : from 0.005% to 0.5 %

C. RELAY CONFIGURATIONS (Dip Switch #3)

The loop A activates the relay A and the loop B activates the relay B. With the dual loops in combined mode the relay A provides the presence detection and the relay B provides the movement direction

	ACTIVE MODE (dip switch #3 OFF)	PASSIVE MODE (dip switch #3 ON)
Detection	COM — NO • NC	COM — NO • NC
No Detection	COM — NO • NC	COM — NO • NC

D. DIP SWITCHES

After each dip switch change the sensor launches a learning process

Dip Switch #1	Frequency Adjustments of Loop A
Dip Switch #2	Frequency Adjustments of Loop A (with single loop) or Loop B (with dual loops)
Dip Switch #3	Relay configuration : active or passive.
Dip Switch #4	Automatic Sensitivity Boost (ASB option) [recommended for better trucks detection] : During a detection the sensitivity increases automatically to 8 times the preset sensitivity given by the sensitivity potentiometer adjustment. It is limited to the maximum sensitivity ($\Delta f = 0.005\%$). It goes back to the preset value after detection stops.
Dip Switch #5	Relay A function : presence or pulse (not used with dual loop in combined mode)
Dip Switch #6	Relay A Pulse type : entry or exit (used only at pulse function) or Relay B mode (with dual loop in combined mode) (see next drawing) <ul style="list-style-type: none"> • non-directional : The relay B provides a pulse according to the dip switches #7 and #8 setting. • directional A → B : The relay B provides a pulse only if the loop A is detecting before the Loop B. The detection takes place according to dip switches #7 and #8 logic. <div style="border: 1px solid black; padding: 5px; margin-top: 10px;"> <p>Warning : During the detection, the 2 loops have to detect simultaneously for a short period to be able to determine the movement direction. During loop installation make sure the 2 loops are close enough to each other to ensure a common detection (typical 1m).</p> </div>
Dip Switch #7	Relay B function : presence or pulse or loop selection for relay B pulse : pulse on Loop B or pulse on Loop A (used with dual loop in combined mode)
Dip Switch #8	Relay B Pulse type : entry or exit (used only at pulse function)
Dip Switch #9	Pulse duration for both relays (used only at pulse function): 100 ms or 500 ms
Dip Switch #10	Dual loop mode : independent or combined A → B (not used with single loop)

	SMA230 Configuration #1 Single loop		SMA2 Configuration #2 Dual loop in independent mode		SMA2 Configuration #3 Dual loop in combined mode	
	OFF	ON	OFF	ON	OFF	ON
DS#1	See next table		High (loop A)	Low (loop A) [High -30%]	High (loop A)	Low (loop A) [High -30%]
DS#2			High (loop B)	Low (loop B) [High -30%]	High (loop B)	Low (loop B) [High -30%]
DS#3	Active mode	Passive mode	Active mode	Passive mode	Active mode	Passive mode
DS#4	ASB OFF	ASB ON	ASB OFF	ASB ON	ASB OFF	ASB ON
DS#5	Relay A : Presence on loop A	Relay A : Pulse on loop A	Relay A : Presence on loop A	Relay A : Pulse on loop A	Not used	Not used
DS#6	Relay A : Pulse on loop A entry	Relay A : Pulse on loop A exit	Relay A : Pulse on loop A entry	Relay A : Pulse on loop A exit	Relay B : non-directional mode	Relay B : directional A → B mode
DS#7	Relay B : Presence on loop A	Relay B : Pulse on loop A	Relay B : Presence on loop B	Relay B : Pulse on loop B	Relay B : Pulse on loop B	Relay B : Pulse on loop A
DS#8	Relay B : Pulse on loop A entry	Relay B : Pulse on loop A exit	Relay B : Pulse on loop B entry	Relay B : Pulse on loop B exit	Relay B : Pulse on loop entry	Relay B : Pulse on loop exit
DS#9	100 ms	500 ms	100 ms	500 ms	100 ms	500 ms
DS#10	Not used	Not used	Independent mode	Combined mode	Independent mode	Combined mode

Frequency adjustment for loop A for single loop detector		
Dip Switch #1	Dip Switch #2	Loop frequency
OFF	OFF	High
ON	OFF	Mid High [High -20%]
OFF	ON	Mid Low [High - 25%]
ON	ON	Low [High - 30%]

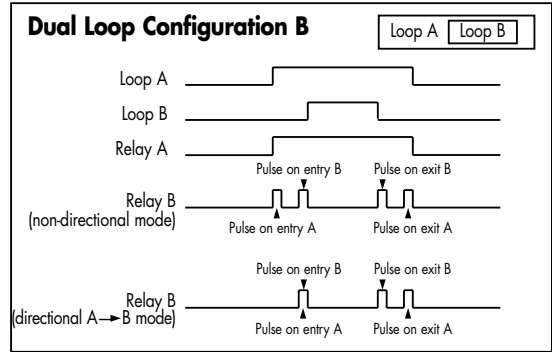
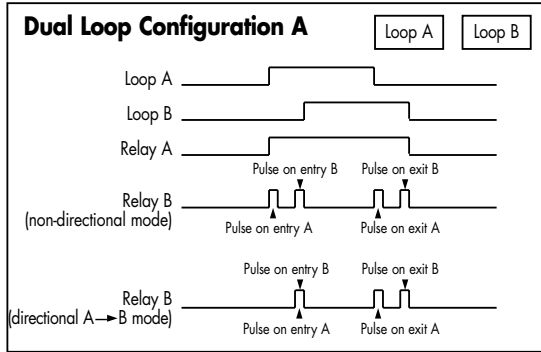

LED SIGNAL

- 1 Green LED shows when the module is powered
- 2 Red LEDs give
 - the corresponding loop detection state in normal situation
 - the value of the oscillation frequency measurement or an error message on power ON

In normal situation the red LED stays ON as long as the loop detects any metallic object.

On power ON the sensor measures the oscillation frequency of each loop. The result of this measurement is displayed using the corresponding red LED. The amount of blinking indicates the tens value of the frequency. For example 4 short flashes correspond to a frequency between 40 kHz and 49 kHz. After this message the LED goes back to normal display. If the loop oscillation frequency falls outside the limits set between 20 kHz and 130 kHz the red LED displays an error message and the sensor activates the corresponding relay. The blinking frequency shows the type of error according to the next table. The sensor will stay in this state until the problem is cleared and the frequency goes to the right range.

Remark : The sensor launches automatically a learning process if the oscillation frequency changes more than 10% in comparison with the measurement value.

Loop frequency error	LED display
Oscillation frequency too LOW or loop open	LED blinking at 1Hz
Oscillation frequency too HIGH	LED blinking faster at 2 Hz
Loop shorted or no oscillation	LED blinking slower at 0.5 Hz

TROUBLE-SHOOTINGS

SYMPTOM	PROBABLE CAUSE	CORRECT ACTION
The loop detector will not work The green LED is off	There is no power supply to the loop detector	Check power supply
The loop detector will not work The red LED is flashing slowly (0.5 Hz)	The corresponding loop is shorted	Check the loop cable
The loop detector will not work The red LED blinks at either 1Hz or 2Hz	The frequency of oscillation falls outside the allowed range	Adjust frequency with dip switches or change loop turns
The loop LED is detecting properly but the contact is not made	Bad connection of the relay contacts	Check relay connections
Dip switches 5 to 8 are not responding properly	Their function varies according to dip switch #10 setting	Check the appropriate loop mode required and adjust dip switch #10